



## **TECHNICAL MANUAL**

### **AIR TO WATER HEAT PUMP**

**INDOOR UNIT  
(SPLIT BOX)  
HSB60-W**

**(TANK UNIT)  
PT300**

**(CONTROLLER)  
RC-HY20-W  
RC-HY40-W**

**OUTDOOR UNIT  
FDCW60VNX-W**



## Table of Contents



















<b>Safety precautions</b>	2	<b>Service</b>	121
<b>Technical data</b>	5	<b>Operation control function by the indoor unit control</b>	122
<b>Technical specifications</b>	6	<b>Operation control function by the outdoor unit control</b>	130
Specifications	6	<b>Alarm list</b>	141
Installation requirement	13	Alarm with automatic reset	141
Operating temperature range	14	Outdoor unit alarm	144
Capacity diagram	16	<b>Troubleshooting guide</b>	146
<b>Dimensions</b>	18	220 - High pressure alarm	146
Indoor units	18	228 - Failed defrost operation	147
Outdoor unit	20	294 - Incompatible heat pump	148
Controller	21	404 - S. fault HP	149
<b>Electrical circuit diagram</b>	22	403,412,415-Sensor fault from PCA154	150
Indoor unit	22	E35 - High HX temp	151
Outdoor unit	23	E36 - Hot gas alarm	152
Controller	24	E37 - S. fault Tho-R	153
<b>Installation</b>	34	E38 - S. fault Tho-A	154
<b>Outdoor unit installation</b>	35	E39 - S. fault Tho-D	155
FDCW60VNX-W	35	E40 - High pressure alarm	156
<b>Indoor unit installation</b>	41	E42 - Current cut	157
General information for installer	41	E47 - Inverter A/F module over current	158
Pipe installation	47	E48 - Fan alarm	159
Electrical installation	54	E51 - Inverter and fan motor error	160
Commissioning and adjusting	70	E59 - Inverter error	161
<b>Control</b>	83	E60 - Rotor lock	162
<b>Control</b>	84	<b>Component replacement</b>	166
Display unit	84	Indoor units	166
Menu system	85	Outdoor unit	172
Menu list	88	FDCW60VNX-W	173
Menu 1- Indoor climate	88	<b>Components</b>	178
Menu 2- Hot water	88	<b>Outdoor unit</b>	179
Menu 3- Info	88	Compressor	179
Menu 4- My system	88	4-way valve	179
Menu 5- Service	89	Expansion valve	179
		HSB60-W	180
		<b>Temperature sensor</b>	181
		Data for sensor in outdoor unit	181
		<b>Component positions</b>	182
		Indoor units	182
		Outdoor unit	189
		<b>Accessories</b>	190
		Accessory parts	190
		Option parts (for PT tank)	192
		Wind protection	194
		<b>Piping system</b>	196











When install the unit, be sure to check whether the selection of installation place, power source specifications, usage limitation (piping length, height differences between indoor and outdoor units, power source voltage and etc.) and installation spaces.

## SAFETY PRECAUTIONS













- We recommend you to read this "SAFETY PRECAUTIONS" carefully before the installation work in order to gain full advantage of the functions of the unit and to avoid malfunction due to mishandling.
- The precautions described below are divided into [⚠WARNING] and [⚠CAUTION]. The matters with possibilities leading to serious consequences such as death or serious personal injury due to erroneous handling are listed in the [⚠WARNING] and the matters with possibilities leading to personal injury or damage of the unit due to erroneous handling including probability leading to serious consequences in some cases are listed in [⚠CAUTION]. These are very important precautions for safety. Be sure to observe all of them without fail.
- Be sure to confirm no anomaly on the equipment by commissioning after completed installation and explain the operating methods as well as the maintenance methods of this equipment to the user according to the owner's manual.
- Keep the installation manual together with owner's manual at a place where any user can read at any time. Moreover if necessary, ask to hand them to a new user

### ⚠WARNING













<ul style="list-style-type: none"> <li>● <b>Installation must be carried out by the qualified installer.</b> If you install the system by yourself, it may cause serious trouble such as water leaks, electric shocks, fire and personal injury , as a result of a system malfunction.</li> </ul>	
<ul style="list-style-type: none"> <li>● <b>Install the system in full accordance with the instruction manual.</b> Incorrect installation may cause bursts, personal injury, water leaks, electric shocks and fire.</li> </ul>	
<ul style="list-style-type: none"> <li>● <b>Use the original accessories and the specified components for installation.</b> If parts other than those prescribed by us are used, It may cause water leaks, electric shocks, fire and personal injury.</li> </ul>	
<ul style="list-style-type: none"> <li>● <b>When installing in small rooms, take prevention measures not to exceed the density limit of refrigerant in the event of leakage.</b> Consult the expert about prevention measures. If the density of refrigerant exceeds the limit in the event of leakage, lack of oxygen can occur, which can cause serious accidents.</li> </ul>	
<ul style="list-style-type: none"> <li>● <b>Ventilate the working area well in the event of refrigerant leakage during installation.</b> If the refrigerant comes into contact with naked flames, poisonous gas is produced.</li> </ul>	
<ul style="list-style-type: none"> <li>● <b>After completed installation, check that no refrigerant leaks from the system.</b> If refrigerant leaks into the room and comes into contact with an oven or other hot surface, poisonous gas is produced.</li> </ul>	
<ul style="list-style-type: none"> <li>● <b>Hang up the unit at the specified points with ropes which can support the weight in lifting for portage. And to avoid jolting out of alignment, be sure to hang up the unit at 4-point support.</b> An improper manner of portage such as 3-point support can cause death or serious personal injury due to falling of the unit.</li> </ul>	
<ul style="list-style-type: none"> <li>● <b>Install the unit in a location with good support.</b> Unsuitable installation locations can cause the unit to fall and cause material damage and personal injury.</li> </ul>	
<ul style="list-style-type: none"> <li>● <b>Ensure the unit is stable when installed, so that it can withstand earthquakes and strong winds.</b> Unsuitable installation locations can cause the unit to fall and cause material damage and personal injury.</li> </ul>	
<ul style="list-style-type: none"> <li>● <b>Ensure that no air enters in the refrigerant circuit when the unit is installed and removed.</b> If air enters in the refrigerant circuit, the pressure in the refrigerant circuit becomes too high, which can cause burst and personal injury.</li> </ul>	
<ul style="list-style-type: none"> <li>● <b>The electrical installation must be carried out by the qualified electrician in accordance with "the norm for electrical work" and "national wiring regulation", and the system must be connected to the dedicated circuit.</b> Power supply with insufficient capacity and incorrect function done by improper work can cause electric shocks and fire.</li> </ul>	
<ul style="list-style-type: none"> <li>● <b>Be sure to shut off the power before starting electrical work.</b> Failure to shut off the power can cause electric shocks, unit failure or incorrect function of equipment.</li> </ul>	
<ul style="list-style-type: none"> <li>● <b>Be sure to use the cables conformed to safety standard and cable ampacity for power distribution work.</b> Unconformable cables can cause electric leak, anomalous heat production or fire.</li> </ul>	
<ul style="list-style-type: none"> <li>● <b>Use the prescribed cables for electrical connection, tighten the cables securely in terminal block and relieve the cables correctly to prevent overloading the terminal blocks.</b> Loose connections or cable mountings can cause anomalous heat production or fire.</li> </ul>	
<ul style="list-style-type: none"> <li>● <b>Arrange the wiring in the control box so that it cannot be pushed up further into the box. Install the service panel correctly.</b> Incorrect installation may result in overheating and fire.</li> </ul>	
<ul style="list-style-type: none"> <li>● <b>Do not perform brazing work in the airtight room.</b> It can cause lack of oxygen.</li> </ul>	
<ul style="list-style-type: none"> <li>● <b>Use the prescribed pipes, flare nuts and tools for R32 or R410A.</b> Using existing parts (for R22 or R407C) can cause the unit failure and serious accidents due to burst of the refrigerant circuit.</li> </ul>	
<ul style="list-style-type: none"> <li>● <b>Tighten the flare nut by using double spanners and torque wrench according to prescribed method. Be sure not to tighten the flare nut too much.</b> Loose flare connection or damage on the flare part by tightening with excess torque can cause burst or refrigerant leaks which may result in lack of oxygen.</li> </ul>	

<p>● <b>Do not open the service valves for liquid line and gas line until completed refrigerant piping work, air tightness test and evacuation.</b> If the compressor is operated in state of opening service valves before completed connection of refrigerant piping work, air can be sucked into refrigerant circuit, which can cause burst or personal injury due to anomalously high pressure in the refrigerant.</p>	
<p>● <b>Do not put the drainage pipe directly into drainage channels where poisonous gases such as sulphide gas can occur.</b> Poisonous gases will flow into the room through drainage pipe and seriously affect the user's health and safety</p>	
<p>● <b>Only use prescribed option parts. The installation must be carried out by the qualified installer.</b> If you install the system by yourself, it can cause serious trouble such as water leaks, electric shocks, fire.</p>	
<p>● <b>Do not run the unit with removed panels or protections.</b> Touching rotating equipments, hot surfaces or high voltage parts can cause personal injury due to entrapment, burn or electric shocks.</p>	
<p>● <b>Be sure to fix up the service panels.</b> Incorrect fixing can cause electric shocks or fire due to intrusion of dust or water.</p>	
<p>● <b>Do not perform any repairs or modifications by yourself. Consult the dealer if the unit requires repair.</b> If you repair or modify the unit, it can cause water leaks, electric shocks or fire.</p>	
<p>● <b>Do not perform any change of protective device itself or its setup condition.</b> The forced operation by short-circuiting protective device of pressure switch and temperature controller or the use of non specified component can cause fire or burst.</p>	
<p>● <b>Be sure to switch off the power source in the event of installation, inspection or servicing.</b> If the power source is not shut off, there is a risk of electric shocks, unit failure or personal injury due to the unexpected start of fan.</p>	
<p>● <b>Consult the dealer or an expert regarding removal of the unit.</b> Incorrect installation can cause water leaks, electric shocks or fire.</p>	
<p>● <b>Stop the compressor before disconnecting refrigerant pipes in case of pump down operation.</b> If disconnecting refrigerant pipes in state of opening service valves before compressor stopping, air can be sucked, which can cause burst or personal injury due to anomalously high pressure in the refrigerant circuit.</p>	

 **CAUTION**

<p>● <b>Carry out the electrical work for ground lead with care.</b> Do not connect the ground lead to the gas line, water line, lightning conductor or telephone line's ground lead. Incorrect grounding can cause unit faults such as electric shocks due to short-circuiting.</p>	
<p>● <b>Use the circuit breaker with sufficient breaking capacity.</b> If the breaker does not have sufficient breaking capacity, it can cause the unit malfunction and fire.</p>	
<p>● <b>Earth leakage breaker must be installed.</b> If the earth leakage breaker is not installed, it can cause electric shocks.</p>	
<p>● <b>Do not use any materials other than a fuse with the correct rating in the location where fuses are to be used.</b> Connecting the circuit with copper wire or other metal thread can cause unit failure and fire.</p>	
<p>● <b>Do not install the unit near the location where leakage of combustible gases can occur.</b> If leaked gases accumulate around the unit, it can cause fire.</p>	
<p>● <b>Do not install the unit where corrosive gas (such as sulfuric acid gas etc.) or combustible gas (such as thinner and petroleum gases) can accumulate or collect, or where volatile combustible substances are handled.</b> Corrosive gas can cause corrosion of heat exchanger, breakage of plastic parts and etc. And combustible gas can cause fire.</p>	
<p>● <b>Secure a space for installation, inspection and maintenance specified in the manual.</b> Insufficient space can result in accident such as personal injury due to falling from the installation place.</p>	
<p>● <b>When the outdoor unit is installed on a roof or a high place, provide permanent ladders and handrails along the access route and fences and handrails around the outdoor unit.</b> If safety facilities are not provided, it can cause personal injury due to falling from the installation place.</p>	
<p>● <b>Do not use the indoor unit at the place where water splashes may occur such as in laundries.</b> Since the indoor unit is not waterproof, it can cause electric shocks and fire.</p>	
<p>● <b>Do not install nor use the system close to the equipment that generates electromagnetic fields or high frequency harmonics.</b> Equipment such as inverters, standby generators, medical high frequency equipments and telecommunication equipments can affect the system, and cause malfunctions and breakdowns. The system can also affect medical equipment and telecommunication equipment, and obstruct its function or cause jamming.</p>	
<p>● <b>Do not install the outdoor unit in a location where insects and small animals can inhabit.</b> Insects and small animals can enter the electric parts and cause damage or fire. Instruct the user to keep the surroundings</p>	
<p>● <b>Do not use the base flame for outdoor unit which is corroded or damaged due to long periods of operation.</b> Using an old and damage base flame can cause the unit falling down and cause personal injury.</p>	
<p>● <b>Do not install the unit in the locations listed below.</b></p> <ul style="list-style-type: none"> <li>• Locations where carbon fiber, metal powder or any powder is floating.</li> <li>• Locations where any substances that can affect the unit such as sulphide gas, chloride gas, acid and alkaline can occur.</li> <li>• Vehicles and ships.</li> <li>• Locations where cosmetic or special sprays are often used.</li> <li>• Locations with direct exposure of oil mist and steam such as kitchen and machine plant.</li> <li>• Locations where any machines which generate high frequency harmonics are used.</li> <li>• Locations with salty atmospheres such as coastlines.</li> </ul>	

- Locations with heavy snow. (If installed, be sure to provide base flame and snow hood mentioned in the manual)
  - Locations where the unit is exposed to chimney smoke.
  - Locations at high altitude. (more than 1000m high)
  - Locations with ammoniac atmospheres.
  - Locations where heat radiation from other heat source can affect the unit.
  - Locations without good air circulation.
  - Locations with any obstacles which can prevent inlet and outlet air of the unit.
  - Locations where short circuit of air can occur. (in case of multiple units installation)
  - Locations where strong air blows against the air outlet of outdoor unit.
- It can cause remarkable decrease in performance, corrosion and damage of components, malfunction and fire.

<p>● <b>Do not install the outdoor unit in the locations listed below.</b></p> <ul style="list-style-type: none"> <li>• Locations where discharged hot air or operating sound of the outdoor unit can bother neighborhood.</li> <li>• Locations where outlet air of the outdoor unit blows directly to plants.</li> <li>• Locations where vibration can be amplified and transmitted due to insufficient strength of structure.</li> <li>• Locations where vibration and operation sound generated by the outdoor unit can affect seriously. (on the wall or at the place near bed room)</li> <li>• Locations where an equipment affected by high harmonics is placed. (TV set or radio receiver is placed within 5m)</li> <li>• Locations where drainage cannot run off safely.</li> </ul> <p>It can affect surrounding environment and cause a claim.</p>	
<p>● <b>Do not install the remote control at the direct sunlight.</b></p> <p>It can cause malfunction or deformation of the remote control.</p>	
<p>● <b>Do not use the unit for special purposes such as storing foods, cooling precision instruments and preservation of animals, plants or art.</b></p> <p>It can cause the damage of the items.</p>	
<p>● <b>Take care when carrying the unit by hand.</b></p> <p>If the unit weights more than 20kg, it must be carried by two or more persons. Do not carry by the plastic straps, always use the carry handle when carrying the unit by hand. Use gloves to minimize the risk of cuts by the aluminum fins.</p>	
<p>● <b>Dispose of any packing materials correctly.</b></p> <p>Any remaining packing materials can cause personal injury as it contains nails and wood. And to avoid danger of suffocation, be sure to keep the plastic wrapper away from children and to dispose after tear it up.</p>	
<p>● <b>Pay attention not to damage the drain pan by weld spatter when welding work is done near the indoor unit.</b></p> <p>If weld spatter entered into the indoor unit during welding work, it can cause pin-hole in drain pan and result in water leakage. To prevent such damage, keep the indoor unit in its packing or cover it.</p>	
<p>● <b>Be sure to insulate the refrigerant pipes so as not to condense the ambient air moisture on them.</b></p> <p>Insufficient insulation can cause condensation, which can lead to moisture damage on the ceiling, floor, furniture and any other valuables.</p>	
<p>● <b>Be sure to perform air tightness test by pressurizing with nitrogen gas after completed refrigerant piping work.</b></p> <p>If the density of refrigerant exceeds the limit in the event of refrigerant leakage in the small room, lack of oxygen can occur, which can cause serious accidents.</p>	
<p>● <b>Do not touch any buttons with wet hands.</b></p> <p>It can cause electric shocks.</p>	
<p>● <b>Do not shut off the power source immediately after stopping the operation.</b></p> <p>Wait at least 5 minutes, otherwise there is a risk of water leakage or breakdown.</p>	
<p>● <b>Do not control the system with main power switch.</b></p> <p>It can cause fire or water leakage. In addition, the fan can start unexpectedly, which can cause personal injury.</p>	
<p>● <b>Do not touch any refrigerant pipes with your hands when the system is in operation.</b></p> <p>During operation the refrigerant pipes become extremely hot or extremely cold depending the operating condition, and it can cause burn injury or frost injury.</p>	

### Notabilia for units designed for R32

- Do not use any refrigerant other than R32. R32 will rise to pressure about 1.6 times higher than that of a conventional refrigerant (R22 or R407C). A cylinder containing R32 has a light blue indication mark on the top.
- In charging refrigerant, always take it out from a cylinder in the liquid phase.
- All indoor units must be models designed exclusively for R32. Check connectable indoor unit models in a catalog, etc. (A wrong indoor unit, if connected into the system, will impair proper system operation)

Dedicated tools for R32 or R410A	
a)	Gauge manifold
b)	Charge hose
c)	Electronic scale for refrigerant charge
d)	Vacuum pump
e)	Flaring tool set
f)	Protrusion control gauge for copper pipe
g)	Vacuum pump adapter
h)	Gas leak detector

## Technical data

## Technical specifications

### Specifications

#### Indoor units

#### Split box

Model	HSB60-W
<b>General conditions</b>	
Power source	230V 50Hz
Recommended fuse	6 A
Pipe size refrigerant (ref)	Gas: OD12.7, liquid: OD6.35 (1/2"; 1/4")
Capacity	For 6kW outdoor unit
<b>Indoor unit (split type, splitbox)</b>	
IP grade	IP21
Connection water system	Compression fitting 22mm
Connection refrigerant system	Flare
Maximum allowed water pressure	1.0MPa
Maximum allowed water temperature	90 °C
Maximum allowed refrigerant pressure	4.15MPa
Maximum allowed refrigerant temperature	110°C
Supply heating temperature range	25 – 58°C
Supply cooling temperature range	7 – 25°C
Heat exchanger	Plate heat exchanger Alfa Laval ACH18-52H-F
Total volume heat exchanger (water side)	1 ℓ
Water quality	≤ EU-directive nr. 98/83/EF
Ambient conditions	5 – 35°C Max relative humidity 95%
Height	400mm
Width	460mm
Depth	250mm
Weight netto	16kg
Weight including packaging	19kg
Part number MHIAE	MCD001A016
<b>Enclosed</b>	
	Wall bracket for mounting
	Ball valve with particle filter



## Tank unit

Model	PT300
Volume total	279 ℓ
Volume coil	9.4 ℓ
Area coil	1.6m <sup>2</sup>
Material coil	Steel - S235 $\phi$ 33.7 × 2.6mm
Material tank	Steel – S275 g=3.0mm
Cabinet	Side / Top / – plate (PS)
Material	Side – plate polystyrene g=1mm Top - plate polystyrene g=2mm
Color (powder coated 1 layer)	Side – White Top – RAL7001
Isolation tank	EPS200 (30kg/ m <sup>3</sup> ) + Nonwoven PET (1kg/m <sup>2</sup> )
Stand by heat loss	90W (PN-EN 12897:2016;(EU) No 812/2013)
Design pressure tank	1.0MPa (10bar)
Design pressure coil	1.6MPa (16bar)
Power coil 70/10/45°C (2,5m <sup>3</sup> /h)	26kW
Efficiency coil 70/10/45°C	640ℓ/h
Water quality sanitary hot water	≤EU directive nr.98/83/EF
Water quality, system	≤EU directive nr.98/83/EF
Max operating temperature tank	85°C
Min operating temperature tank	5°C
Max operating temperature coil	110°C
Connection water system	G1" external thread
Connection sanitary hot water	G1" external thread
Inner surface corrosion protection	Enamel - DIN 4753-3:2013 - Part 3
Corrosion protection	Mg-anode
Height, (adjustment)	1634mm (20 <sub>+15/-0</sub> )
Min required ceiling height	2000mm
Width	$\phi$ 673mm
Depth	743mm
Weight netto product	115kg
Weight incl pallet incl packing	140kg
Weight packaging: Wood	29kg
Weight packaging: EPS	0.5kg
Weight packaging: Plastics	0.1kg
Packaging volume /dim	1.1m <sup>3</sup> / 1840 × 790 × 750 (mm)
Part number MHIAE	MCD001A009

## Technical specifications

### Outdoor unit

Adapted to RoHS directive

Outdoor model			FDCW60VNX-W	
Indoor unit heat exchanger			ACH18-52H-F	
Power source			1 phase 230V 50Hz	
Heating nominal capacity	condition 1		kW	2.70
	condition 2	High capacity	kW	5.08
		Low capacity	kW	2.64
Heating power consumption	condition 1		kW	0.88
	condition 2	High capacity	kW	0.99
		Low capacity	kW	0.49
COP	condition 1			3.06
	condition 2	High capacity		5.16
		Low capacity		5.42
Cooling nominal capacity	condition 1		kW	5.31
	condition 2		kW	7.54
Cooling power consumption	condition 1		kW	1.95
	condition 2		kW	2.11
EER	condition 1			2.73
	condition 2			3.57
Operation range (Outdoor temperature)			Heating	-20 — 43
			Cooling	15 — 43
Operation range (Water temperature)			Heating	25 - 58 (65 with immersion heater)
			Cooling	7 — 25
System water flow			ℓ/s	0.09 — 0.29
Min system water flow at 100% circulation pump speed			ℓ/s	0.19
Max current			A	15
Recommended fuse rating			A	20
Starting current			A	5
Deviation, incoming supply				-15 — +10%
Max refrigerant pipe length			m	30
Max height difference between IU and OU			m	20
Outdoor unit	Height		mm	640
	Width		mm	800
	Depth		mm	290
	Weight		kg	46
	Color			Stucco white
	IP grade			IPX4
	Sound power level*1		dB(A)	52
	Sound power level (Silent mode)		dB(A)	56
	Sound power level (Max)		dB(A)	65
	Sound power level		dB(A)	44
	Air flow (Cooling/Heating)		m <sup>3</sup> /min	41.5/39.0
	Type of compressor			RMT5113SWE11 (Twin rotary type)
	Starting method			Direct line start
	Refrigerant oil		liter	0.45 M-MB75
	Heat exchanger			M shape fin & inner grooved tubing
	Ref control			Capillary tube+EEV
	Defrost control			Reversing cycle
	Fan			Propeller fan x 1
	Fan motor		W	34 x 1
	Shock & vibration absorber			Rubber sleeve (for compressor)
	Electric heater (crankcase/base)		W	-/110
	Safety equipment			Overload protection for fan motor Frost protection thermostat Internal thermostat for fan motor Abnormal discharge temperature protection
	Power and signal line from indoor unit			3 cores 2.0mm <sup>2</sup> + 2 cores 1.5mm <sup>2</sup>
	Refrigerant			R32
	Refrigerant volume (pipe length without additional charge)		kg (m)	1.30 (15)
	Dimensions, refrigerant pipe		mm (inch)	Gas pipe: OD 12.7 (1/2"), Liquid pipe: OD 6.35 (1/4")
Refrigerant pipe connections			Flare	
Drain			Hole size: φ20 × 5 pcs.	
Insulation for piping			Necessary (both Liquid & Gas lines)	
Part number MHIAE			PCA003F147	

**Test conditions**

		Water temperature	Ambient temperature
Heating	condition 1	45°C out / 40°Cin	7°CDB / 6°CWB
	condition 2	35°Cout / 30°Cin	
Cooling	condition 1	7°Cout / 12°Cin	35°CDB
	condition 2	18°Cout / 23°Cin	

\*1: Test condition for sound power level

Temperature condition: Heating condition 2, Low capacity

\*2: Test condition for sound pressure level

Mike position 1m away in front of outdoor unit at the height of 1m

\*3: According to EN255-3

**Seasonal space heating energy efficiency ( $\eta_s$ ) & Rated heat output (Prated)****Split box****Medium-temperature application**

Outdoor unit	FDCW60VNX-W	
Indoor unit	HSB60-W	
Tank	PT300	
	Prated (kW)	$\eta_s$
$\eta_s$ 55 Average climate Seasonal Space Heating Energy Efficiency Class	5.3	137
	A++	
$\eta_s$ 55 Warmer climate	5.4	174
$\eta_s$ 55 Cold climate	5.7	115

**Low-temperature application**

Outdoor unit	FDCW60VNX-W	
Indoor unit	HSB60-W	
Tank	PT300	
	Prated (kW)	$\eta_s$
$\eta_s$ 35 Average climate Seasonal Space Heating Energy Efficiency Class	4.8	190
	A+++	
$\eta_s$ 35 Warmer climate	5.5	253
$\eta_s$ 35 Cold climate	5.8	153

Outdoor unit	FDCW60VNX-W	
Indoor unit	HSB60-W	
Tank	PT300	
	COP <sub>DHW</sub>	$\eta_{wh} (*1)$
$\eta_{wh}$ Average climate Energy Efficiency class	—	
$\eta_{wh}$ Warmer climate	—	
$\eta_{wh}$ Cold climate	—	
Load profile	XXL	

\*1 COP<sub>DHW</sub> / 2.5 \*100

This technical information is based on the European regulations listed below.

1. COMMISSION REGULATION (EU) No. 813/2013 of 2 August 2013 implementing Directive 2009/125/EC of the European Parliament and of the Council with regard to ecodesign requirements for space heaters and combination heaters.
2. COMMISSION DELEGATED REGULATION (EU) No. 811/2013 of 18 February 2013 supplementing Directive 2010/30/EU of the European Parliament and of the Council with regard to the energy labelling of space heaters, combination heaters, packages of space heater, temperature control and solar device and packages of combination heater, temperature control and solar device.

## Controller

<b>RC-HY 20-W</b>	
<b>Electrical data</b>	
Power source voltage	230V 50Hz
Enclosure class	IP 21
Rated value for impulse voltage	4 kV
Electrical contamination	2
<b>Option connections</b>	
Max number of air/water heat pumps	1
Max number of sensors	8
Max number of charge pumps	1
Max number of outputs for additional heat step	3
<b>Miscellaneous</b>	
Area of operation	- 25 – 70 °C
Ambient temperature	5 – 35 °C
<b>Dimensions and weight</b>	
Width	354mm
Depth	123mm
Height	400mm
Net weight	4.3kg
Gross weight	4.5kg
Part number MHIAE	MCD501A003
Internet connection function*	Included
Language	English, Swedish, German, French, Spanish, Finnish, Lithuanian, Czech, Polish, Dutch, Norwegian, Danish, Estonian, Latvian, Russian, Italian, Hungarian, Slovenian, Turkish, Croatian, Romanian, Icelandic

\*Function is provided by myUpTech AB., which monitors operation data and control unit through internet

**Technical specifications**

<b>RC-HY 40-W</b>	
<b>Electrical data</b>	
Power source voltage	230V 50Hz
Enclosure class	IP21
Rated value for impulse voltage	4kV
<b>Option connections</b>	
Max number of air/water heat pumps	8
Max number of sensors	8
Max number of charge pumps with internal accessory cards	4
Max number of charge pumps with external accessory cards	8
Max number of outputs for additional heat step	3
<b>Miscellaneous</b>	
Area of operation	- 25 – 70 °C
Ambient temperature	5 – 35 °C
<b>Dimensions and weight</b>	
Width	354mm
Depth	123mm
Height	400mm
Net weight	4.4kg
Gross weight	4.6kg
Part number MHIAE	MCD501A004
Internet connection function*	Included
Language	English, Swedish, German, French, Spanish, Finnish, Lithuanian, Czech, Polish, Dutch, Norwegian, Danish, Estonian, Latvian, Russian, Italian, Hungarian, Slovenian, Turkish, Croatian, Romanian, Icelandic

\*Function is provided by myUpTech AB., which monitors operation data and control unit through internet

## Installation requirements

Indoor unit	HSB60-W
Outdoor unit	FDCW60VNX-W
Highest recommended supply / return temperature	55/45°C
Max pressure, climate system	0.25MPa (2.5 bar)
Max temperature, climate system	65°C
Max temperature in indoor unit	65°C
Max temperature from external heat source	65°C
Max supply temperature with compressor	58°C
Min supply temperature cooling	7°C
Max supply temperature cooling	25°C
Min volume, climate system without underfloor cooling application	20ℓ
Min volume, climate system with underfloor cooling application	50ℓ
Max flow, climate system	0.29ℓ/s
Min flow, climate system	0.09ℓ/s
Nominal system flow heating ( $\Delta T=5K$ )	0.29ℓ/s (6kW, 7/45°C)
Nominal system flow cooling ( $\Delta T=5K$ )	0.29ℓ/s (6kW, 35/7°C)

External circulation pump must be used when the pressure drop in the system is greater than the available external pressure. In such case, a bypass line with non-return valve must be installed.

Use an overflow valve if system flow cannot be guaranteed.

Operating temperature range

FDCW60VNX-W

<Heating/Hot Water>

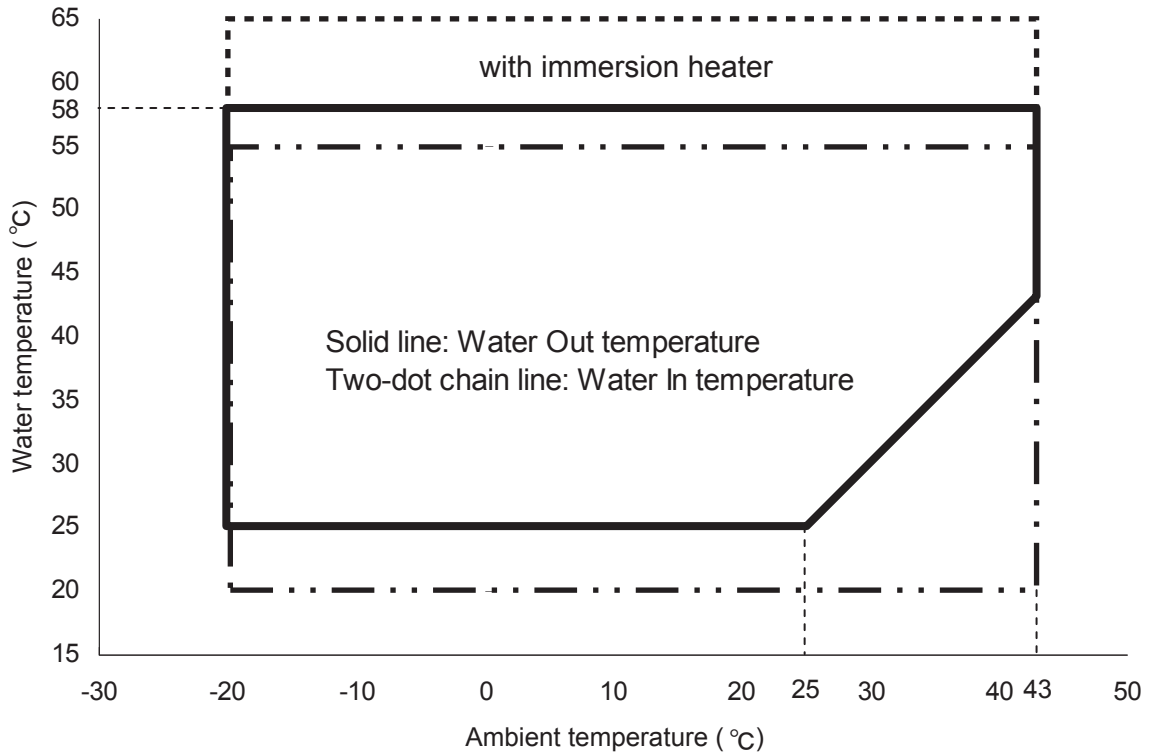

<Cooling>

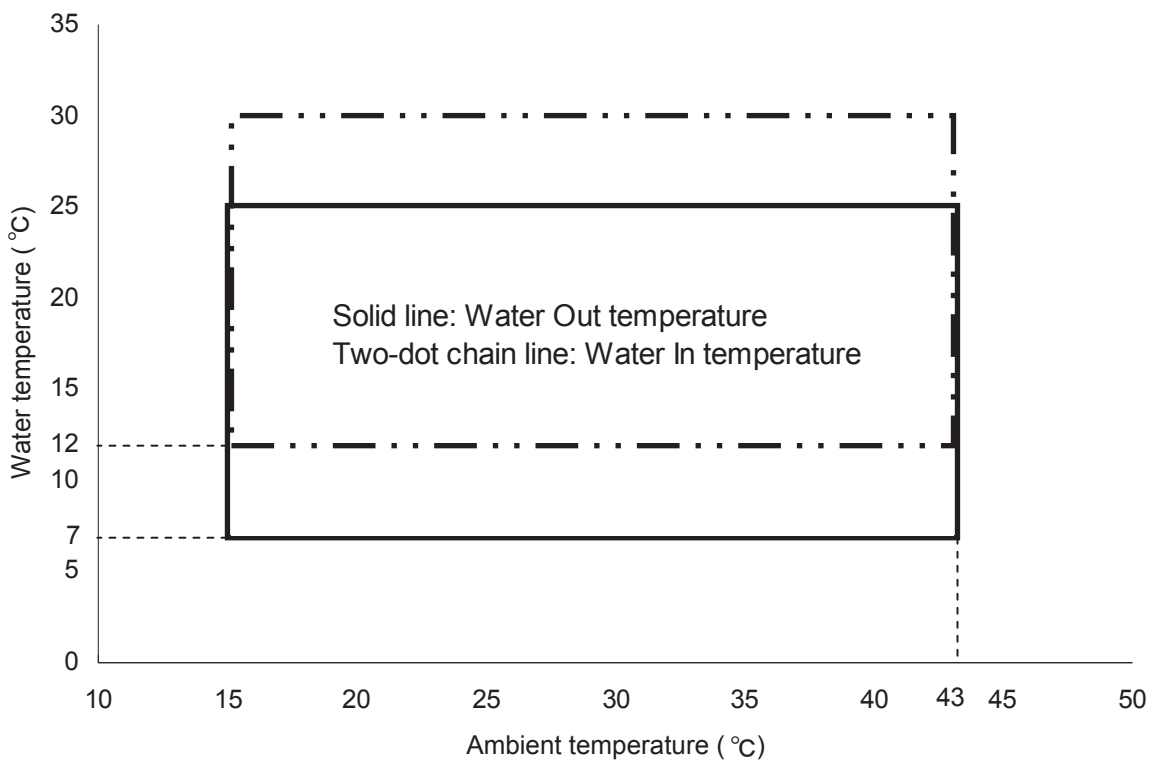



**NOTE**

- 1. Avoid installing outdoor unit where wind blows stronger than 5m/s. In strong wind environment, operable temperature range is drastically narrowed if wind protection is not used.*
- 2. In case outdoor unit is installed where outdoor air temperature drops below 10°C and wind blows directly into the outdoor unit, install wind protection on outdoor unit.  
If it is not observed, it will lead to abnormal stop.*

# Capacity diagram

HSB60-W – FDCW60VNX-W

## Heating

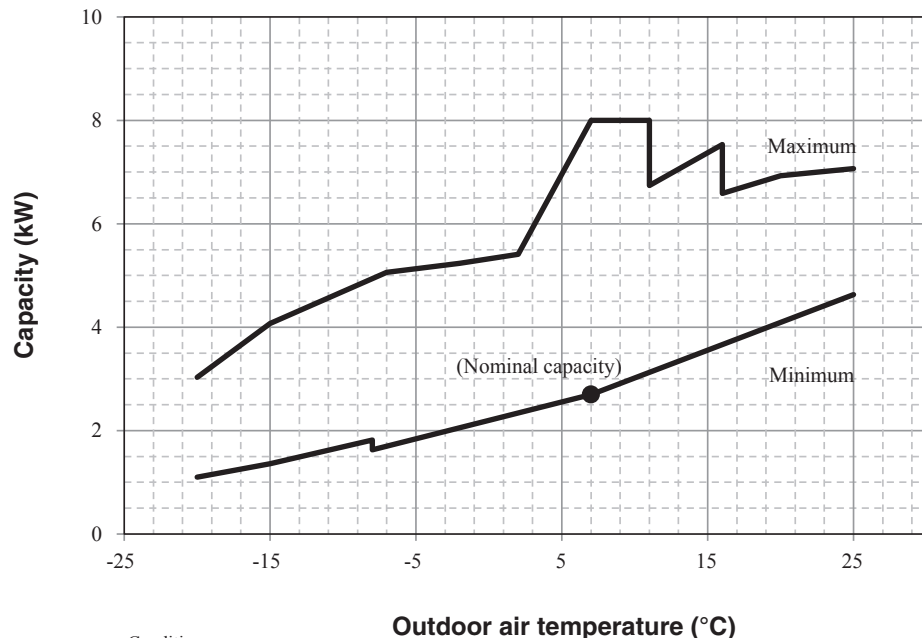

Condition  
Supply water temperature : 45°C  
Water flow rate : 1044 ℓ/h

## Cooling

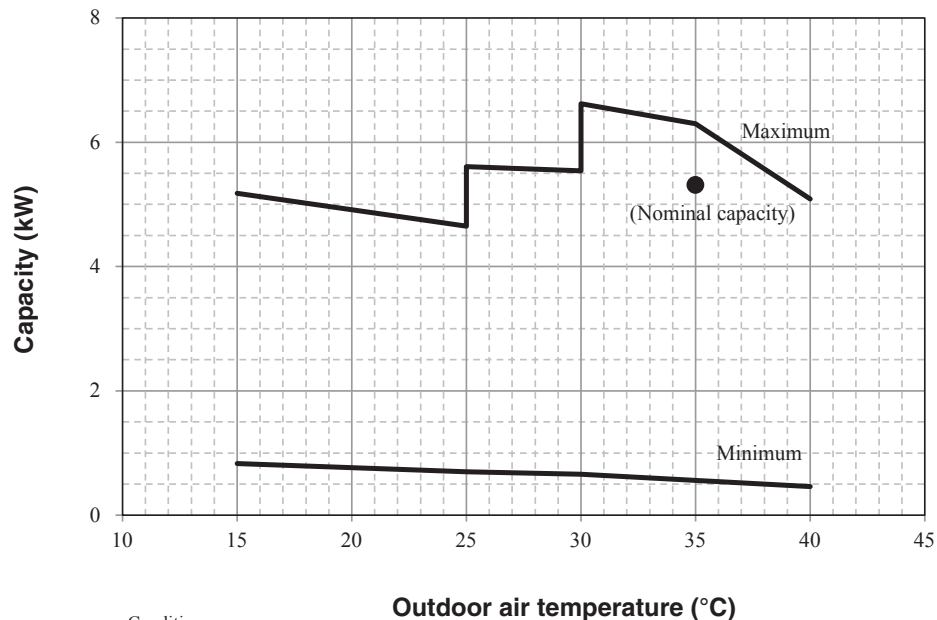

Condition  
Supply water temperature : 7°C  
Water flow rate : 1008 ℓ/h

**Capacity correction factor according to piping length and outlet water temperature in cooling**

**HSB60-W – FDCW60VNX-W**

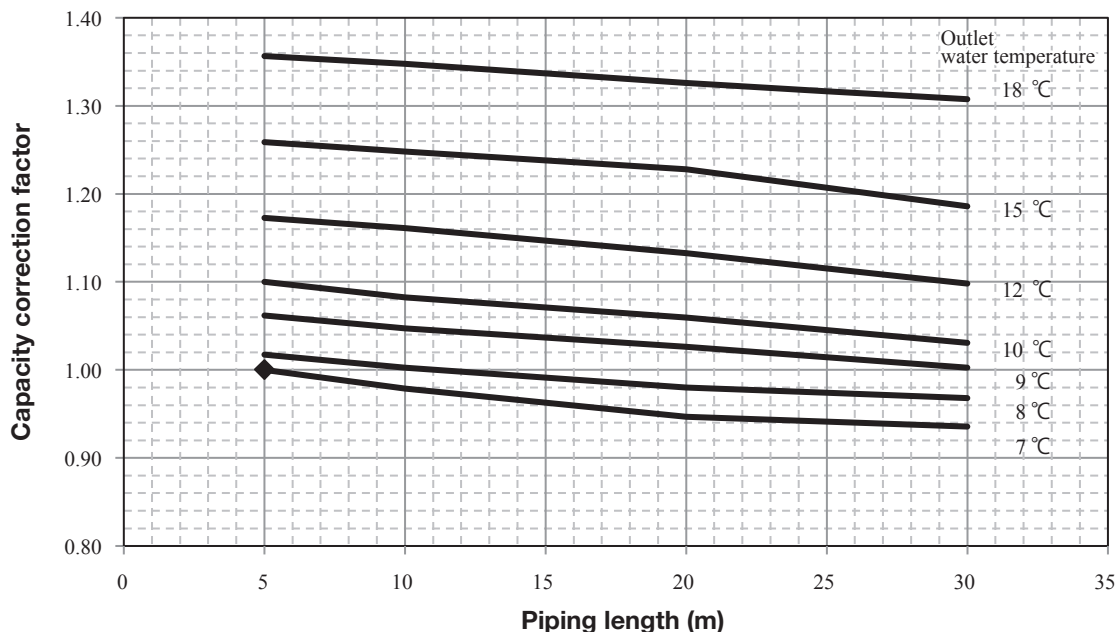

**How to calculate estimated capacity according to ambient temperature, water outlet temperature and piping length**

- (1) Read the cooling capacity at 7degC outlet and required ambient temperature.
- (2) Read the capacity correction factor at required water outlet temperature and piping length.
- (3) Multiply the values (1) and (2).

Example: HSB60-W, Ambient temperature 25degC, Water outlet 8degC, piping length 30m

- (1) Capacity at 25degC ambient and 7degC outlet: 5.6kW
- (2) Correction factor according to ambient temperature and piping length: 0.97
- (3) Estimated capacity:  $5.6 \times 0.97 = 5.4\text{kW}$

Note: The calculation result is only advisory and is not accurate.

# Dimensions

## Indoor units

### Split box

#### HSB60-W

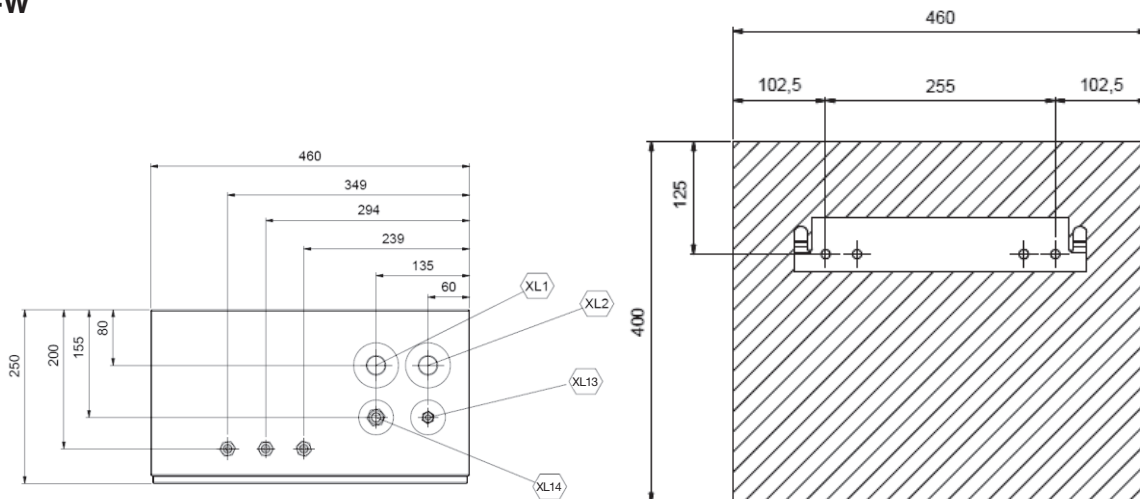

#### Meaning of symbol

Symbol	Contents	
XL1	Climate system supply	φ 22 mm
XL2	Climate system return	φ 22 mm
XL13	Connection, liquid line	1/4"
XL14	Connection, gas line	1/2"

Tank unit

PT300

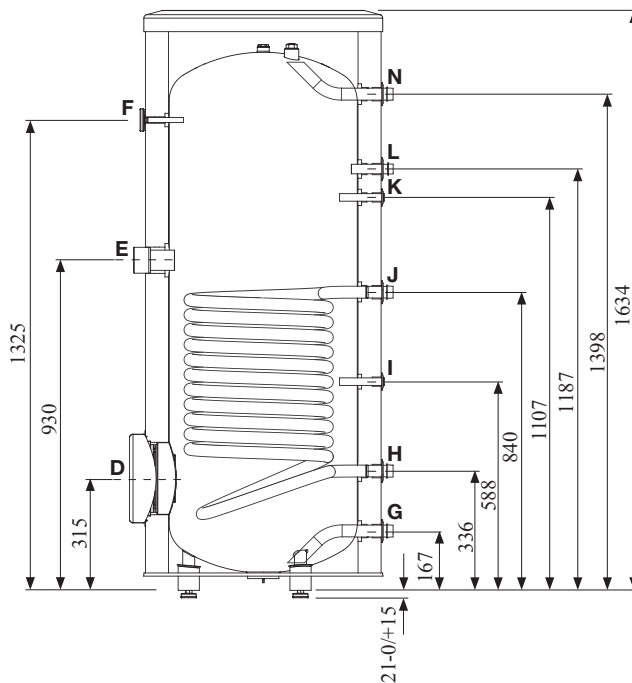
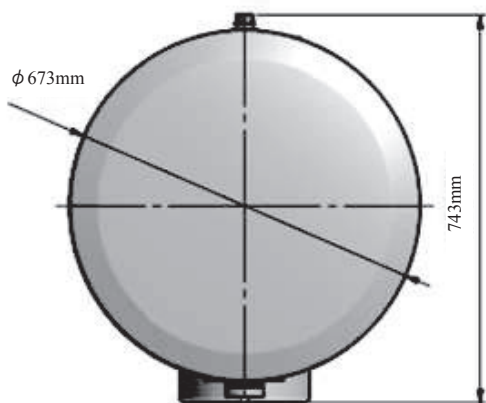
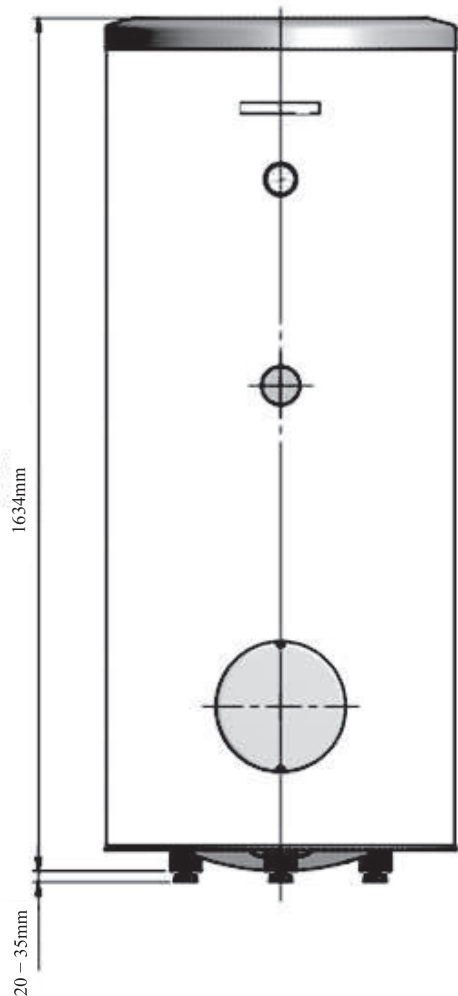

Connection			PT300
D	Inspection opening	mm	φ 120
E	Heating unit connection	inch	1½" Female
F	Thermometer enclosure	mm	φ 10 Female
N	Hot water outlet	inch	1" Male
L	Hot water circulation	inch	¾" Male
K	Temperature sensor enclosure (BT7)	mm	φ 16 Female
J	Coil supply	inch	1" Male
I	Temperature sensor enclosure (BT6)	mm	φ 16 Female
H	Return from coil	inch	1" Male
G	Cold water input	inch	1" Male

Outdoor unit

FDCW60VNX-W

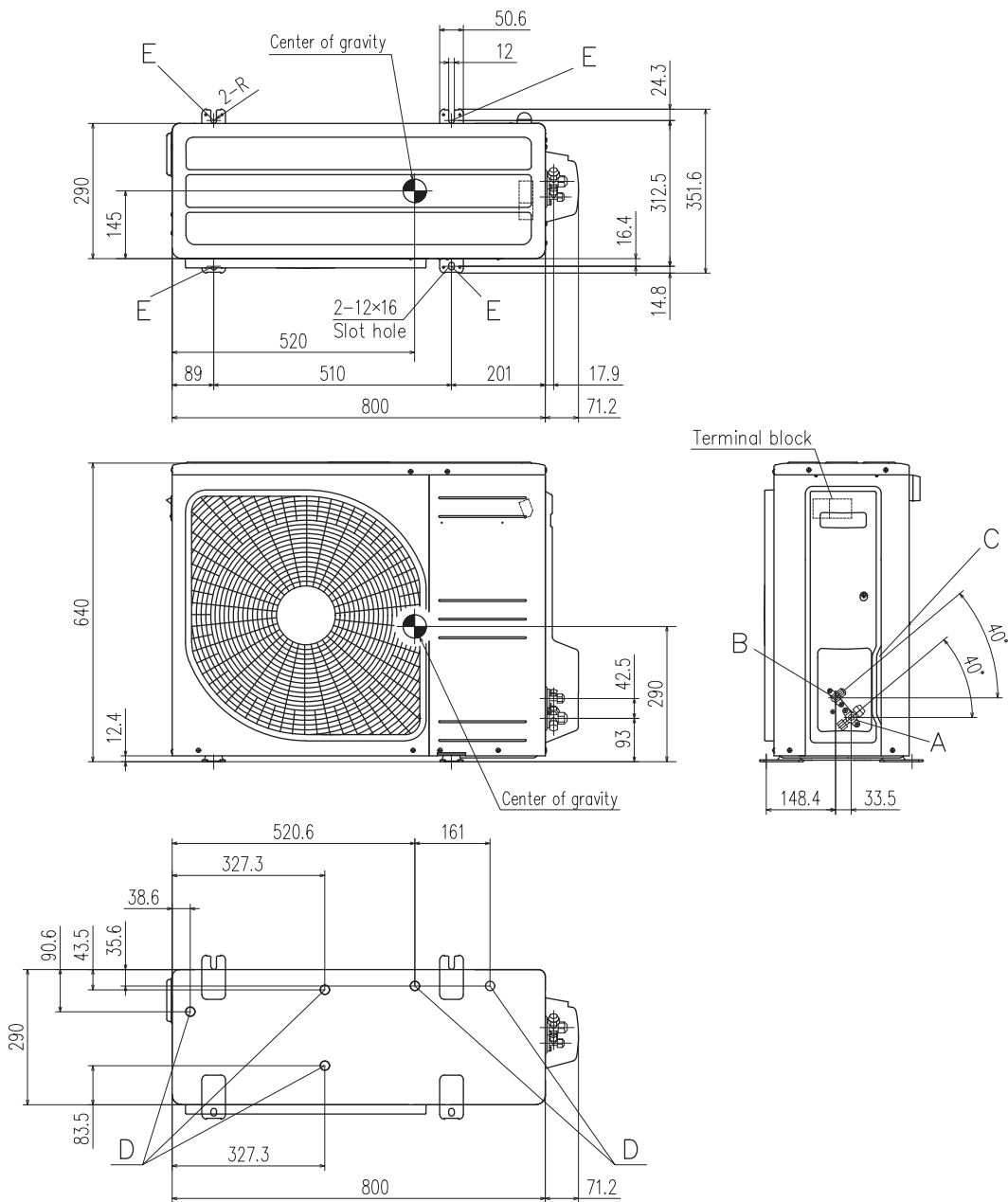

Meaning of symbol

Symbol	Content	
A	Service valve connection (gas side)	φ12.7 (1/2") (Flare)
B	Service valve connection (liquid side)	φ6.35 (1/4") (Flare)
C	Pipe/cable draw-out hole	
D	Drain discharge hole	φ20 × 5 places
E	Anchor bolt hole	M10 × 4 places

Notes

- (1) It must not be surrounded by walls on the four sides.
- (2) The unit must be fixed with anchor bolts. An anchor bolt must not protrude more than 15mm.
- (3) Where the unit is subject to strong winds, lay it in such a direction that the blower outlet faces perpendicularly to the dominant wind direction.
- (4) Leave 1m or more space above the unit.
- (5) A wall in front of the blower outlet must not exceed the unit height.
- (6) The model name label is attached on the lower right corner of the front panel.

**Controller**

**Outside : RC-HY20/40-W**

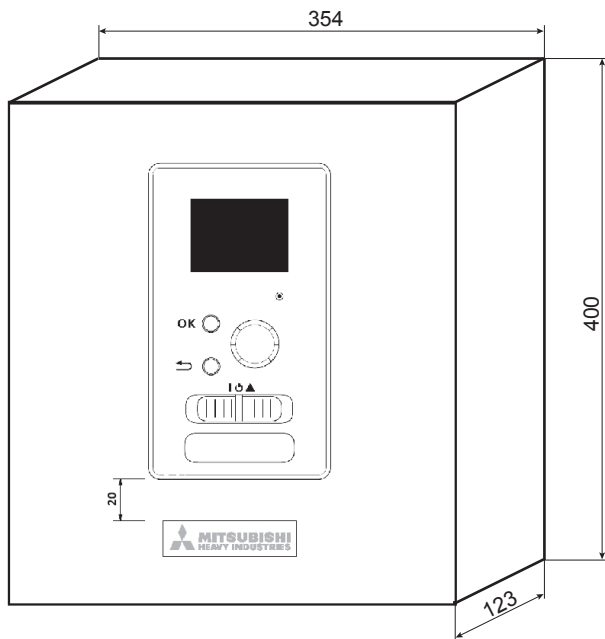

**Inside : RC-HY20-W**

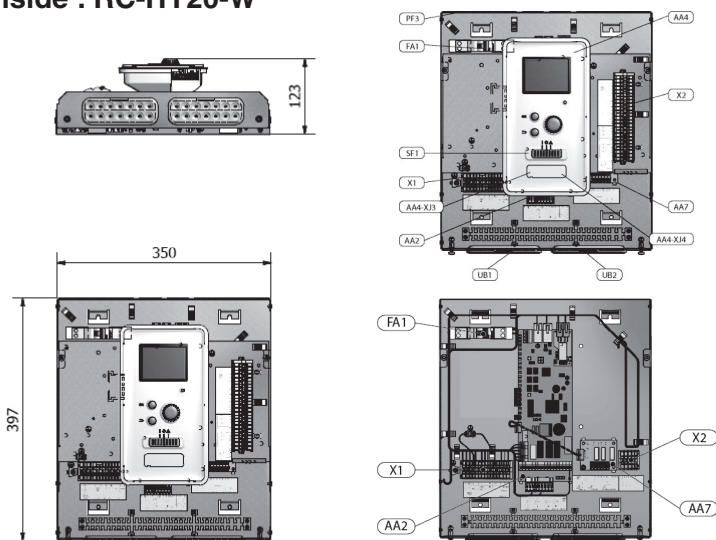

**Meaning of symbol**

Symbol	Contents
AA2	Base card
AA4	Display unit
AA4-XJ3	USB socket
AA4-XJ4	Service outlet (No function)
AA7	Extra relay circuit board
FA1	Miniature circuit breaker
X1	Terminal block, incoming electrical supply
X2	Terminal block, control signal circulation pump, sensors, AUX inputs and heat pump
SF1	Switch
PF3	Serial number plate
UB1	Cable grommet, incoming supply electricity, power for accessories
UB2	Cable gland, signal

Designations in components locations according to standard IEC 81346-1 and 81346-2

**Inside : RC-HY40-W**

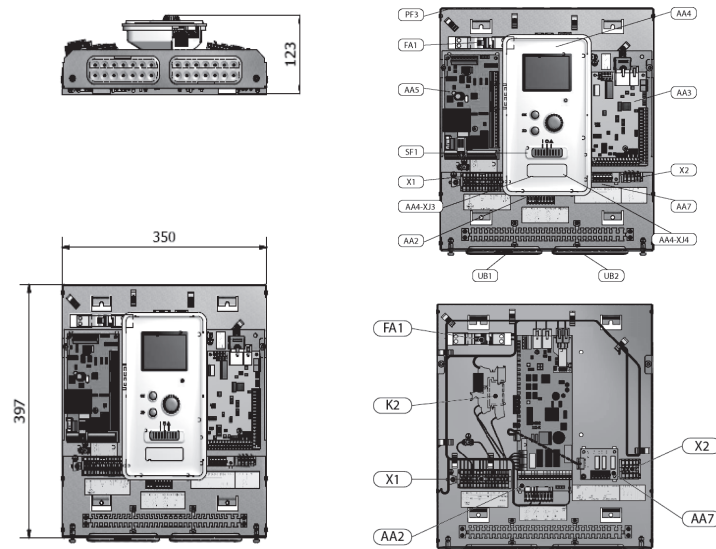

**Meaning of symbol**

Symbol	Contents
AA2	Base card
AA3	Input circuit board
AA4	Display unit
AA4-XJ3	USB socket
AA4-XJ4	Service outlet (No function)
AA5	Accessory board
AA7	Extra relay circuit board
FA1	Miniature circuit breaker
X1	Terminal block, incoming electrical supply
X2	Terminal block, AUX4 – AUX6
SF1	Switch
PF3	Serial number plate
UB1	Cable grommet, incoming supply electricity, power for accessories
UB2	Cable gland, signal

Designations in components locations according to standard IEC 81346-1 and 81346-2

# Electrical circuit diagram

Indoor unit

Split box

HSB60-W

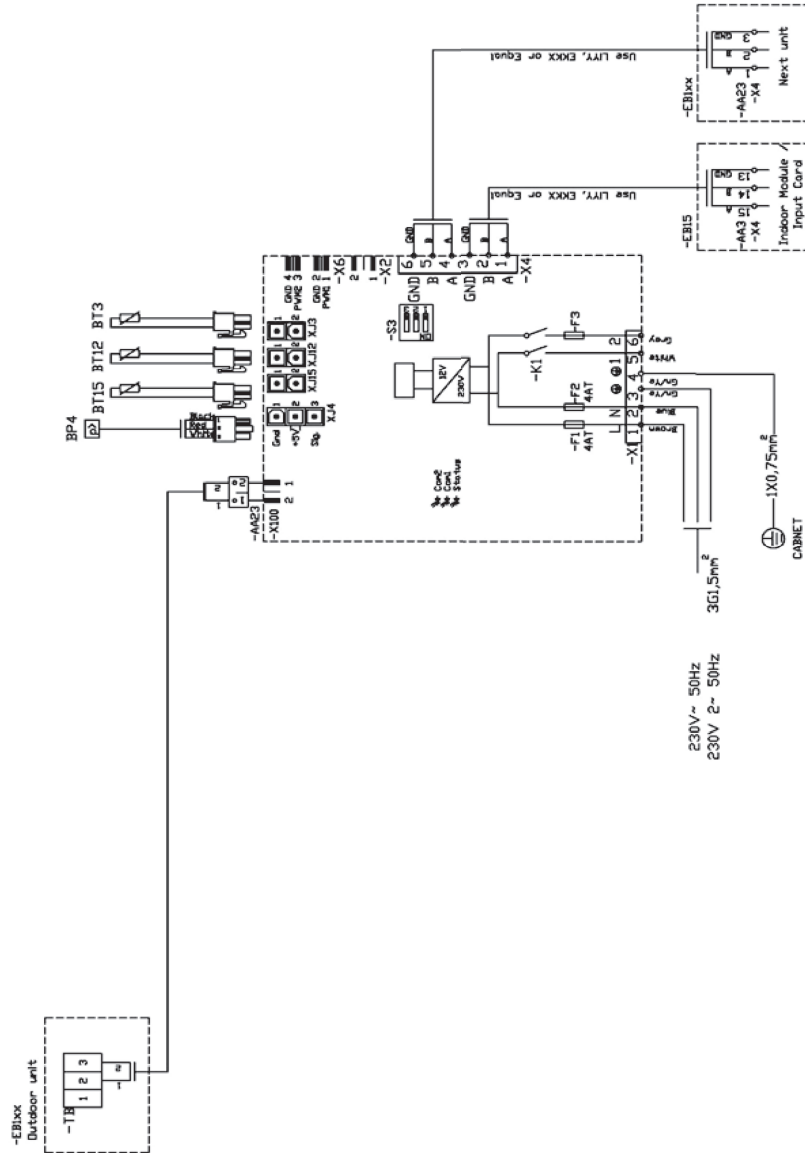



Outdoor unit  
FDCW60VNX-W

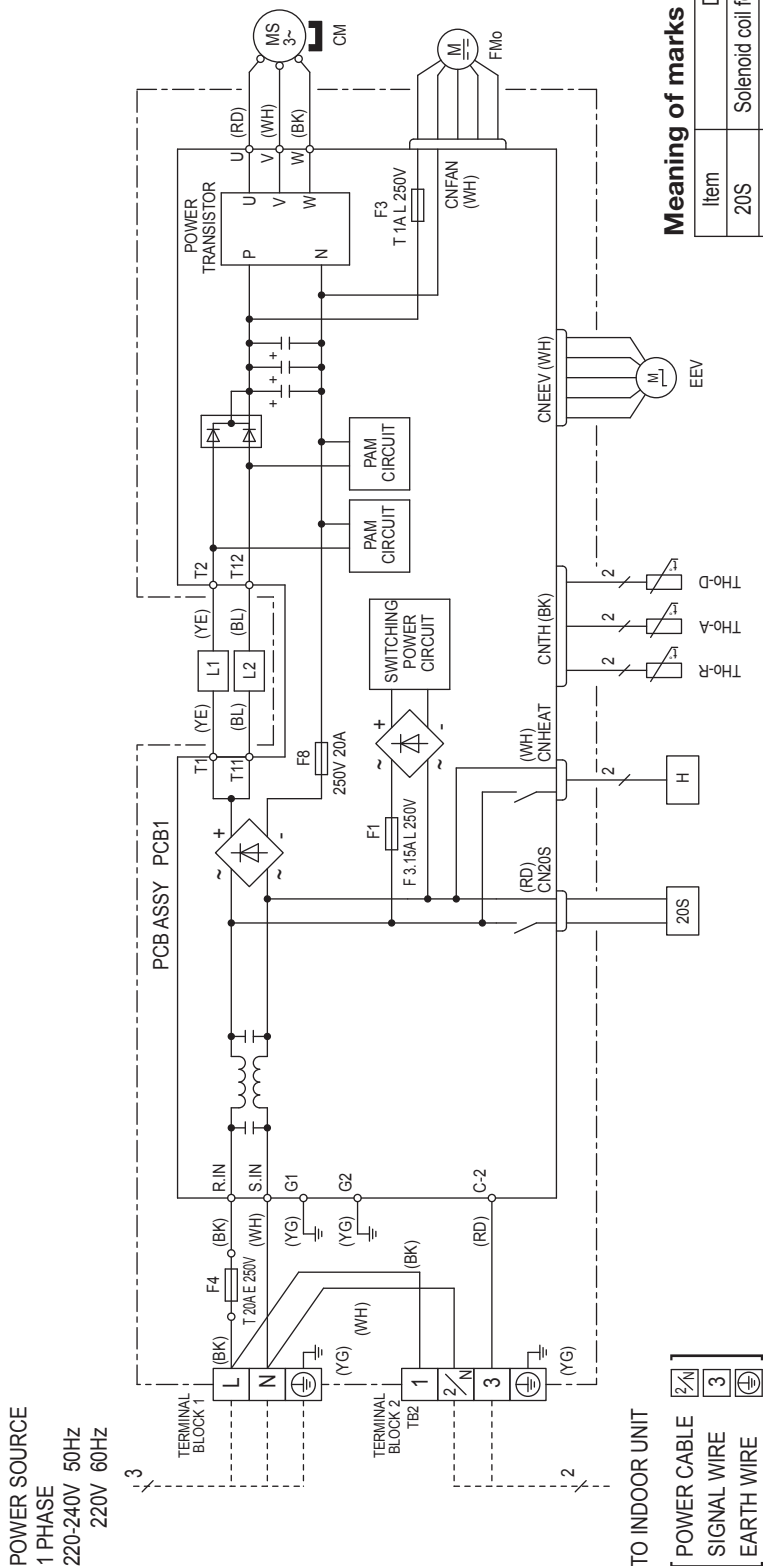

Meaning of marks

Item	Description
20S	Solenoid coil for 4-way valve
CN20S	Connector
CNEEV	
CNFAN	
CNTH	
CNHEAT	
CM	Compressor motor
EEV	Electric expansion valve(coil)
FMo	Fan motor
H	Heater
L1,2	Reactor
THo-R	Heat exchanger temperature sensor
THo-A	Outdoor air temperature sensor
THo-D	Discharge pipe temperature sensor

Color marks

Mark	Color
BK	Black
BL	Blue
RD	Red
WH	White
YE	Yellow
YG	Yellow/Green

Power cable, indoor-outdoor connecting wires

Model name	MAX running current (A)	Power cable wire size x number*	Power cable length (m)	Connecting cable wire size x number*
FDCW60VNX-W	15	2.0mm <sup>2</sup> x 3	13	1.5mm <sup>2</sup> x 2

- \* The wire numbers include Earth wire (Yellow/Green).
- Switchgear or circuit breaker capacity should be chosen according to national or regional electricity regulations.
- The power cable specifications are based on the assumption that a metal or plastic conduit is used with no more than three cables contained in a conduit and a voltage drop is 2%. For an installation falling outside of these conditions, please follow the national or regional electricity regulations.

Controller

RC-HY20-W - sheet 1

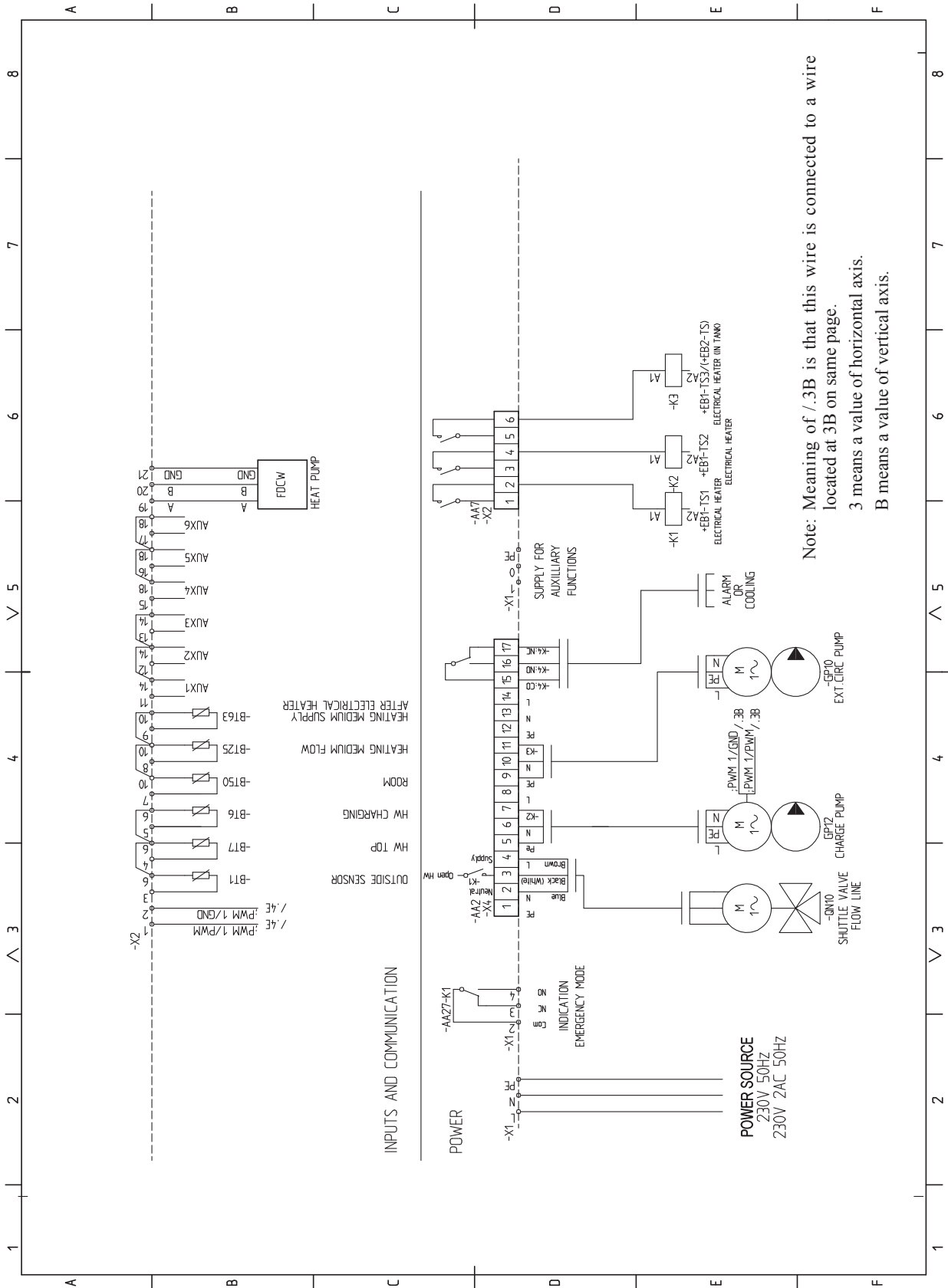

RC-HY20-W - sheet 2

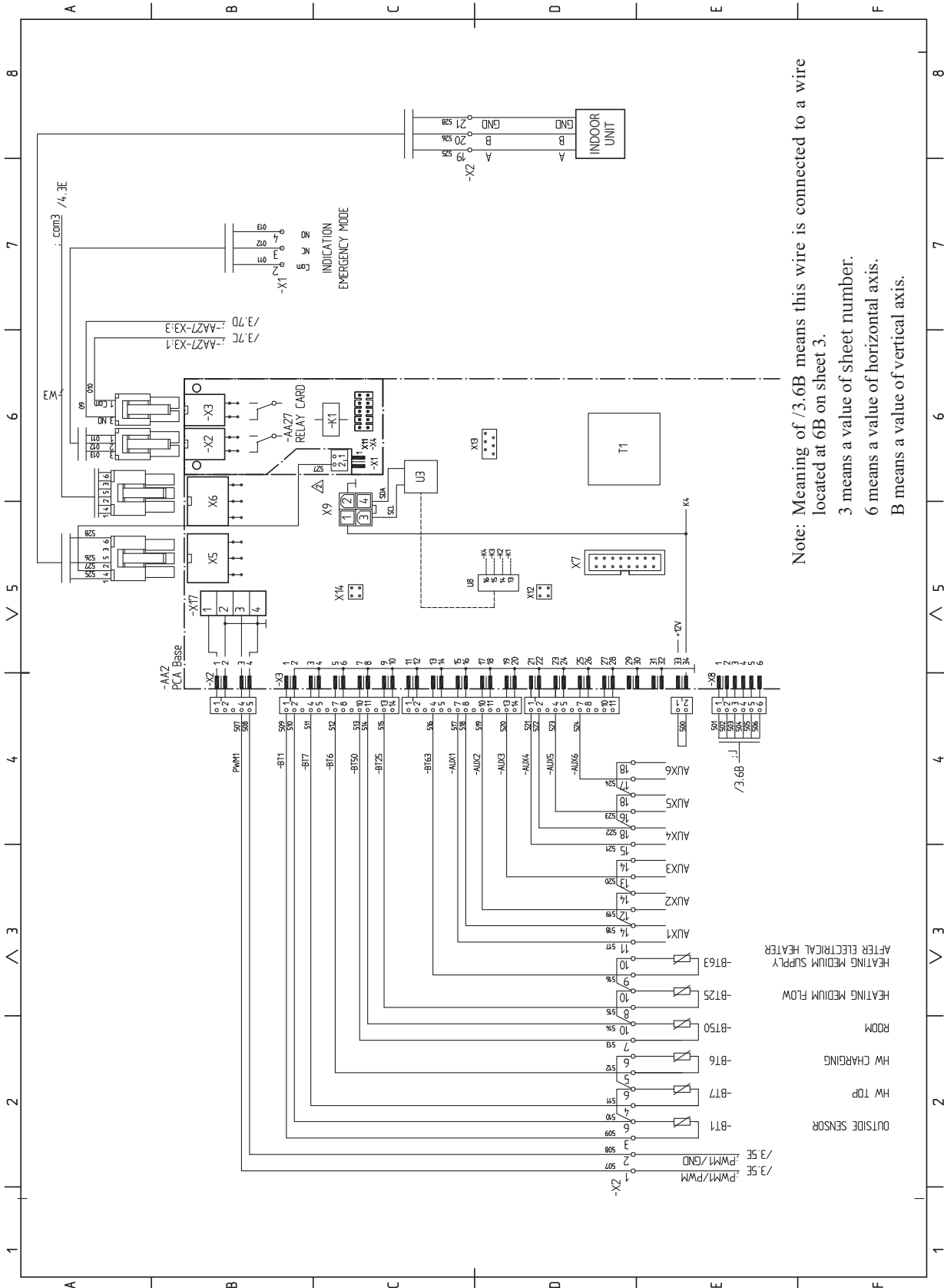

Note: Meaning of /3.6B means this wire is connected to a wire located at 6B on sheet 3.  
 3 means a value of sheet number.  
 6 means a value of horizontal axis.  
 B means a value of vertical axis.

RC-HY20-W - sheet 3

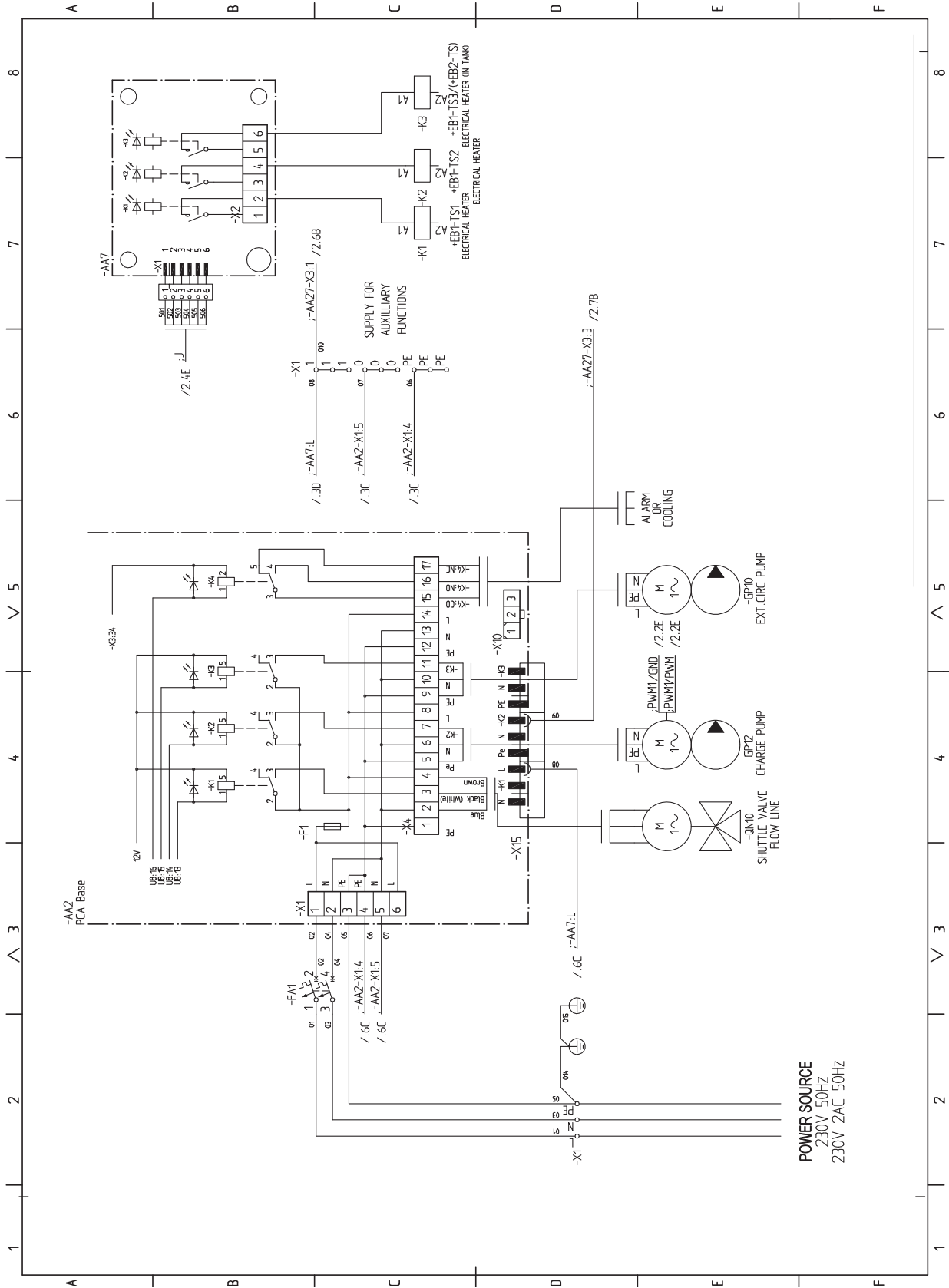

RC-HY20-W - sheet 4

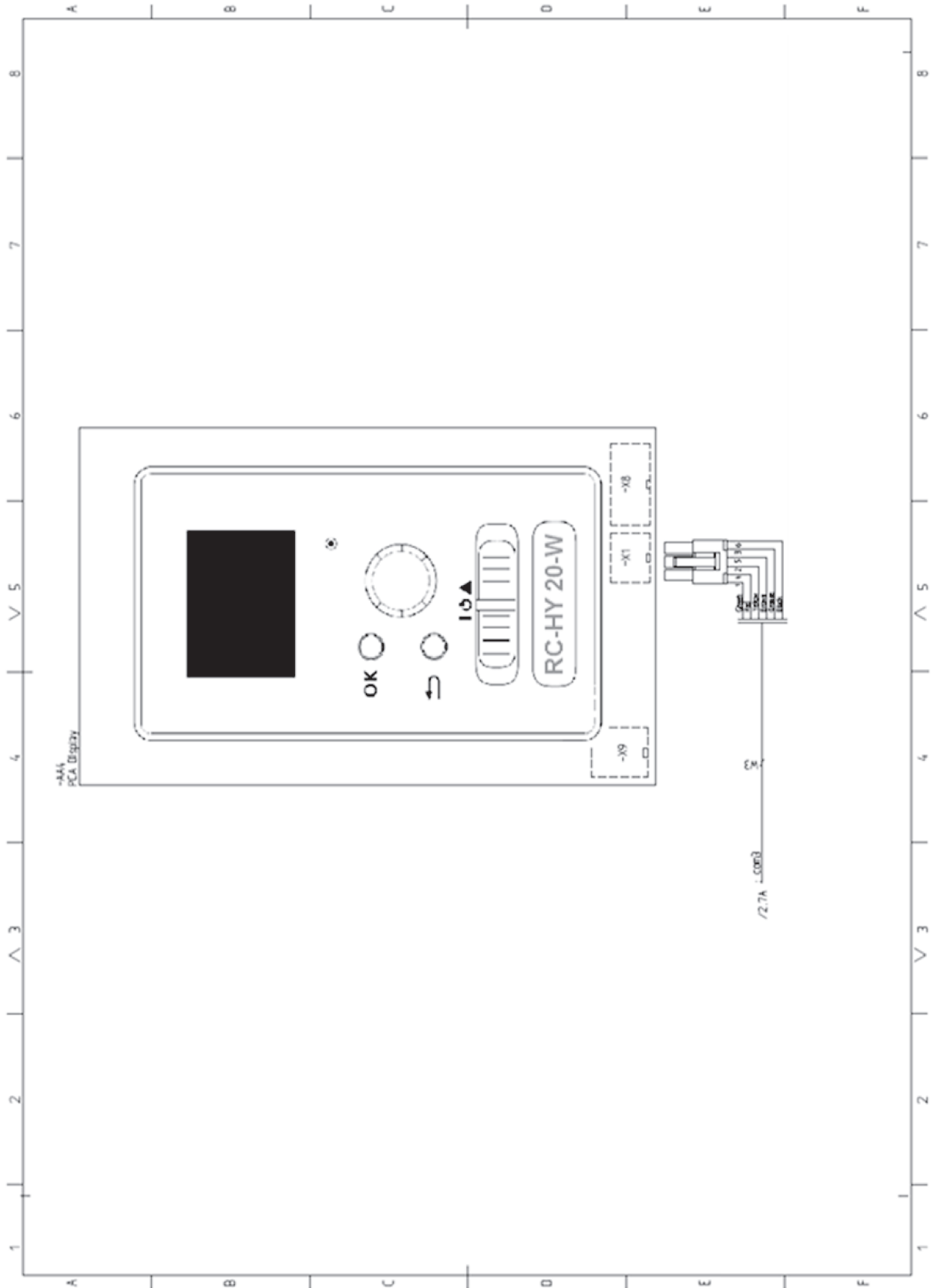

'20•HM-T-342C

Technical data

Electrical circuit diagram

RC-HY40-W- sheet 1

The diagram is a detailed electrical circuit diagram for the RC-HY40-W system, organized into a grid with vertical axis labels A-F and horizontal axis labels 1-8. It is divided into several functional sections:

- Inputs and Communication (Section C):** This section shows the connection of various sensors and control units to terminal blocks.
  - Terminal Block -AA3-X6:** Connected to sensors for OUTSIDE SENSOR (BT1), ROOM HEATING MEDIUM FLOW (BT2S, BT5), HW CHARGING (BT6), Aux 1, Aux 2, Aux 3, HW TOP (BT7), and HEATING MEDIUM RETURN (BT7A).
  - Terminal Block -AA5-X4:** Connected to two INDOOR UNIT (HSB) components and a Next Accessory Card (-AA5-X4).
  - Terminal Block -X2:** Connected to auxiliary relays AUX4, AUX5, and AUX6.
  - Terminal Block -X1:** Connected to a SHUTTLE VALVE FLOW LINE pump (M) and a CHARGE PUMP (M).
  - Terminal Block -X7:** Connected to an ALARM OR COOLING pump (M).
  - Terminal Block -X4:** Connected to a SHUTTLE VALVE FLOW LINE pump (M).
  - Terminal Block -X1:** Connected to a CHARGE PUMP (M).
  - Terminal Block -X1:** Connected to an EXT. CIRC. PUMP (M).
  - Terminal Block -X1:** Connected to a CHARGE PUMP (M).
  - Terminal Block -X1:** Connected to a CHARGE PUMP (M).
  - Terminal Block -X1:** Connected to a CHARGE PUMP (M).
- Power (Section D):** Shows the main power supply (230V 50HZ) connected to terminal block -X1. It includes emergency mode indicators and connections for emergency stop (K2).
- Power Source (Section E):** Specifies the power source as 230V 50HZ and 230V 2AC 50HZ.
- Control and Indication (Section F):** Shows connections for emergency mode indicators (K2), alarm or cooling (K3), and various pumps (M) controlled by PWM signals (e.g., PWM 1/GND, PWM 2/GND).
- Heating and Circulation (Section G):** Shows connections for various pumps (M) and heaters, including a SHUTTLE VALVE FLOW LINE pump, a CHARGE PUMP, an EXT. CIRC. PUMP, and a CHARGE PUMP.

Note: Meaning of /.3B is that this wire is connected to a wire located at 3B on same page.  
 3 means a value of horizontal axis.  
 B means a value of vertical axis.

- 28 -

RC-HY40-W- sheet 2

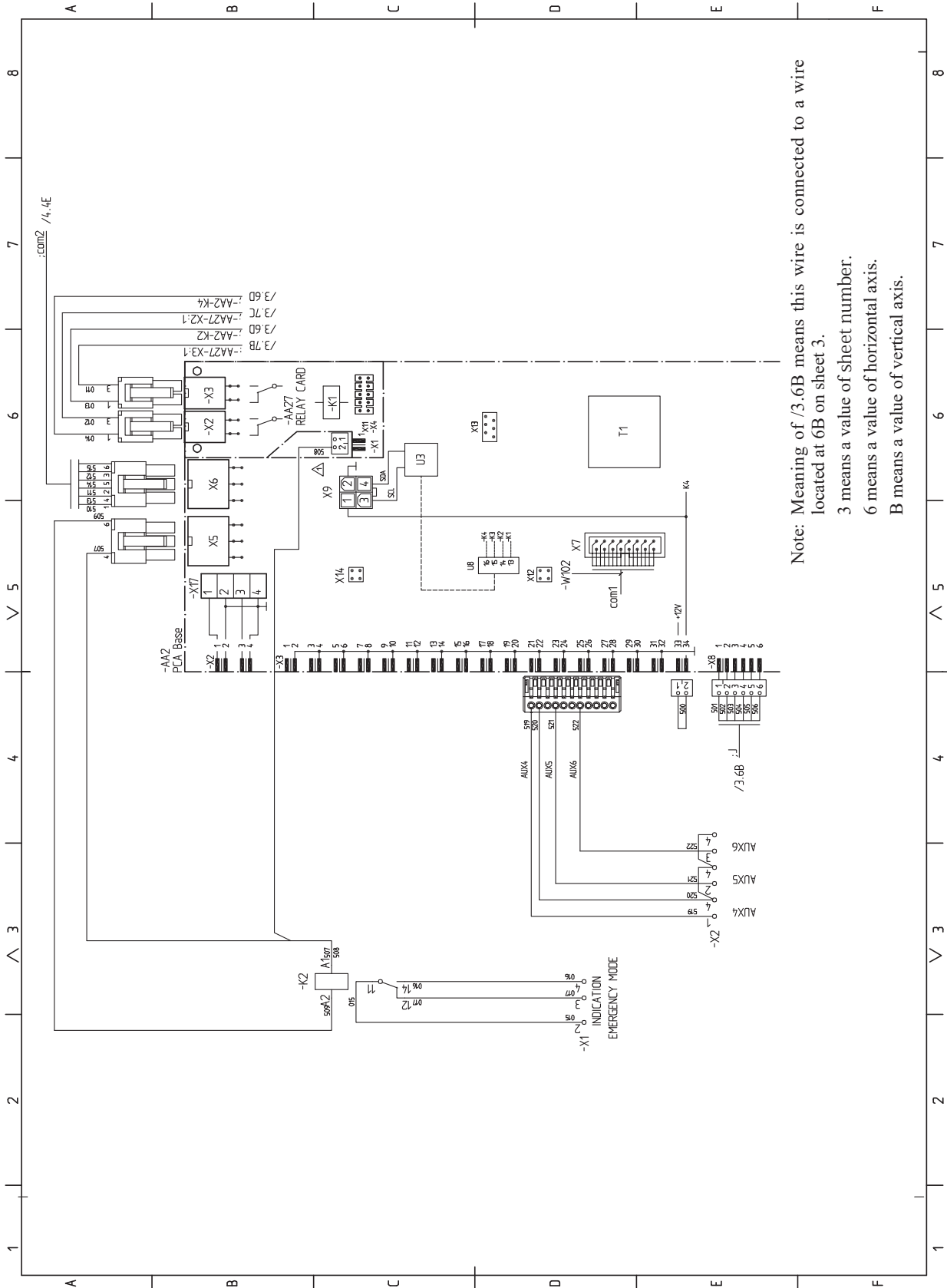

Note: Meaning of /3.6B means this wire is connected to a wire located at 6B on sheet 3.  
 3 means a value of sheet number.  
 6 means a value of horizontal axis.  
 B means a value of vertical axis.

RC-HY40-W- sheet 3

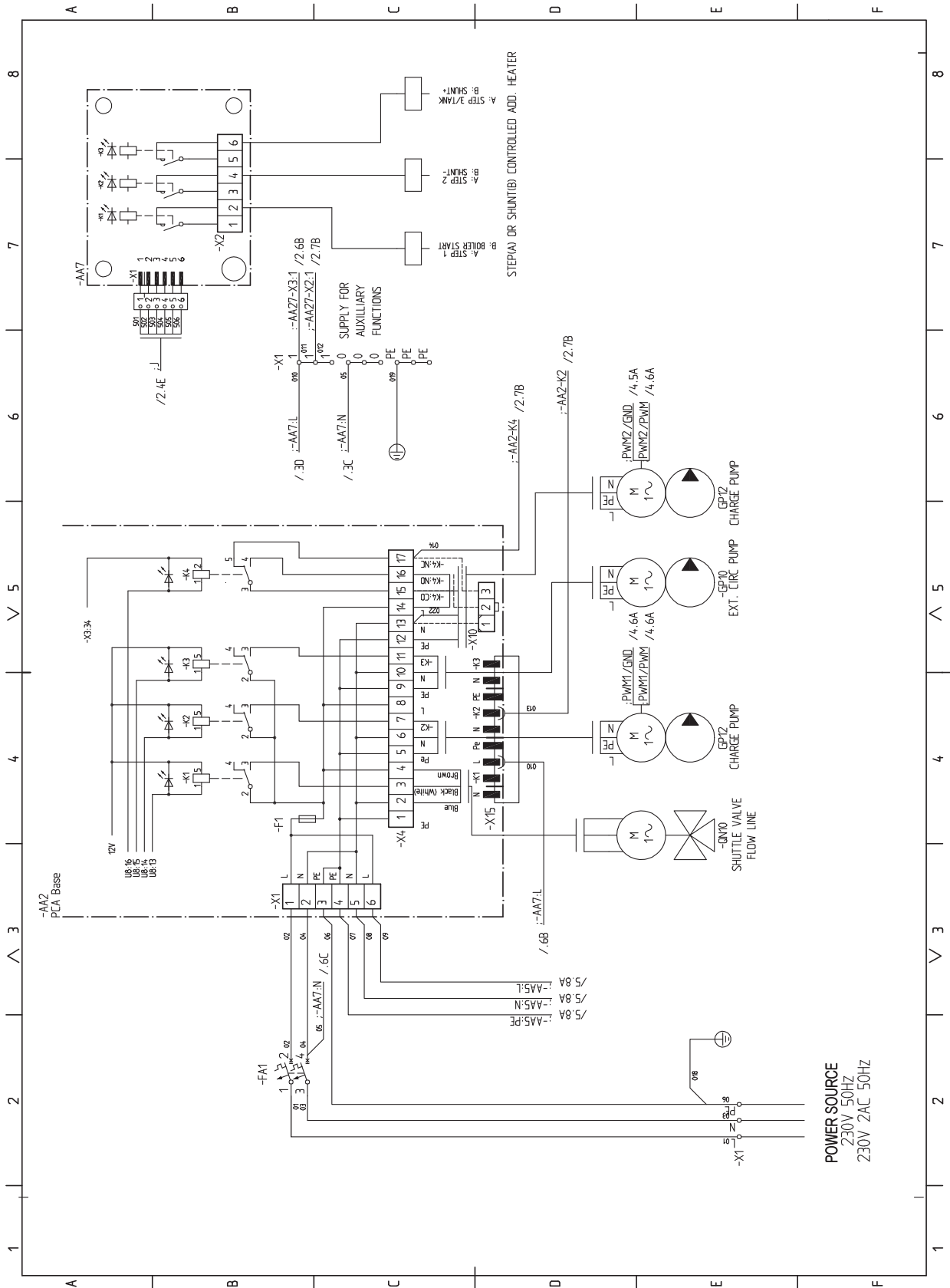



RC-HY40-W- sheet 4

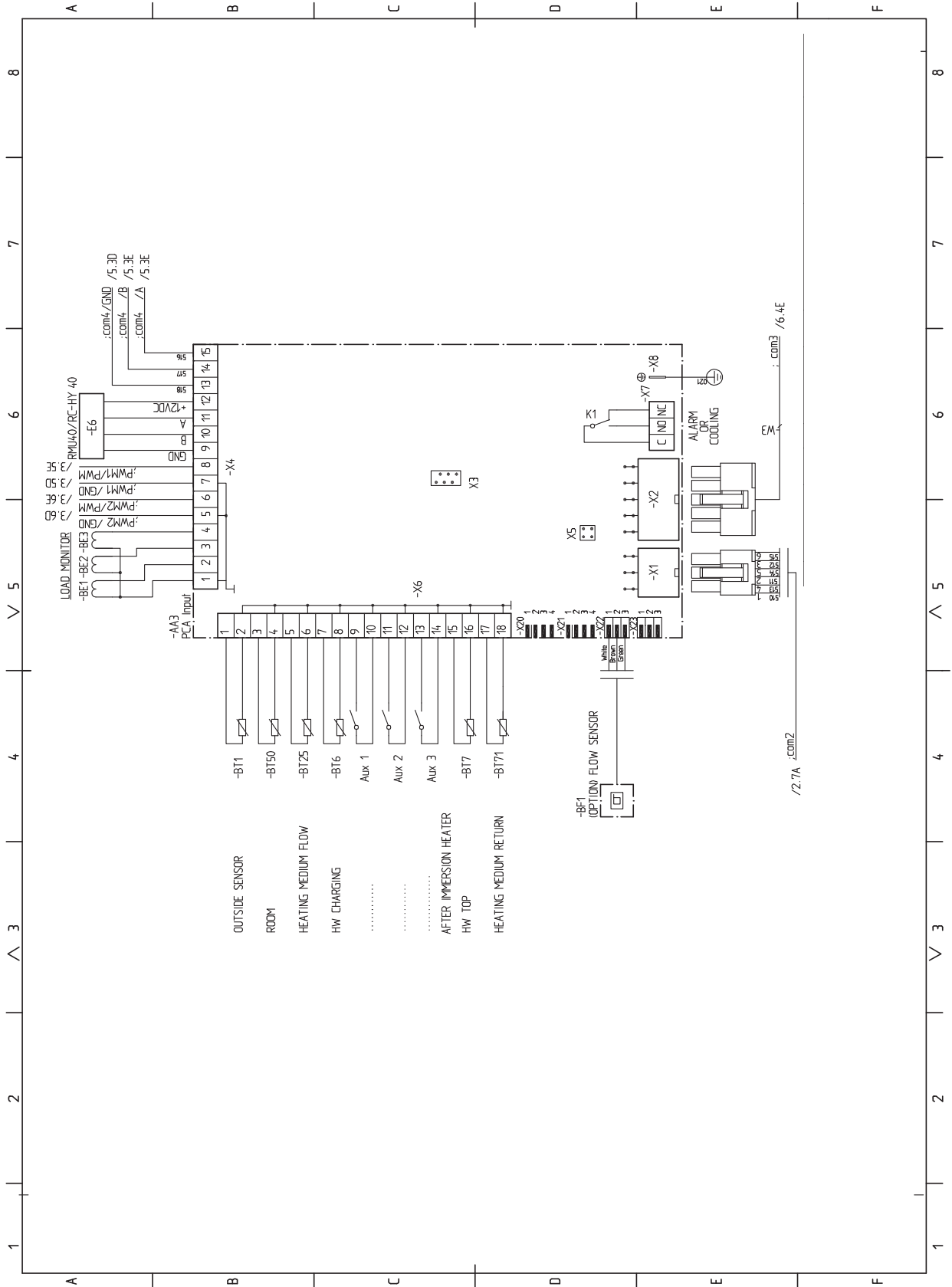

RC-HY40-W- sheet 5

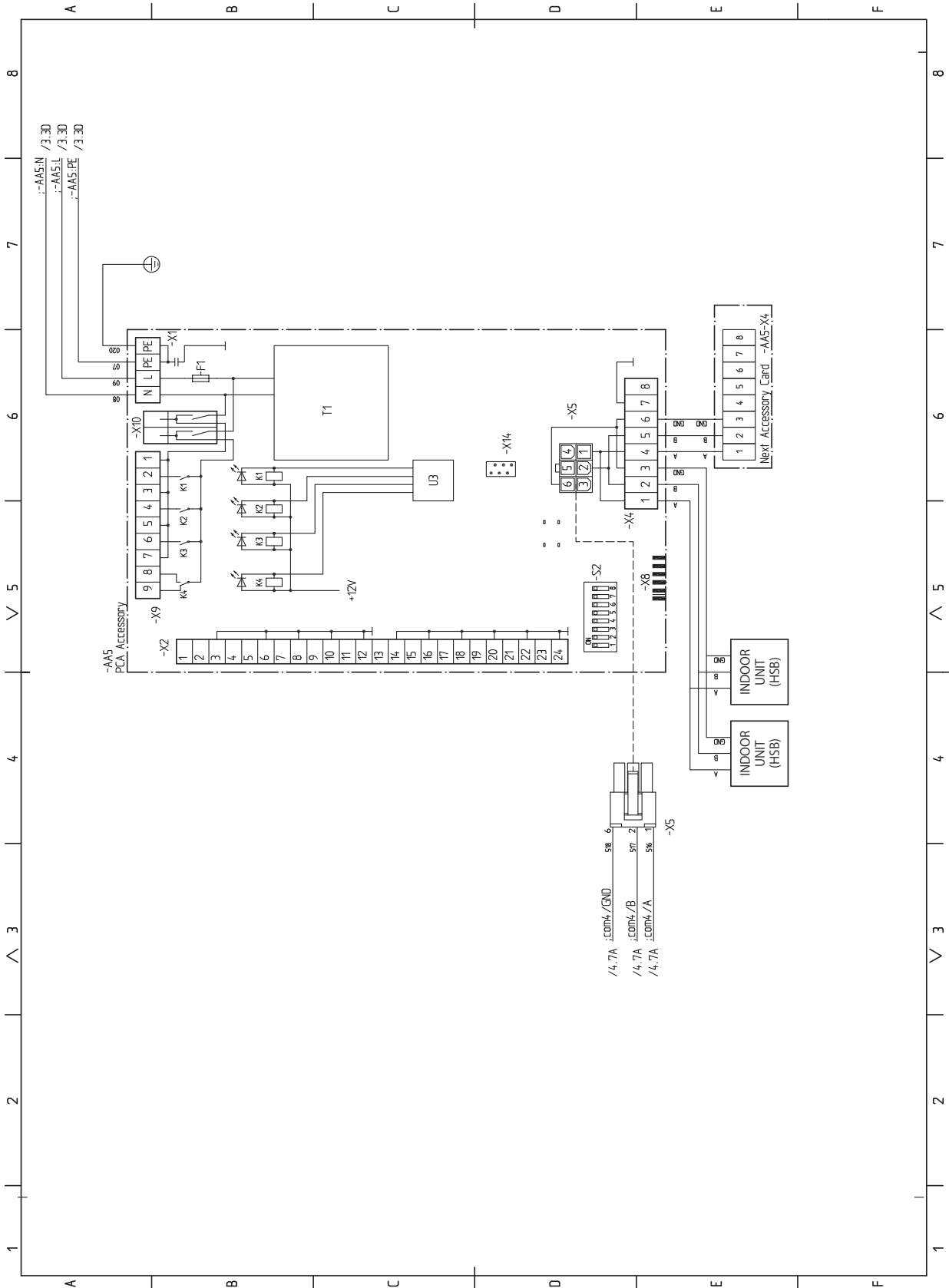

RC-HY40-W- sheet 6

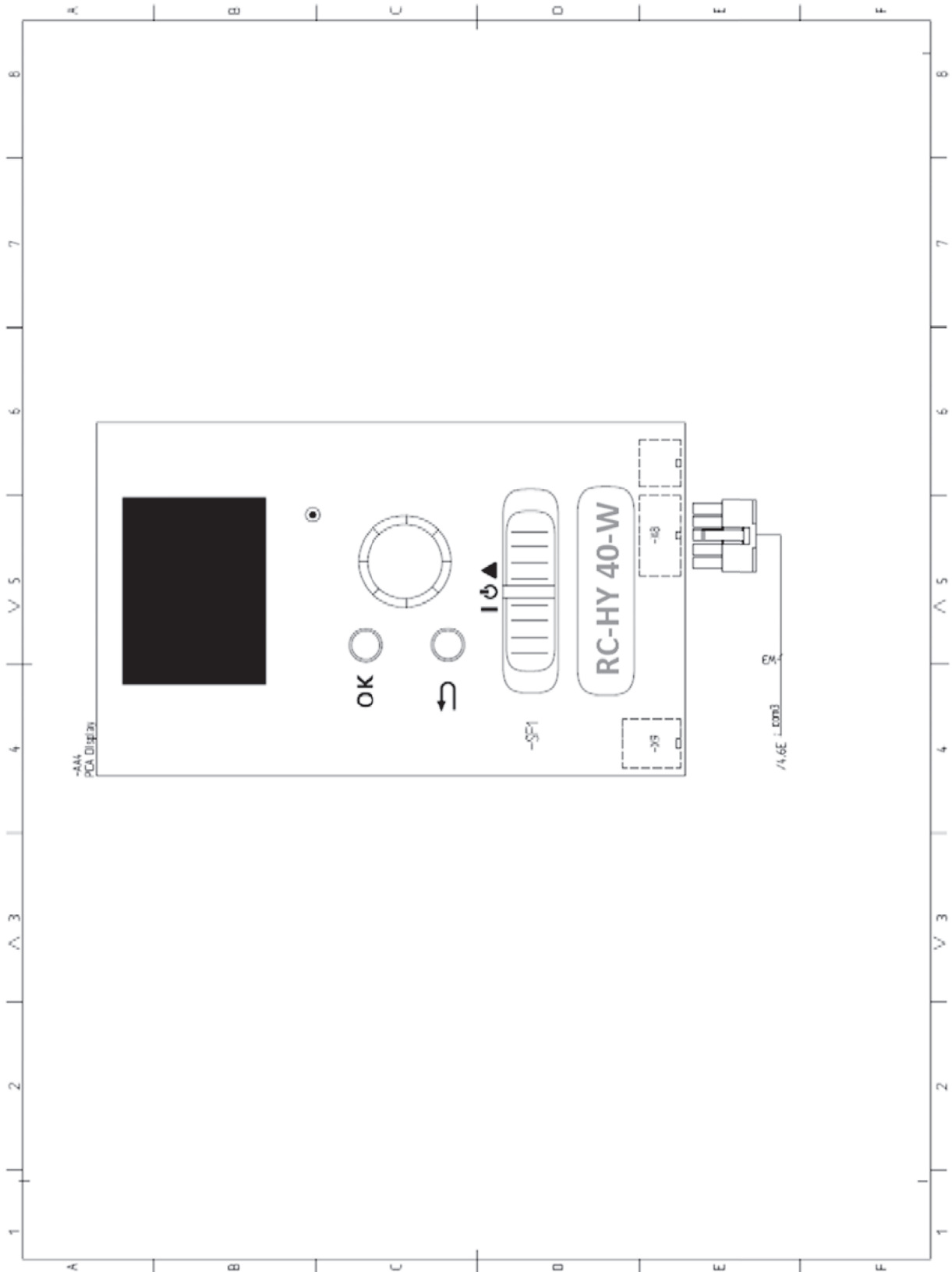

# Installation

# Outdoor unit installation

FDCW60VNX-W

PSC012D134

60VNX

Designed for R32 refrigerant

- ⓘ This installation manual deals with outdoor units and general installation specifications only. For indoor units, refer to the respective installation manuals supplied with the units.
- ⓘ Read this manual carefully before you set to installation work and carry it out according to the instructions contained in this manual.

## SAFETY PRECAUTIONS

- We recommend you to read this "SAFETY PRECAUTIONS" carefully before the installation work in order to gain full advantage of the functions of the unit and to avoid malfunction due to mishandling.
- The precautions described below are divided into [⚠️ WARNING] and [⚠️ CAUTION]. The matters with possibilities leading to serious consequences such as death or serious personal injury due to erroneous handling are listed in the [⚠️ WARNING] and the matters with possibilities leading to personal injury or damage of the unit due to erroneous handling including probability leading to serious consequences in some cases are listed in [⚠️ CAUTION]. These are very important precautions for safety. Be sure to observe all of them without fail.
- The meaning of "Marks" used here are as shown below.
  - ⓘ Never do it under any circumstance.
  - ⓘ Always do it according to the instruction
- Be sure to confirm no anomaly on the equipment by commissioning after completed installation and explain the operating methods as well as the maintenance methods of this equipment to the user according to the owner's manual. If unusual noise can be heard during the test run, consult the dealer.
- Keep the installation manual together with owner's manual at a place where any user can read at any time. Moreover if necessary, ask to hand them to a new user.
- Our company does not assume any responsibility for the damage caused by use of our products without following the instructions mentioned in our manuals.

## WARNING

- ⓘ **Installation must be carried out by the qualified installer.**  
If you install the system by yourself, it may cause serious trouble such as water leaks, electric shocks, fire and personal injury, as a result of a system malfunction.
- ⓘ **Install the system in full accordance with the instruction manual.**  
Incorrect installation may cause bursts, personal injury, water leaks, electric shocks and fire.
- ⓘ **Be sure to wear protective goggles and gloves while performing installation work.**  
Improper safety measures can result in personal injury.
- ⓘ **Use the original accessories and the specified components for installation.**  
If parts other than those prescribed by us are used, it may cause fall of the unit, water leaks, electric shocks, fire, refrigerant leak, substandard performance, control failure and personal injury.
- ⓘ **When installing in small rooms, take prevention measures not to exceed the density limit of refrigerant in the event of leakage accordance with 1505149.**  
Consult the expert about prevention measures. If the density of refrigerant exceeds the limit in the event of leakage, lack of oxygen can occur, which can cause serious accidents.
- ⓘ **Ventilate the working area well in the event of refrigerant leakage during installation.**  
If the refrigerant comes into contact with naked flames, poisonous gas is produced.
- ⓘ **After completed installation, check that no refrigerant leaks from the system.**  
If refrigerant leaks into the room and comes into contact with an oven or other hot surface, poisonous gas is produced.
- ⓘ **Hang up the unit at the specified points with ropes which can support the weight in lifting for portage. And to avoid jolting out of alignment, be sure to hang up the unit at 4-point support.**  
An improper manner of portage such as 3-point support can cause death or serious personal injury due to falling of the unit.
- ⓘ **Install the unit in a location with good support.**  
Unsuitable installation locations can cause the unit to fall and cause material damage and personal injury.
- ⓘ **Ensure the unit is stable when installed, so that it can withstand earthquakes and strong winds.**  
Unsuitable installation locations can cause the unit to fall and cause material damage and personal injury.
- ⓘ **The electrical installation must be carried out by the qualified electrician in accordance with "the norm for electrical work" and "national wiring regulation", and the system must be connected to the dedicated circuit.**  
Power source with insufficient capacity and incorrect function done by improper work can cause electric shocks and fire.
- ⓘ **Be sure to shut off the power before starting electrical work.**  
Failure to shut off the power can cause electric shocks, unit failure or incorrect function of equipment.
- ⓘ **Be sure to use the cables conformed to safety standard and cable ampacity for power distribution work.**  
Unconformable cables can cause electric leak, anomalous heat production or fire.
- ⓘ **Use the prescribed cables for electrical connection, tighten the cables securely in terminal block and relieve the cables correctly to prevent overloading the terminal blocks.**  
Loose connections or cable mountings can cause anomalous heat production or fire.
- ⓘ **Arrange the wiring in the control box so that it cannot be pushed up further into the box. Install the service panel correctly.**  
Incorrect installation may result in overheating and fire.
- ⓘ **Do not process, splice or modify the power cable, or share the socket with other power plugs.**  
Improper power cable or power plug can cause fire or electric shock due to poor connection, insufficient insulation or over-current.
- ⓘ **This appliance must be connected to main power source by means of a circuit breaker or switch with a contact separation of at least 3mm.**  
Improper electrical work can cause unit failure or personal injury.
- ⓘ **When plugging this unit, a plug conforming to the norm IEC60884-1 must be used.**  
Using improper plug can cause electric shock or fire.
- ⓘ **Do not perform brazing work in the airtight room.**  
It can cause lack of oxygen.
- ⓘ **Use the prescribed pipes, flare nuts and tools for R32 or R410A.**  
Using existing parts for R22 or R407C can cause the unit failure and serious accidents due to burst of the refrigerant circuit.
- ⓘ **Tighten the flare nut by using double spanners and torque wrench according to prescribed method. Be sure not to tighten the flare nut too much.**  
Loose flare connection or damage on the flare part by tightening with excess torque can cause burst or refrigerant leaks which may result in lack of oxygen.
- ⓘ **Do not open the service valves for liquid line and gas line until completed refrigerant piping work, air tightness test and evacuation.**  
If the compressor is operated in state of opening service valves before completed connection of refrigerant piping work, you may incur frost bite or injury from an abrupt refrigerant outflow and air can be sucked into refrigerant circuit, which can cause burst or personal injury due to anomalously high pressure in the refrigerant.
- ⓘ **Only use prescribed option parts. The installation must be carried out by the qualified installer.**  
If you install the system by yourself, it can cause serious trouble such as water leaks, electric shocks, fire.
- ⓘ **Do not perform any change of protective device itself or its setup condition.**  
The forced operation by short-circuiting protective device of pressure switch and temperature controller or the use of non specified component can cause fire or burst.
- ⓘ **Be sure to switch off the power source in the event of installation, inspection or servicing.**  
If the power source is not shut off, there is a risk of electric shocks, unit failure or personal injury due to the unexpected start of fan.
- ⓘ **Consult the dealer or an expert regarding removal of the unit.**  
Incorrect installation can cause water leaks, electric shocks or fire.
- ⓘ **Stop the compressor before closing valve and disconnecting refrigerant pipes in case of pump down operation.**  
If disconnecting refrigerant pipes in state of opening service valves before compressor stopping, you may incur frost bite or injury from an abrupt refrigerant outflow and air can be sucked, which can cause burst or personal injury due to anomalously high pressure in the refrigerant circuit.
- ⓘ **Ensure that no air enters in the refrigerant circuit when the unit is installed and removed.**  
If air enters in the refrigerant circuit, the pressure in the refrigerant circuit becomes too high, which can cause burst and personal injury.
- ⓘ **Do not run the unit with removed panels or protections.**  
Touching rotating equipments, hot surfaces or high voltage parts can cause personal injury due to entrapment, burn or electric shocks.
- ⓘ **Be sure to fix up the service panels.**  
Incorrect fixing can cause electric shocks or fire due to intrusion of dust or water.
- ⓘ **Do not perform any repairs or modifications by yourself. Consult the dealer if the unit requires repair.**  
If you repair or modify the unit, it can cause water leaks, electric shocks or fire.
- ⓘ **Do not use any other refrigerant except the HFC-refrigerant (R32).**  
It may cause the serious trouble like malfunction or explosion.
- ⓘ **Do not vent R32 into atmosphere.**  
R32 is a fluorinated greenhouse gas with a Global Warming Potential(GWP)=675.
- ⓘ **Do not bundle or wind or process the power cord. Do not deform the power cord by treading it.**  
This may cause fire or heating.

## CAUTION

- ⓘ **Carry out the electrical work for ground lead with care.**  
Do not connect the ground lead to the gas line, water line, lightning conductor or telephone line's ground lead. Incorrect grounding can cause unit faults such as electric shocks due to short-circuiting. Never connect the grounding wire to a gas pipe because if gas leaks, it could cause explosion or ignition.
- ⓘ **Use the circuit breaker for all pole with correct capacity.**  
Using the incorrect circuit breaker, it can cause the unit malfunction and fire.
- ⓘ **Install isolator or disconnect switch on the power source wiring in accordance with the local codes and regulations.**  
The isolator should be locked in accordance with EN60204-1.
- ⓘ **Take care when carrying the unit by hand.**  
If the unit weighs more than 20kg, it must be carried by two or more persons. Do not carry by the plastic straps, always use the carry handle when carrying the unit by hand. Use gloves to minimize the risk of cuts by the aluminum fins.
- ⓘ **Dispose of any packing materials correctly.**  
Any remaining packing materials can cause personal injury as it contains nails and wood. And to avoid danger of suffocation, be sure to keep the plastic wrapper away from children and dispose of it after tear it up.
- ⓘ **Pay attention not to damage the drain pan by weld spatter when welding work is done near the indoor unit.**  
If weld spatter entered into the indoor unit during welding work, it can cause pin-hole in drain pan and result in water leakage. To prevent such damage, keep the indoor unit in its packing or cover it.
- ⓘ **Be sure to insulate the refrigerant pipes so as not to condense the ambient air moisture on them.**  
Insufficient insulation can cause condensation, which can lead to moisture damage on the ceiling, floor, furniture and any other valuables.
- ⓘ **Be sure to perform air tightness test by pressurizing with nitrogen gas after completed refrigerant piping work.**  
If the density of refrigerant exceeds the limit in the event of refrigerant leakage in the small room, lack of oxygen can occur, which can cause serious accidents.
- ⓘ **Perform installation work properly according to this installation manual.**  
Improper installation can cause abnormal vibrations or increased noise generation.
- ⓘ **After maintenance, all wiring, wiring ties and the like, should be returned to their original state and wiring route, and the necessary clearance from all metal parts should be secured.**
- ⓘ **Earth leakage breaker of appropriate capacity must be installed.**  
If the earth leakage breaker of appropriate capacity is not installed, it can cause fire or electric shocks.
- ⓘ **Do not use any materials other than a fuse with the correct rating in the location where fuses are to be used.**  
Connecting the circuit with copper wire or other metal thread can cause unit failure and fire.
- ⓘ **Do not install the unit near the location where leakage of combustible gases can occur.**  
If leaked gases accumulate around the unit, it can cause fire.
- ⓘ **Do not install the unit where corrosive gas (such as sulfuric acid gas etc.) or combustible gas (such as thinner and petroleum gases) can accumulate or collect, or where volatile combustible substances are handled.**  
Corrosive gas can cause corrosion of heat exchanger, breakage of plastic parts and etc. And combustible gas can cause fire.
- ⓘ **Secure a space for installation, inspection and maintenance specified in the manual.**  
Insufficient space can result in accident such as personal injury due to falling from the installation place.
- ⓘ **When the outdoor unit is installed on a roof or a high place, provide permanent ladders and handrails along the access route and fences and handrails around the outdoor unit.**  
If safety facilities are not provided, it can cause personal injury due to falling from the installation place.
- ⓘ **Do not install nor use the system close to the equipment that generates electromagnetic fields or high frequency harmonics.**  
Equipment such as inverters, standby generators, medical high frequency equipments and telecommunication equipments can affect the system, and cause malfunctions and breakdowns. The system can also affect medical equipment and telecommunication equipment, and obstruct its function or cause jamming.
- ⓘ **Do not install the outdoor unit in a location where insects and small animals can inhabit.**  
Insects and small animals can enter the electric parts and cause damage or fire. Instruct the user to keep the surroundings clean.
- ⓘ **Do not use the base flame for outdoor unit which is corroded or damaged due to long periods of operation.**  
Using an old and damaged base flame can cause the unit falling down and cause personal injury.
- ⓘ **Do not install the unit in the locations listed below**
  - Locations where carbon fiber, metal powder or any powder is floating.
  - Locations where any substances that can affect the unit such as sulphide gas, chloride gas, acid and alkaline can occur.
  - Vehicles and ships
  - Locations where cosmetic or special sprays are often used.
  - Locations with direct exposure of oil mist and steam such as kitchen and machine plant.
  - Locations where any machines which generate high frequency harmonics are used.
  - Locations with salty atmospheres such as coastlines.
  - Locations with heavy snow (If installed, be sure to provide base flame and snow hood mentioned in the manual)
  - Locations where the unit is exposed to chimney smoke.
  - Locations at high altitude (more than 1000m high)
  - Locations with ammoniac atmospheres (e.g. organic fertilizer)
  - Locations with calcium chloride (e.g. snow melting agent)
  - Locations where heat radiation from other heat source can affect the unit.
  - Locations without good air circulation.
  - Locations with any obstacles which can prevent inlet and outlet air of the unit.
  - Locations where short circuit of air can occur (in case of multiple units installation)
  - Locations where strong air blows against the air outlet of outdoor unit.
  - Location where something located above the unit could fall.
 It can cause remarkable decrease in performance, corrosion and damage of components, malfunction and fire.
- ⓘ **Do not install the outdoor unit in the locations listed below.**
  - Locations where discharged hot air or operating sound of the outdoor unit can bother neighborhood.
  - Locations where outlet air of the outdoor unit blows directly to an animal or plants. The outlet air can affect adversely to the plant etc.
  - Locations where vibration or operation sound generated by the outdoor unit can affect seriously, (on the wall or at the place near bed room)
  - Locations where an equipment affected by high harmonics is placed. (TV set or radio receiver is placed within 5m)
  - Locations where drainage cannot run off safely.
 It can affect surrounding environment and cause a claim.
- ⓘ **Do not use the unit for special purposes such as storing foods, cooling precision instruments and preservation of animals, plants or art.**  
It can cause the damage of the items.
- ⓘ **Do not touch any buttons with wet hands.**  
It can cause electric shocks.
- ⓘ **Do not touch any refrigerant pipes with your hands when the system is in operation.**  
During operation the refrigerant pipes become extremely hot or extremely cold depending the operating condition, and it can cause burn injury or frost injury.
- ⓘ **Do not clean up the unit with water.**  
It can cause electric shocks.
- ⓘ **Do not operate the outdoor unit with any article placed on it.**  
You may incur property damage or personal injury from a fall of the article.
- ⓘ **Do not step onto the outdoor unit.**  
You may incur injury from a drop or fall.
- ⓘ **Do not put anything on the outdoor unit.**  
Object may fall causing property damage or personal injury.
- ⓘ **Do not touch the aluminum fin of the outdoor unit.**  
Aluminum fin temperature is high during heating operation. Touching fin can cause burn.

1. TOOLS

Locally procured parts		Tools for installation work		
(a) Anchor bolt(M10-M12)×4 pcs	Plus headed driver	Spanner wrench	Vacuum pump*	
(b) Putty	Knife	Torque wrench [14.0-62.0N/m(1.4-6.2kgf·m)]	Gauge manifold *	
(c) Electrical tape	Saw	Wrench key (Hexagon) [4mm]	Charge hose *	
(d) Connecting pipe	Tape measure	Flaring tool set *	Vacuum pump adapter* (Anti-reverse flow type)	
(e) Connecting cable	Pipe cutter	Flare adjustment gauge	Gas leak detector *	
(f) Power cable				
(g) Clamp and screw (for finishing work)				*Designed specifically for R32 or R410A

2. OUTDOOR UNIT INSTALLATION

Note as a unit designed for R32

- Do not use any refrigerant other than R32. R32 will rise to pressure about 1.6 times higher than that of a conventional refrigerant (R22 or R407C). A cylinder containing R32 has a light blue indication mark on the top.
- In charging refrigerant, always take it out from a cylinder in the liquid phase.
- All indoor units must be models designed exclusively for R32. Check connectable indoor unit models in a catalog, etc. (A wrong indoor unit, if connected into the system, will impair proper system operation)

1. Haulage

- Always carry or move the unit with two or more persons.
- The right hand side of the unit as viewed from the front (outlet side) is heavier.
- A person carrying the right hand side must take care of this fact. A person carrying the left hand side must hold the handle provided on the front panel of the unit with his right hand and the corner column section of the unit with his left hand.

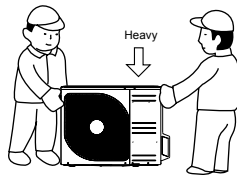

CAUTION

When a unit is hauled, take care of its gravity center position which is shifted towards right hand side. If the unit is not hauled properly, it can go off balance and fall resulting in serious injury.

2. Selecting the installation location

Select the suitable installation location where:

- Unit will be stable, horizontal and free of any vibration transmission.
- There is no obstacle which can prevent smooth air circulation from inlet and outlet side of the unit.
- There is enough space for service and maintenance of unit.
- Neighbours are not bothered by noise or air generating from the unit.
- Outlet air of the unit does not blow directly to animals or plants.
- Drain water can be discharged properly.
- There is no risk of flammable gas leakage.
- There are no other heat sources nearby.
- Unit is not directly exposed to rain or sunlight.
- Unit is not directly exposed to oil mist and steam.
- Chemical substances like ammonia (organic fertilizer), calcium chloride (snow melting agent) and acid (sulfurous acid etc.), which can harm the unit, will not generate or accumulate.
- Unit is not directly exposed to corrosive gases (like sulphide gas, chloride gas), sea breeze or salty atmosphere.
- No TV set or radio receiver is placed within 1m.
- Unit is not affected by electromagnetic waves and/or high-harmonic waves generated by other equipments.
- Strong wind does not blow against the unit outlet.
- Heavy snowfalls do not occur (If installed, provide proper protection to avoid snow accumulation).

NOTE

If the unit is installed in the area where there is a possibility of strong wind or snow accumulation, the following measures are required.

(1) Location of strong wind

- Place the unit with its outlet side facing the wall.
- Place the unit such that the direction of air from the outlet gets perpendicular to the wind direction.



- Use wind guard in case outdoor unit is installed where ambient temperature drops below -10°C and natural wind blows into outdoor unit directly. For details, refer to Technical manual.

(2) Location of snow accumulation

- Install the unit on the base so that the bottom is higher than snow cover surface.
- Install the unit under eaves or provide the roof on site.

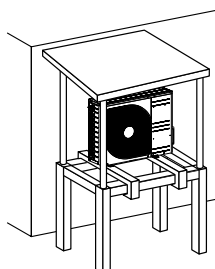

3. Installation space

- There must be 1 meter or larger space between the unit and the wall in at least 1 of the 4 sides. Walls surrounding the unit from 4 sides is not acceptable. The wall height on the outlet side should be 1200 mm or less. Refer to the following figure and table for details.

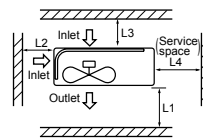

Size	Example installation			
	I	II	III	IV
L1	Open	280	280	180
L2	100	75	Open	Open
L3	100	80	80	80
L4	250	Open	250	Open

NOTE

When more than one unit are installed side by side, provide a 250mm or wider interval between them as a service space.

CAUTION

When more than one unit are installed in parallel directions, provide sufficient inlet space so that short-circuiting may not occur.

4. Drain piping work (If necessary)

Carry out drain piping work if condensed water needs to be drained out.

- Prepare another drain tray made of metallic material for collecting drain when base heater is used.
- Do not use drain elbow and grommet made of plastic for drain piping when base heater for outdoor unit is used. Plastic grommet and elbow will be damaged and burnt in worst case.
- In case plastic grommet and drain elbow is used in warm climate area, disconnect the connector for heater on PCB shown in the drawing.

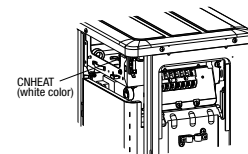
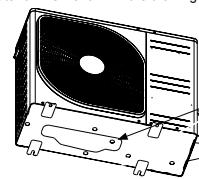

5. Installation

- Install the unit on a flat level base.
- While installing the unit, keep space and fix the unit's legs with 4 anchor bolts as shown in the figure below. The protrusion of an anchor bolt from the foundation surface must be kept within 15mm.

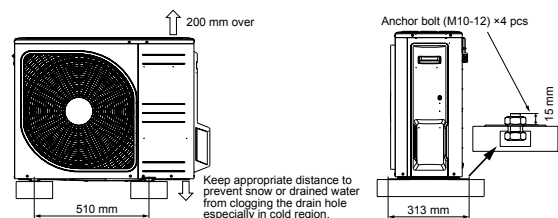

CAUTION

- Install the unit properly so that it does not fall over during earthquake, strong wind, etc.
- Make sure that unit is installed on a flat level base. Installing unit on uneven base may result in unit malfunction.

### 3. PREPARATION FOR WORK

#### 1. Removing service cover

Remove the screw. Slide service cover downwards and remove it.

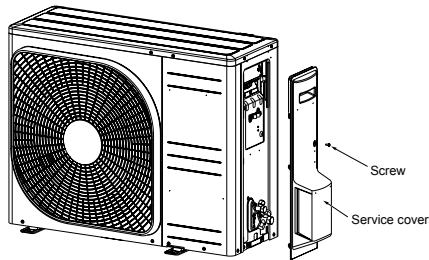

#### 2. Removing terminal cover

Remove the screw and take out terminal cover.

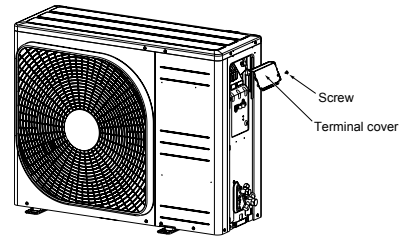

### 4. CONNECTING PIPING WORK

#### 1. Restrictions on unit installation

Abide by the following restrictions on unit installation. Improper installation can cause compressor failure or performance degradation.

	Dimensional restrictions
Connecting pipe length(L)	30m or less
Elevation difference between indoor and outdoor units(H)*	20m or less

\* Outdoor unit installation position can be higher as well as lower than the indoor unit installation position.

#### 2. Preparation of connecting pipe

##### 2.1. Selecting connecting pipe

Select connecting pipe according to the following table.

	Pipe diameter (mm)	Minimum thickness (mm)
Gas pipe	φ12.7	0.8
Liquid pipe	φ6.35	0.8

\* Pipe material must be O-type (Phosphorus deoxidized seamless copper pipe ICS 23.040.15, ICS 77.150.30).

##### 2.2. Cutting connecting pipe

- Cut the connecting pipe to the required length with pipe cutter.
- Hold the pipe downward and remove the burrs. Make sure that no foreign material enters the pipe.
- Cover the connecting pipe ends with the tape.

##### 3. Piping work

Check that both liquid and gas service valves are fully closed. Carry out the piping work with service valves fully closed.

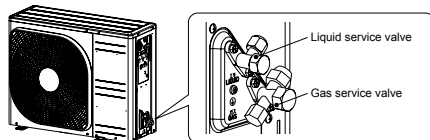

##### 3.1. Flaring pipe

- Take out flare nuts from the service valves of outdoor unit and engage them onto connecting pipes.
- Flare the pipes according to table and figure shown below. Flare dimensions for R32 or R410A are different from those for conventional refrigerant. Although it is recommended to use the flaring tools designed specifically for R32 or R410A, conventional flaring tools can also be used by adjusting the measurement of protrusion B with a flare adjustment gauge.

\* Do not reuse existing flare, make new flare.

Copper pipe outer diameter	A <sub>0-0.4</sub>	Rigid (clutch) type	
		R32 or R410A	Conventional
φ6.35	9.1		
φ9.52	13.2	0-0.5	1.0-1.5
φ12.7	16.6		

##### 3.2. Connecting pipes

- Connect pipes on both liquid and gas sides.
- Tighten nuts to specified torque shown in the table below.

Service valve size (mm)	Tightening torque (N·m)
φ6.35 (1/4")	14-18
φ9.52 (3/8")	34-42
φ12.7 (1/2")	49-61

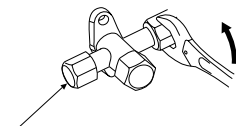

#### CAUTION

- Do not apply refrigerating machine oil to the flared surface. It can cause refrigerant leakage.
- Do not apply excess torque to the flared nuts. The flared nuts may crack resulting in refrigerant leakage.

#### 4. Evacuation

- Connect vacuum pump to gauge manifold. Connect charge hose of gauge manifold to service port of outdoor unit.
- Run the vacuum pump for at least one hour after the vacuum gauge shows -0.1MPa (-76cm Hg).
- Confirm that the vacuum gauge indicator does not rise even if the system is left for 15 minutes or more. Vacuum gauge indicator will rise if the system has moisture left inside or has a leakage point. Check the system for the leakage point. If leakage point is found, repair it and return to (1) again.
- Close the Handle Lo and stop the vacuum pump. Keep this state for a few minutes to make sure that the compound pressure gauge pointer does not swing back.
- Remove valve caps from liquid service valve and gas service valve.
- Turn the liquid service valve's rod 90 degree counterclockwise with a hexagonal wrench key to open valve. Close it after 5 seconds, and check for gas leakage. Using soapy water, check for gas leakage from indoor unit's flare and outdoor unit's flare and valve rods. Wipe off all the water after completing the check.
- Disconnect charging hose from gas service valve's service port and fully open liquid and gas service valves. (Do not attempt to turn valve rod beyond its stop.)
- Tighten service valve caps and service port cap to the specified torque shown in the table below.

Service valve size (mm)	Service valve cap tightening torque (N·m)	Service port cap tightening torque (N·m)
φ6.35 (1/4")	20-30	10-12
φ9.52 (3/8")		
φ12.7 (1/2")	25-35	

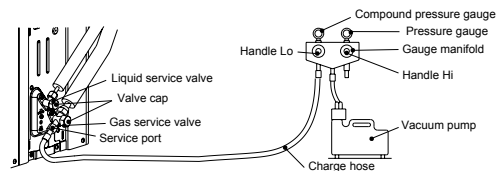

#### CAUTION

- To prevent different oil from entering into the refrigeration system, do not use tools designed for any other refrigerant type.
- To prevent vacuum pump oil from entering into the refrigeration system, use a counterflow prevention adapter.

#### 5. Additional refrigerant charge

Additional refrigerant charge is required only when connecting pipe length exceeds 15 m.

##### 5.1 Calculating additional refrigerant charge

Additional refrigerant charge can be calculated using the formula given below.  
Additional refrigerant charge (g) = { Connecting pipe length (m) - Factory charged length 15 (m) } x 20 (g/m)

#### NOTE

- If additional refrigerant charge calculation result is negative, there is no need to remove the refrigerant.
- If refrigerant recharge is required for the unit with connecting pipe length 15m or shorter, charge the factory charged volume as shown in the table below.

Factory charged volume(kg)	1.30
----------------------------	------

##### 5.2 Charging refrigerant

- Charge the R32 refrigerant in liquid phase from service port with both liquid and gas service valves shut. Since R32 refrigerant must be charged in the liquid phase, make sure that refrigerant is discharged from the cylinder in the liquid phase all the time.
- When it is difficult to charge a required refrigerant volume, fully open both liquid and gas service valves and charge refrigerant, while running the unit in the cooling mode. When refrigerant is charged with the unit being run, complete the charge operation within 30 minutes.
- Write the additional refrigerant charge calculated from the connecting pipe length on the label attached on the service cover.

#### CAUTION

Running the unit with an insufficient quantity of refrigerant for a long time can cause unit malfunction.

### 5. ELECTRICAL WIRING WORK

#### ⚠ WARNING

- Make sure that all the electrical work is carried out in accordance with the national or regional electrical standards.
- Make sure that the earth leakage breaker and circuit breaker of appropriate capacities are installed (Refer to the table given below).
- Do not turn on the power until the electrical work is completed.
- Do not use a condensive capacitor for power factor improvement under any circumstances. (It does not improve power factor. Moreover, it can cause an abnormal overheat accident).

Breaker specifications

Phase	Earth leakage breaker	Circuit breaker
Single phase	Leakage current: 30mA, 0.1sec or less	Over current: 20A

Main fuse specification

Specification	Parts No.	Code on LABEL, WIRING
250V 20A	SSA564A136A	F4

#### 1.Preparing cable

- (1) Selecting cable
  - Select the power source cable and connecting cable in accordance with the specifications mentioned below.
  - (a) Power source cable
    - 3 cores\* 2.0mm<sup>2</sup> or more, conformed with 60245 IEC57
    - When selecting the power source cable length, make sure that voltage drop is less than 2%. If the wire length gets longer, increase the wire diameter.
  - (b) Connecting cable
    - 2 cores\* 1.5mm<sup>2</sup>, conformed with 60245 IEC57
    - \* 1 Earth wire is included (Yellow).
- (2) Arrange each wire length connecting to the outside unit as shown below. Make sure that each wire is stripped 10mm from the end.

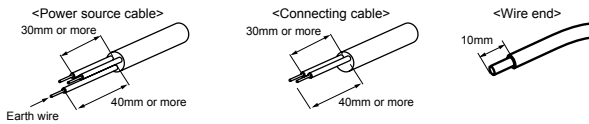

Refer to the installation manual for Indoor unit when arrange each wire connecting to the Indoor unit.

- (3) Attach round crimp-type terminal to each wire connecting to the outside unit as shown in the below. Select the size of round crimp-type terminal after considering the specifications of terminal block and wire diameter.

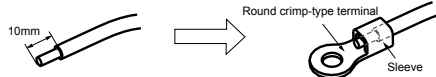

Refer to the installation manual for Indoor unit when arrange each wire connecting to the Indoor unit.

#### ⚠ CAUTION

Power source cable and connecting cable must conform to the specifications mentioned in the manual. Using cables with wrong specifications may result in unit malfunction.

#### 2.Connecting cable

- (1) Remove the service cover.
- (2) Connect the cables according to the instructions and figures given below.
  - (a) Connect the earth wire of power source cable. An earth wire must be connected before connecting the other wires of power source cable. Keep the earth wire longer than the remaining two wires of power source cable.
  - (b) Connect the remaining two wires (N and L) of power source cable.
  - (c) Connect the wires of connecting cable. Make sure that for each wire, outdoor and indoor side terminal numbers match.
- (3) Fasten the cables properly with cable clamps so that no external force may work on terminal connections. Moreover, make sure that cables do not touch the piping, etc. When cables are connected, make sure that all electrical components within the electrical component box are free of loose connector coupling or terminal connection.

<Circuit diagram>

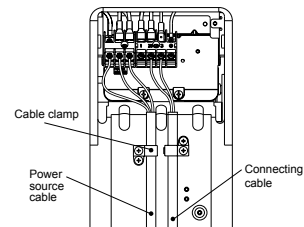
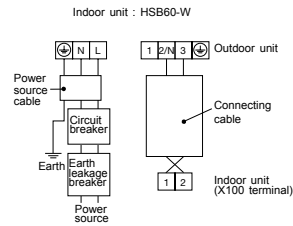

### 6. FINISHING WORK

#### 1. Heating and condensation prevention

- (1) Dress the connecting pipes (both liquid and gas pipes) with insulation to prevent it from heating and dew condensation. Use the heat insulating material which can withstand 120°C or higher temperature. Make sure that insulation is wrapped tightly around the pipes and no gap is left between them.
- (2) Wrap the refrigerant pipings of indoor unit with indoor unit heat insulation using tape.
- (3) Cover the flare-connected joints (indoor side) with the indoor unit heat insulation and wrap it with an insulation pad (standard accessory provided with indoor unit).
- (4) Wrap the connecting pipes, connecting cable and drain hose with the tape.

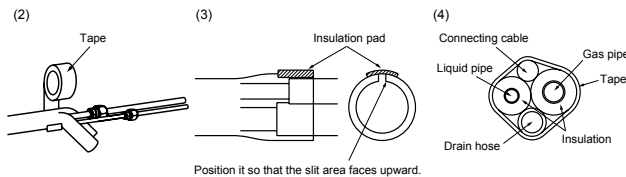

#### NOTE

Locations where relative humidity exceeds 70%, both liquid and gas pipes need to be dressed with 20mm or thicker heat insulation materials.

#### ⚠ CAUTION

- Improper insulation can cause condensate(water) formation during cooling operation. Condensate can leak or drip causing damage to household property.
- Poor heat insulating capacity can cause pipe outer surface to reach high temperature during heating operation. It can cause cable deterioration and personal injury.

#### 2.Finishing work

- (1) Make sure that the exterior portion of connecting pipes, connecting cable and drain hose is wrapped properly with tape. Shape the connecting pipes to match with the contours of the pipe assembly route.
- (2) Fix the pipe assembly with the wall using clamps and screws. Pipe assembly should be anchored every 1.5m or less to isolate the vibration.
- (3) Install the service cover securely. Water may enter the unit if service cover is not installed properly, resulting in unit malfunction and failure.

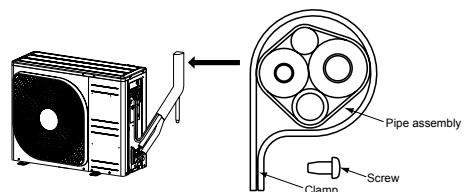

#### ⚠ CAUTION

Make sure that the connecting pipes do not touch the components within the unit. If pipes touch the internal components, it may generate abnormal sounds and/or vibrations.

### 7. INSTALLATION TEST CHECK POINTS

After finishing the installation work, check the following points again before turning on the power. Conduct test run (Refer to indoor unit installation manual) and ensure that the unit operates properly.

Power source voltage complies with the rated voltage of air-conditioner.	No gas leaks from the joints of the service valves.
Earth leakage breaker and circuit breaker are installed.	Indoor and outdoor side pipe joints have been insulated.
Power cable and connecting cable are securely fixed to the terminal block.	Drain hose (if installed) is fixed properly.
Both liquid and gas service valves are fully open.	Screw of the service cover is tightened properly.

### 8. PUMP DOWN (IN CASE OF RELOCATION OR DISPOSAL OF UNIT)

- (1) Connect charge hose of gauge manifold to service port of outdoor unit.
- (2) Close the liquid service valve with hexagonal wrench key.
- (3) Fully open the gas service valve with hexagonal wrench key.
- (4) Carry out pump down operation (For pump down operation procedure, refer to indoor unit installation manual).
- (5) (a) When the low pressure gauge becomes 0.01MPa, close the gas service valve and stop pump down operation. (b) When pump down operation is finished automatically, close the gas service valve.

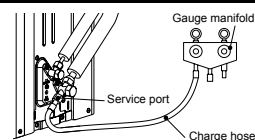







Safety precautions in handling air-conditioners with flammable refrigerants

**R32 REFRIGERANT USED**

**PSA012B839D**

	This equipment uses flammable refrigerants. If the refrigerant is leaked, together with an external ignition source, there is a possibility of ignition.		There is information included in the user's manual and/or installation manual.
	The user's manual should be read carefully.		A service personnel should be handling this equipment with reference to the installation manual.

- This safety precaution sheet is for R32 refrigerant. If you want to know the type of refrigerant in the unit, check the label attached to the outdoor unit.
- The precautionary items mentioned below are distinguished into two levels, **WARNING** and **CAUTION**.

**WARNING** : Wrong installation would cause serious consequences such as injuries or death.

**CAUTION** : Wrong installation might cause serious consequences depending on circumstances.

**WARNING**

- Strict compliance of the domestic laws must be observed when disposing the appliance.
- Do not use means to accelerate the defrosting process or to clean, other than those recommended by the manufacturer.
- The appliance shall be stored in a room without continuously operating ignition sources (for example: open flames, an operating gas appliance or an operating electric heater).
- Do not pierce or burn.
- Be aware that refrigerants may not contain an odour.

**CAUTION**

1. General

- The installation of pipe-work shall be kept to a minimum.
- Pipe-work shall be protected from physical damage.
- Compliance with national gas regulations shall be observed.
- Mechanical connections shall be accessible for maintenance purposes.
- Keep any required ventilation openings clear of obstruction.
- Servicing shall be performed only as recommended by the manufacturer.
- Equipment piping in the occupied space shall be installed in such a way to protect against accidental damage in operation and service.
- Precautions shall be taken to avoid excessive vibration or pulsation to refrigerating piping.
- Protection devices, piping and fitting shall be protected as far as possible against adverse effects for example, the danger of water collection and freezing in relief pipes or the accumulation of dirt and debris.
- Provision shall be made for expansion and contraction of long runs of piping.
- Piping in refrigerating systems shall be designed and installed to minimize the likelihood hydraulic shock damaging the system.
- The indoor equipment and pipes shall be securely mounted and guarded to avoid accidental rupture of equipment from moving furniture or reconstruction activities.

2. Unventilated areas

- The appliance shall be stored in a well-ventilated area where the room size corresponds to the room area as specified for operation.

3. Qualification of workers

- The staff in servicing operations must hold the national qualification or other relevant qualifications.

4. Information on servicing

- 4.1 Checks to the area
  - Prior to beginning work on systems containing flammable refrigerants, safety checks are necessary to ensure that the risk of ignition is minimised.
  - For repair to the refrigerating system, 4.2 to 4.6 shall be completed prior to conducting work on the system.
- 4.2 Work procedure
  - Work shall be undertaken under a controlled procedure so as to minimise the risk of a flammable gas or vapour being present while the work is being performed.

4.3 General work area

- All maintenance staff and others working in the local area shall be instructed on the nature of work being carried out.
- Work in confined spaces shall be avoided.

4.4 Checking for presence of refrigerant

- The area shall be checked with an appropriate refrigerant detector prior to and during work, to ensure the technician is aware of potentially toxic or flammable atmospheres.
- Ensure that the leak detection equipment being used is suitable for use with all applicable refrigerants, i.e. non-sparking, adequately sealed or intrinsically safe.

4.5 Presence of fire extinguisher

- If any hot work is to be conducted on the refrigerating equipment or any associated parts, appropriate fire extinguishing equipment shall be available to hand. Have a dry powder or CO<sub>2</sub> fire extinguisher adjacent to the charging area.

4.6 No ignition sources

- No person carrying out work in relation to a refrigerating system which involves exposing any pipe work shall use any sources of ignition such a manner that it may lead to the risk of fire or explosion.
- All possible ignition sources, including cigarette smoking, should be kept sufficiently far away from the site of installation, repairing, removing and disposal, during which refrigerant can possibly be released to the surrounding space.
- Prior to work taking place, the area around the equipment is to be surveyed to make sure that there are no flammable hazards or ignition risks.
- "No Smoking" signs shall be displayed.

4.7 Ventilated area

- Ensure that the area is in the open or that it is adequately ventilated before breaking into the system or conducting any hot work.
- A degree of ventilation shall continue during the period that the work is carried out.
- The ventilation should safely disperse any released refrigerant and preferably expel it externally into the atmosphere.

4.8 Checks to the refrigerating equipment

- Where electrical components are being changed, they shall be fit for the purpose and to the correct specification.
- At all times the manufacturer's maintenance and service guidelines shall be followed.
- If in doubt consult the manufacturer's technical department for assistance.

The following checks shall be applied to installations using flammable refrigerants:

- the actual refrigerant charge size is in accordance with the room size within which the refrigerant containing parts are installed.
- the ventilation machinery and outlets are operating adequately and are not obstructed;
- if an indirect refrigerating circuit is being used, the secondary circuit shall be checked for the presence of refrigerant,
- marking of the equipment continues to the visible and legible. Markings and signs that are illegible shall be corrected,
- refrigerating pipe or components are installed in a position where they are unlikely to be exposed to any substance which may corrode refrigerant containing components, unless the components are constructed of materials which are inherently resistant to being corroded or are suitably protected against being so corroded.

4.9 Checks to electrical devices

- Repair and maintenance to electrical components shall include initial safety checks and component inspection procedures.
- If a fault exists that could compromise safety, then no electrical supply shall be connected to the circuit until it is satisfactorily dealt with.
- If the fault cannot be corrected immediately but it is necessary to continue operation, an adequate temporary solution shall be used.
- This shall be reported to the owner of the equipment so all parties are advised.
- Initial safety checks shall include:
  - that capacitors are discharged: this shall be done in a safe manner to avoid possibility of sparking;
  - that no live electrical components and wiring are exposed while changing, recovering or purging the system.
  - that there is continuity of earth bonding.

5. Repairs to sealed components

- During repairs to sealed components, all electrical supplies shall be disconnected from the equipment being worked upon prior to any removal of sealed covers, etc.
- If it is absolutely necessary to have an electrical supply to equipment during servicing then a permanently operating from of leak detection shall be located at the most critical point to warn of a potentially hazardous situation.
- Particular attention shall be paid to the following to ensure that by working on electrical components, the casing is not altered in such a way that the level of protection is affected. This shall include damage to cables, excessive number of connections, terminals not made to original specification, damage to seals, incorrect fitting of glands, etc.

### ⚠ CAUTION

- Ensure that the apparatus is mounted securely.
- Ensure that seals or sealing materials have not degraded to the point that they no longer serve the purpose of preventing the ingress of flammable atmospheres.
- Replacement parts shall be in accordance with the manufacturer's specifications.

#### 6. Repair to intrinsically safe components

- Do not apply any permanent inductive or capacitance loads to the circuit without ensuring that this will not exceed the permissible voltage and current permitted for the equipment in use.
- Intrinsically safe components are the only types that can be worked on while live in the presence of a flammable atmosphere.
- The test apparatus shall be at the correct rating.
- Replace components only with parts specified by the manufacturer.
- Other parts may result in the ignition of refrigerant in the atmosphere from a leak.

#### NOTE

The use of silicone sealant can inhibit the effectiveness of some types of leak detection equipment. Intrinsically safe components do not have to be insulated prior to working on them.

#### 7. Cabling

- Check that cabling will not be subject to wear, corrosion, excessive pressure, vibration, sharp edges or any other adverse environmental effects. The check shall also take into account the effects of aging or continual vibration from sources such as compressors or fans.

#### 8. Detection of flammable refrigerants

- Under no circumstances shall potential sources of ignition be used in the searching for or detection of refrigerant leaks.
- A halide torch (or any other detector using a naked flame) shall not be used.
- Electronic leak detectors may be used to detect refrigerant leaks but, in the case of flammable refrigerants, the sensitivity may not be adequate, or may need re-calibration. (Detection equipment shall be calibrated in a refrigerant-free area.)
- Ensure that the detector is not a potential source of ignition and is suitable for the refrigerant used.
- Leak detection equipment shall be set at a percentage of the LFL of the refrigerant and shall be calibrated to the refrigerant employed, and the appropriate percentage of gas (25 % maximum) is confirmed.
- Leak detection fluids are suitable for use with most refrigerants but the use of detergents containing chlorine shall be avoided as the chlorine may react with the refrigerant and corrode the copper pipe-work.

Examples of leak detection fluids are

- bubble method
- fluorescent method agents

- If a leak is suspected, all naked flames shall be removed/extinguished.
- If a leakage of refrigerant is found which requires brazing, all of the refrigerant shall be recovered from the system, or isolated (by means of shut off valves) in a part of the system remote from the leak.
- Removal of refrigerant shall be according to Item 9.

#### 9. Removal and evacuation

- When breaking into the refrigerant circuit to make repairs - or for any other purpose - conventional procedures shall be used. However, for flammable refrigerants it is important that best practice is followed since flammability is a consideration.
- The following procedure shall be adhered to:
  - remove refrigerant;
  - purge the circuit with inert gas; (optional for A2L)
  - evacuate; (optional for A2L)
  - purge with inert gas; (optional for A2L)
  - open the circuit by cutting or brazing.

- The refrigerant charge shall be recovered into the correct recovery cylinders.
- For appliances containing flammable refrigerants, other than A2L refrigerants, the system shall be "flushed" with OFN to render the unit safe.
- This process may need to be repeated several times.
- Compressed air or oxygen shall not be used for purging refrigerant systems.
- For appliances containing flammable refrigerants, other than A2L refrigerants, refrigerants purging shall be achieved by breaking the vacuum in the system with oxygen-free nitrogen and continuing fill until the working pressure is achieved, then venting to atmosphere, and finally pulling down to a vacuum.
- This process shall be repeated until no refrigerant is within the system.
- When the final oxygen-free nitrogen charge is used, the system shall be vented down to atmospheric pressure to enable work to take place.
- This operation is absolutely vital if brazing operations on the pipe-work are to take place.
- Ensure that the outlet for the vacuum pump is not close to any ignition sources and that ventilation is available.

#### 10. Charging procedures

- In addition to conventional charging procedures, the following requirements shall be followed.
  - Ensure that contamination of different refrigerants does not occur when using charging equipment. Hoses of lines shall be as short as possible to minimise the amount of refrigerant contained in them.
  - Cylinders shall be kept in an appropriate according to the instructions.
  - Ensure that the refrigerating system is earthed prior to charging the system with refrigerant.
  - Label the system when charging is complete (if not already).
  - Extreme care shall be taken not to overfill the refrigerating system.
- Prior to recharging the system, it shall be pressure-tested with the appropriate purging gas.
- The system shall be leak-tested on completion of charging but prior to commissioning.
- A follow up leak test shall be carried out prior to leaving the site.

#### 11. Decommissioning

- Before carrying out this procedure, it is essential that the technician is completely familiar with the equipment and all its detail.
- It is recommended good practice that all refrigerants are recovered safely.
- Prior to the task being carried out, an oil and refrigerant sample shall be taken in case analysis is required prior to re-use of recovered refrigerant.
- It is essential that electrical power is available before the task is commenced.
  - Become familiar with the equipment and its operation.
  - Isolate system electrically.
  - Before attempting the procedure ensure that
    - mechanical handling equipment is available, if required, for handling refrigerant cylinders,
    - all personal protective equipment is available and being used correctly,
    - the recovery process is supervised at all times by a competent person,
    - recovery equipment and cylinders conform to the appropriate standards.
  - Pump down refrigerant system, if possible.
  - If a vacuum is not possible, make a manifold so that refrigerant can be removed from various parts of the system.
  - Make sure that cylinder is situated on the scales before recovery takes place.
  - Start the recovery machine and operate in accordance with instructions.
  - Do not overfill cylinders. (No more than 80 % volume liquid charge).
  - Do not exceed the maximum working pressure of the cylinder, even temporarily.

- j) When the cylinders have been filled correctly and the process completed, make sure that the cylinders and the equipment are removed from site promptly and all isolation valves on the equipment are closed off.
- k) Recovered refrigerant shall not be charged into another refrigerating system unless it has been cleaned and checked.

#### 12. Labelling

- Equipment shall be labelled stating that it has been de-commissioned and emptied of refrigerant. The label shall be dated and signed.
- For appliances containing flammable refrigerants, ensure that there are labels on the equipment stating the equipment contains flammable refrigerant.

#### 13. Recovery

- When removing refrigerant from a system, either for servicing or decommissioning, it is recommended good practice that all refrigerants are removed safely.
- When transferring refrigerant into cylinders, ensure that only appropriate refrigerant recovery cylinders are employed.
- Ensure that the correct number of cylinders for holding the total system charge is available.
- All cylinders to be used are designated for the recovered refrigerant and labelled for that refrigerant (i.e. special cylinders for the recovery of refrigerant).
- Cylinders shall be complete with pressure relief valve and associated shut-off valves in good working order.
- Empty recovery cylinders are evacuated and, if possible, cooled before recovery occurs.
- The recovery equipment shall be in good working order with a set of instructions concerning the equipment that is at hand and shall be suitable for the recovery of all appropriate refrigerants including, when applicable, flammable refrigerants.
- In addition, a set of calibrated weighing scales shall be available and in good working order.
- Hoses shall be complete with leak-free disconnect couplings and in good condition.
- Before using the recovery machine, check that it is in satisfactory working order, has been properly maintained and that any associated electrical components are sealed to prevent ignition in the event of a refrigerant release. Consult manufacturer if in doubt.
- The recovered refrigerant shall be returned to the refrigerant supplier in the correct recovery cylinder, and the relevant Waste Transfer Note arranged. Do not mix refrigerants in recovery units and especially not in cylinders.
- If compressors or compressor oils are to be removed, ensure that they have been evacuated to an acceptable level to make certain that flammable refrigerant dose not remain within the lubricant.
- The evacuation process shall be carried out prior to returning the compressor to the suppliers.
- Only electric heating to the compressor body shall be employed to accelerate this process.
- When oil is drained from a system, it shall be carried out safely.

#### 14. Other safety precautions

- A brazed, welded, or mechanical connection shall be made before opening the valves to permit refrigerant to flow between the refrigerating system parts.
- Flammable refrigerant used, refrigerant tubing protected or enclosed to avoid mechanical damage (IEC/EN 60335-2-40/A1).
- Tubing protected to extent that it will not be handled or used for carrying during moving of product (IEC/EN 60335-2-40/A1).
- Flammable refrigerant used, low temperature solder alloys, such as lead/tin alloys, not acceptable for pipe connections (IEC/EN 60335-2-40/A1).
- Do not use flare nut indoor which is locally procured.

## Indoor unit installation

### General information for installer

For outdoor unit installation information, see installation manual for outdoor unit.

## Over view and design

### HSB60-W

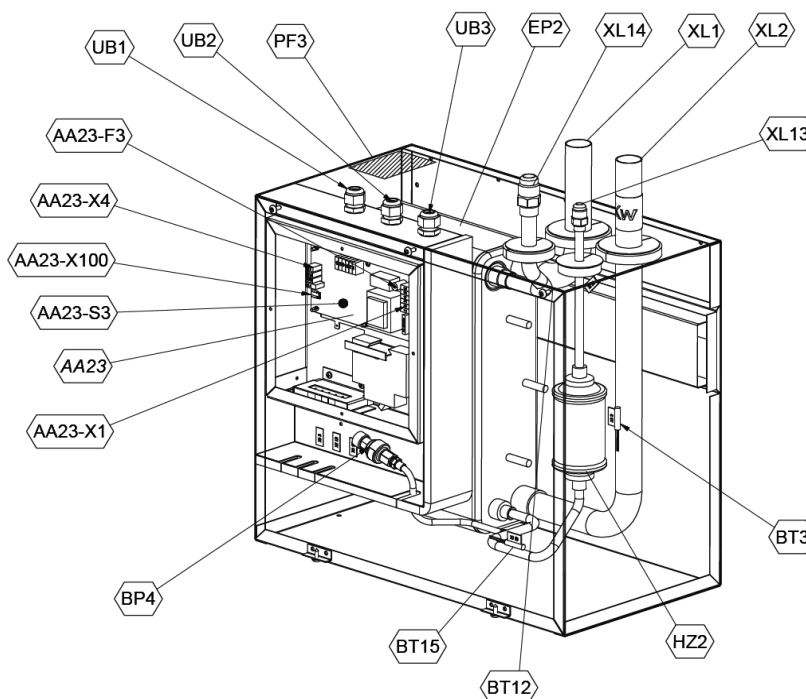

#### Pipe connections

XL1 (Red mark)	Climate system supply
XL2 (Blue mark)	Climate system return
XL14	Connection, gas line
XL13	Connection, liquid line

#### Valves etc.

EP2	Heat exchanger
HQ1	Particle filter (supplied)
HZ2	Drying filter

#### Electrical components

AA23	Communication board
AA23-F3	Fuse for external heating cable
AA23-S3	DIP switch, addressing of outdoor unit
AA23-X1	Terminal block, incoming supply, connection of KVR
AA23-X4	Terminal block, communication with indoor module / control module
AA23-X100	Terminal block, communication outdoor module

#### Sensor, thermostats

BP4	Pressure sensor, high pressure
BT3	Temperature sensor, heating medium, return
BT12	Temperature sensor, condenser, supply
BT15	Temperature sensor, fluid pipe

#### Miscellaneous

UB1	Cable gland
UB2	Cable gland
UB3	Cable gland

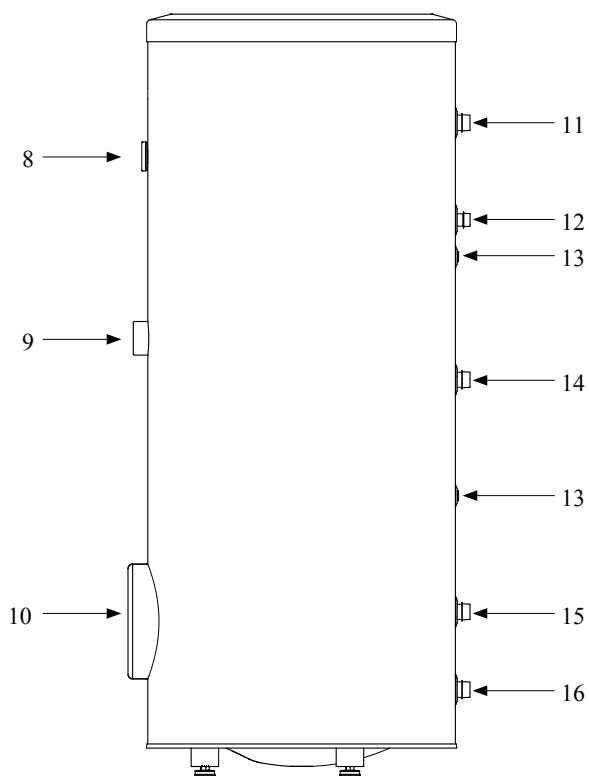
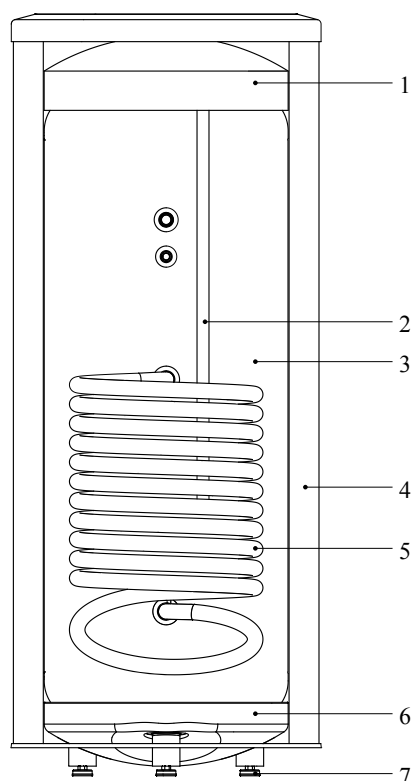
**PT300****Section of the PT300 storage tanks**

1. Upper insulation of the storage tank
2. Protective magnesium anode
3. Enamelled tank
4. Side insulation of the storage tank
5. Coil
6. Lower insulation of the storage tank
7. Adjustable foot

**Side view of the PT300 storage tanks**

8. Thermometer
9. Connector pipe for mounting electric heating unit
10. Inspection opening
11. Hot water intake connector pipe
12. Hot water circulation connector pipe
13. Temperature sensor cover
14. Coil supply connector pipe
15. Connection of return line from the coil
16. Cold water supply connector pipe

## Transport and storage

Indoor unit and tank unit must be transported and stored vertically in dry conditions.

## Supplied components

### HSB60-W Indoor unit

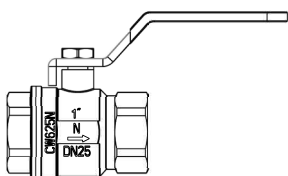

Particle filter R25 (HQ1)

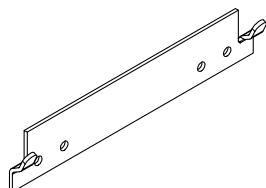

Brackets kit

### RC-HY20/40-W

### Control unit



Outside sensor



Room sensor (RC-HY40-W only)

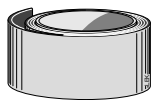

Insulation tape

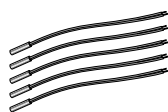

Temperature sensor

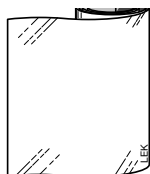

Aluminium tape



Cable ties



Heating pipe paste



Current sensor (RC-HY40-W only)

## Assembly

- It is recommended that indoor unit is installed in a room with existing floor drainage, most suitably in a utility room or boiler room.
- For indoor unit and control unit, the mounting surface must be firm, flat and vertical, preferably a concrete wall.
- Tank unit must be set on a solid waterproof base that would keep the weight of the unit. The height-adjusting legs allow for levelling and stable setting.

### PT300

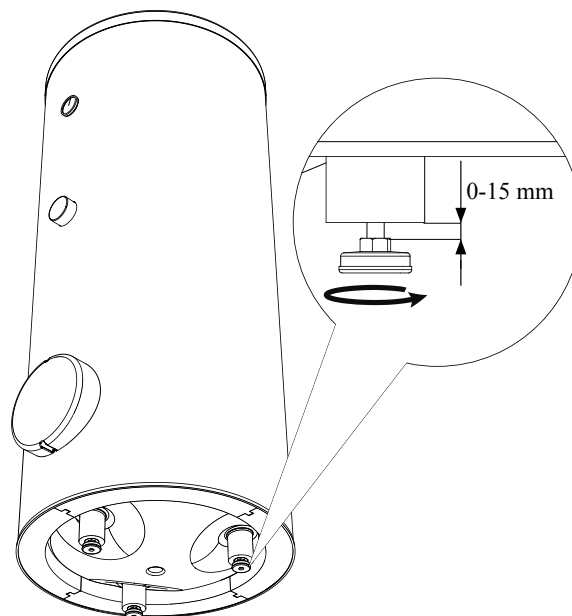

- Install indoor unit with its back to an outside wall, ideally in a room where noise does not matter. If this is not possible, avoid placing it against a wall behind a bedroom or other room where noise may be a problem.
- Route pipes so they are not fixed to an internal wall that backs on to a bedroom or living room.
- Install tank unit and its pipings to indoor unit indoors in order to avoid icing.
- Ensure free space described in the following figures for future maintenance.

**HSB60-W**

Recommendation for positioning on wall

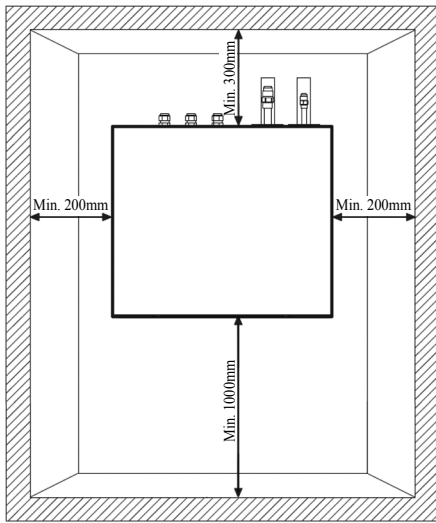

Recommendation for positioning in corner

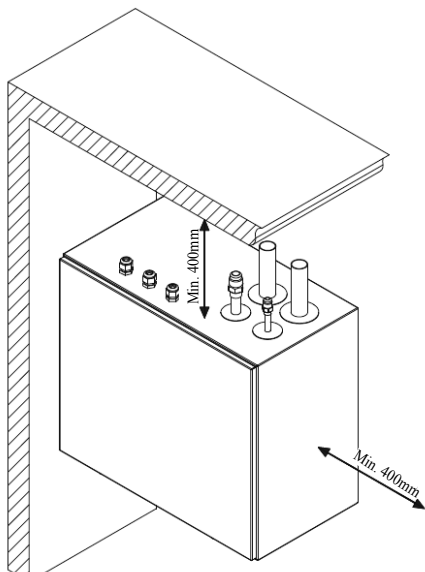

\*Min 800mm is required in front

**PT300**

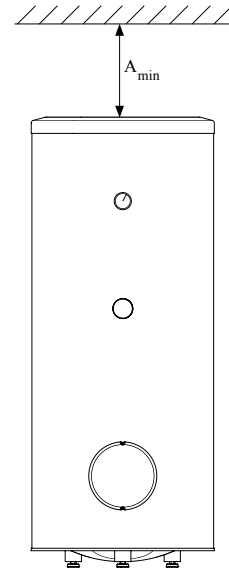

A<sub>min</sub> is required on top to replace anode bar, and 500mm is required in front to replace immersion heater if equipped.

Application	Connector pipe diameter	Type of anode	A <sub>min</sub>
PT300	1"	Chain $\phi 26 \times 8$	150mm
	$\frac{3}{4}$ "	Titanium anode	200mm

**RC-HY20/40-W**

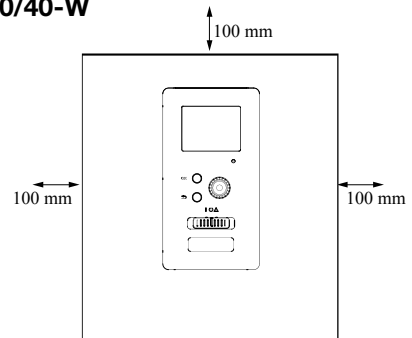

## Hanging indoor unit

It is recommended that the split box is installed in a room with existing floor drainage, most suitably in a utility room or boiler room.

1. The bracket for the split box is mounted to the wall by use of appropriate screws.

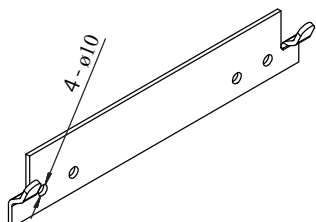

2. Insert HSB60-W in the bracket mounted to the wall.

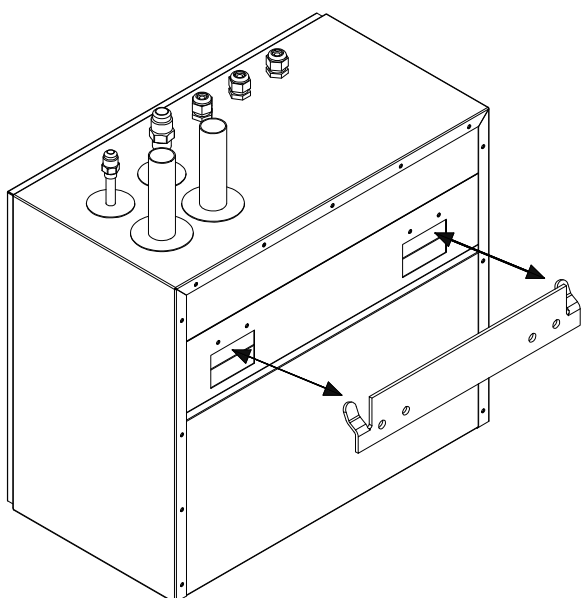

### NOTE

*Indoor unit weight 16kg excluding water inside.*

## Hanging control unit

Use all mounting points and install control unit upright against a flat wall. Make sure whole back surface faces the wall.

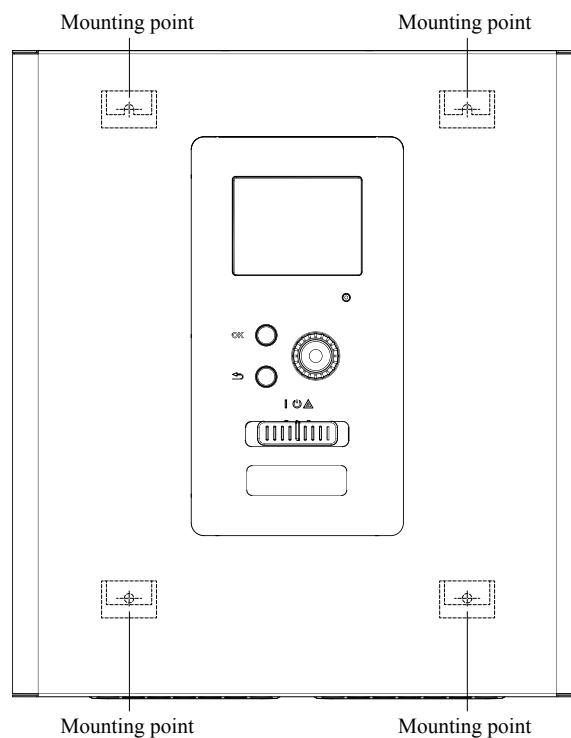

## Dimensioning expansion vessel

The expansion vessel volume must be at least 5% of total water volume in the circulation system.

### Initial pressure and max height difference

Recommended maximum height difference between expansion vessel and the highest point in the system is 5m.

The initial pressure of the pressure expansion vessel must be dimensioned according to the maximum height (H) between the vessel and the highest positioned radiator, see figure. An initial pressure of 0.5bar (5 mvp) means a maximum permitted height difference of 5m.

If the standard initial pressure in the pressure vessel is not high enough it can be increased by filling via the valve in the expansion vessel. The expansion vessel's standard initial pressure must be entered in the check list on User's manual.

Any change in the initial pressure affects the ability of the expansion vessel to handle the expansion of the water.

Consult local distributor in case height difference exceeds 5m.

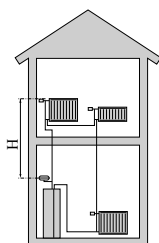

## Recommended installation order

1. Hang indoor unit and control unit to appropriate position and connect indoor unit and tank unit.
2. Connect indoor unit to climate system, cold and hot water lines as well as any external heat sources. See page 47. Also see docking descriptions on page 180.
3. Install refrigerant pipes according to the description on the Installation manual for outdoor unit.
4. Connect current limiter, any centralised load control and external contacts as well as the cable between indoor unit and outdoor unit.
5. Connect incoming electricity to indoor unit and/or outdoor unit. See page 58, 59.
6. Follow the commissioning instructions on page 60-70.



## Pipe installation

### General

Pipe installation must be carried out in accordance with current norms and directives.

A following table shows plumbing necessary for each product.

	Refrigerant	Plumbing
HSB	Necessary	Necessary
PT	–	Necessary
RC-HY	–	–

This heat pump system is designed for low or medium temperature heating system. It is recommended water temperature must not exceed 55°C on supply and 45°C on return at lowest design outdoor temperature (DOT) though

indoor unit can operate with a return temperature of up to 65°C and an outgoing temperature from the unit of 65°C.

Indoor unit is not equipped with shut off valves; these must be installed outside the heat pump to facilitate any future servicing.

Indoor unit can be connected to the radiator system, floor heating system and/or fan convectors.

Safety valve is not equipped with in indoor unit. Make sure to install safety valve in the circuit.

### Installation diagram

Outdoor unit provides heat for space heating and domestic hot water using free energy in the outdoor air within the range of low temperature up to -20°C. The system is controlled by RC-HY20-W or RC-HY40-W control unit.

#### HSB60-W

Indoor unit is equipped with plate heat exchanger. It needs to install expansion vessel, shut-off valves, safety valve, electric heater and circulation pump to make a complete heating system. In case domestic hot water is required, 3-way valve and tank is also necessary.

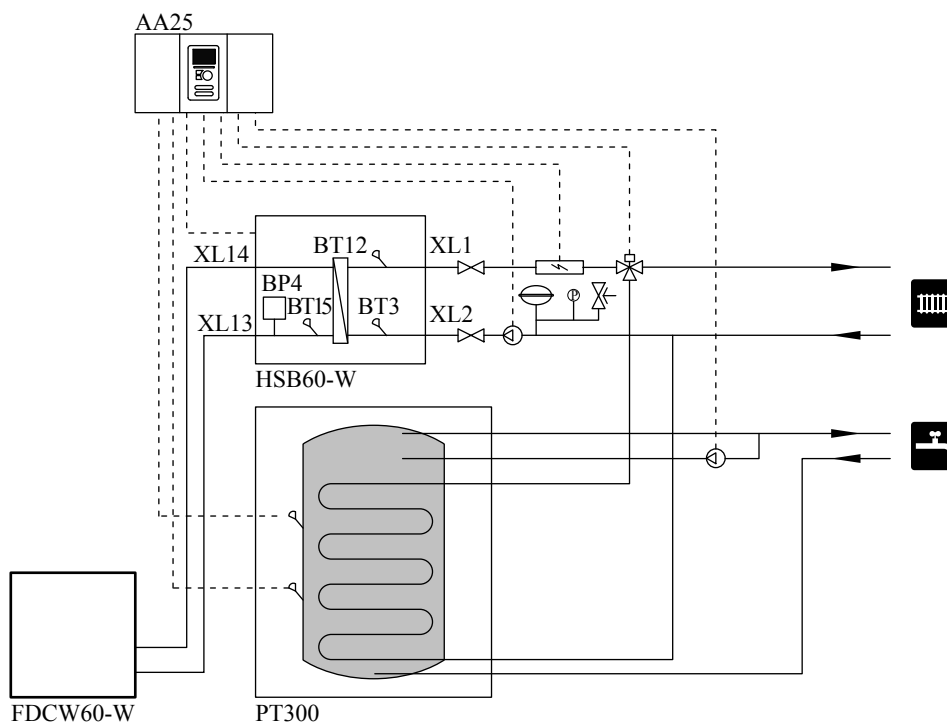

## System requirements

The minimum water volume in the climate system is subject to the values in the table below. If it is not fulfilled, volume vessel must be installed.

(liter)

	With underfloor cooling application	Without underfloor cooling application
HSB60-W, FDCW60VNX-W	50	20

## Overflow valve

### NOTE

*A free flow is required for all docking options, which means that an overflow valve must be installed.*

***The circulation pump may become damaged.***

## Pump capacity diagram

### HSB60-W

HSB60-W is not equipped with circulation pump.

This graph shows the characteristic of CPD11-25M/65.

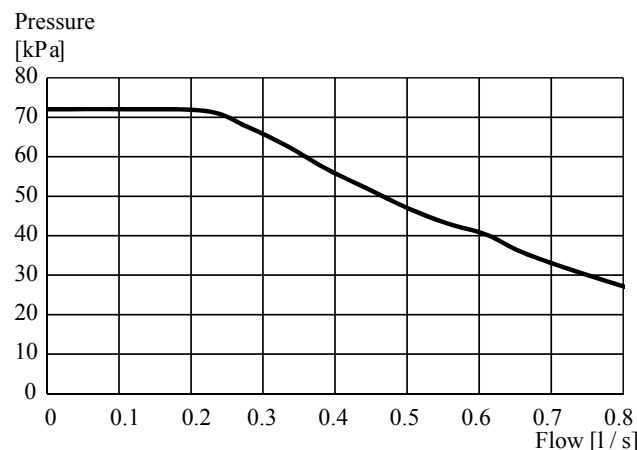

## Pressure drop in indoor unit

### HSB60-W

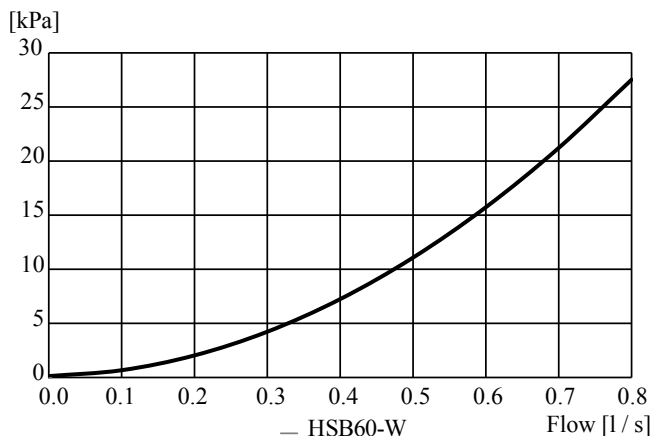

## Connection of extra circulation pump

When connecting extra circulation pumps, requirements for pressure, maximum flow etc must be satisfied.

### NOTE

*Non-return valve must be installed in case extra circulation pump is used.*

***The circulation pump may become damaged.***

**PT300**

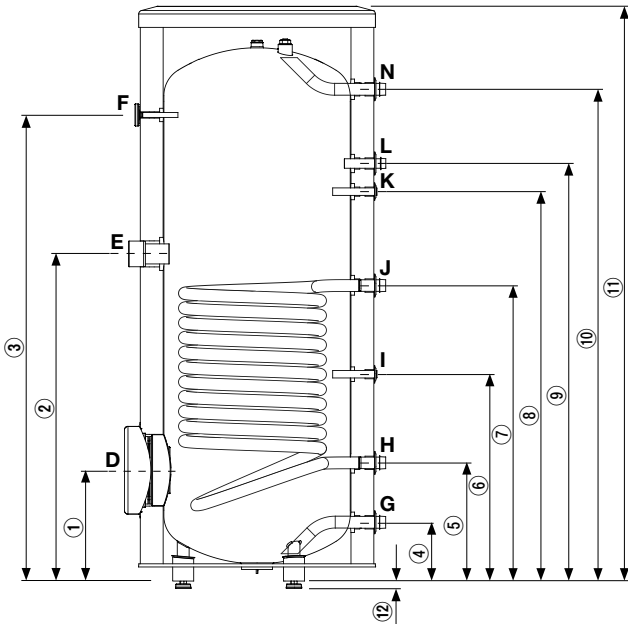

Connection		U/m	PT300
D	Inspection opening	mm	φ 120
E	Heating unit connection	inch	1½" Female
F	Thermometer enclosure	mm	φ 10 Female
N	Hot water outlet	inch	1" Male
L	Hot water circulation	inch	¾" Male
K	Temperature sensor enclosure (BT7)	mm	φ 16 Female
J	Coil supply	inch	1" Male
I	Temperature sensor enclosure (BT6)	mm	φ 16 Female
H	Return from coil	inch	1" Male
G	Cold water input	inch	1" Male

Dimensions		
		PT300
①	mm	315
②	mm	930
③	mm	1325
④	mm	167
⑤	mm	336
⑥	mm	588
⑦	mm	840
⑧	mm	1107
⑨	mm	1187
⑩	mm	1398
⑪	mm	1634
⑫	mm	21-0/+15

## Water circuit

### Connection to heating system

Connect XL1 to supply line and X2 to return line from heating system.

- All required safety devices and shut-off valves must be installed as close to the indoor unit as possible.
- Install bleed valves where necessary, highest point of the water system in usual case.
- When connecting to a system with thermostats on all radiators, install an overflow valve or remove some of the thermostats to ensure sufficient flow.
- Install a safety valve with manometer on heating circuit and hot water circuit. (FL2)

For HSB60-W install a safety valve for heating circuit on the water pipe returning to indoor unit since it doesn't have port for FL2.

The entire length of the overflow water pipe from the safety valves must be inclined to prevent water pockets and must also be frost proof.

- The end of overflow water pipe from the safety valves must be left open to the atmosphere. The water may drip from the pipe.

### Connection to hot water heater

For HSB60 indoor unit, it is necessary to connect PT300 tank unit applying 3-way valve in order to use domestic hot water function.

### Housing disassembly of tank unit

Removable housing with thermal insulation facilitates transport and installation of the storage tank. Disassembly the housing in the following order (see next page figure):

1. Remove the temperature gauge, plug of the heating element connector pipe and blanking plate of the inspection opening.
2. Remove the upper cover of the housing together with thermal insulation.
3. Remove the plugs from the connector pipes and black bushings.
4. Remove the fixing screws and the strip connecting the housing jacket.
5. Remove the jacket surrounding the tank (housing jacket.)
6. Remove the four-piece thermal insulation.

After the installation of the storage tank in its final location, reinstall the removed components in the reverse order.

### HSB60-W

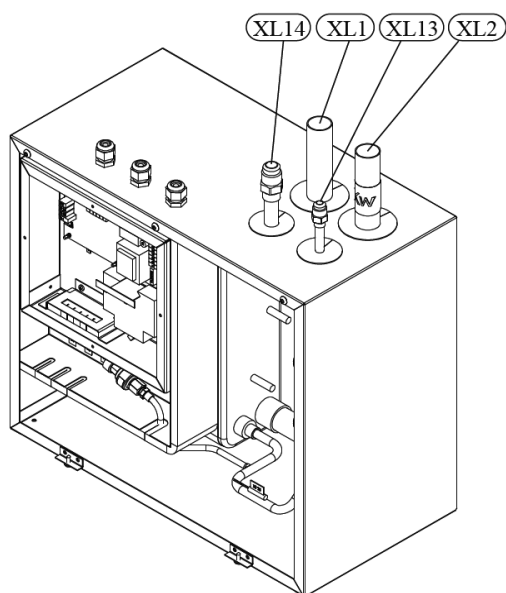

Install safety valve as close to XL2 as possible.

Housing and thermal insulation disassembly

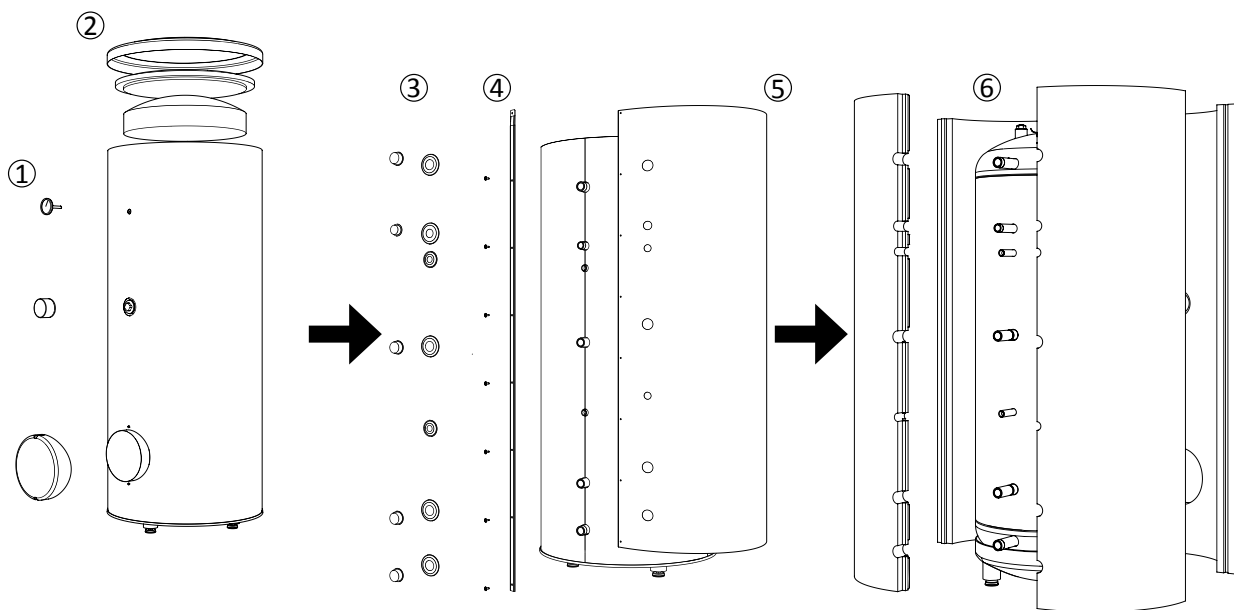

Connecting hot water tank to indoor unit

**CAUTION**

*Installation and commissioning of the storage tank shall only be done by appropriately qualified installer. The installer should inform the user of the functions of the product and provide the necessary information on its safe use.*

**Information**

*We recommend installing a strainer in order to protect the pumps, check valve and the components of the heating system.*

- Tank and its pipings to indoor unit must be installed indoors where the temperature wouldn't drop below 15°C in order to prevent pipings from icing.
- Maximum piping length between indoor unit and tank is 10m.
- Tank unit should be placed on firm, preferably a concrete floor or foundation.

- Tank unit can be aligned using the adjustable feet.
- Protection against overpressure shall be made in accordance with the relevant regulations.
- Connect the heating system according to the installation diagram (see figure).

Installation diagram of the PT storage tank with one coil.

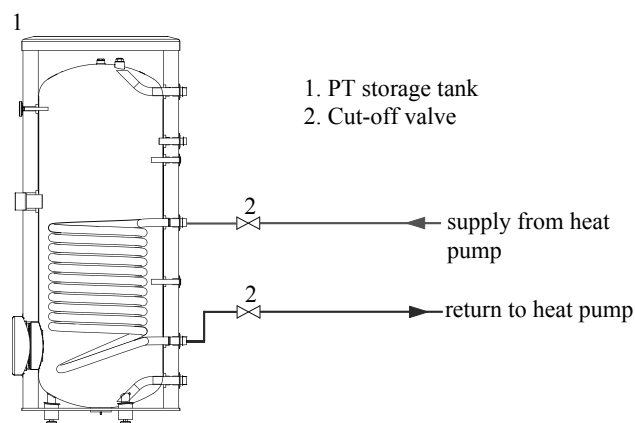

### Connecting hot water tank to water main

- Install a mixing valve if the temperature exceeds 60 °C.
- It is recommended to install a thermostatic mixing valve for stable temperature hot water supply.
- Connect the storage tank to the water supply system of water pressure at least 1bar and max 10bar. Install a pressure reducer if the pressure at the cold water inlet to the tank is higher than allowed.
- Install a safety valve which have a maximum 10.0bar opening pressure on the incoming domestic water line according to outline diagram in order to protect the storage tank against overpressure. Pressure increases during heating the water.
- During heating the water, small and temporary water flow from the safety valve can occur, which indicates that the pressure has increased above the rated value, which triggered the valve. This may in no way be prevented.
- Safety valve drain line should be installed with a decline, in an environment free of freezing and remain open to the atmosphere. The manufacturer is not responsible for flooding the room through the safety valve.
- Blocked safety valve can cause equipment failure. Drain the outflow from the safety valve to the sewerage or drain grate.
- Connect the water supply system according to the installation diagram.

Installation diagram of the PT storage tank with one coil.

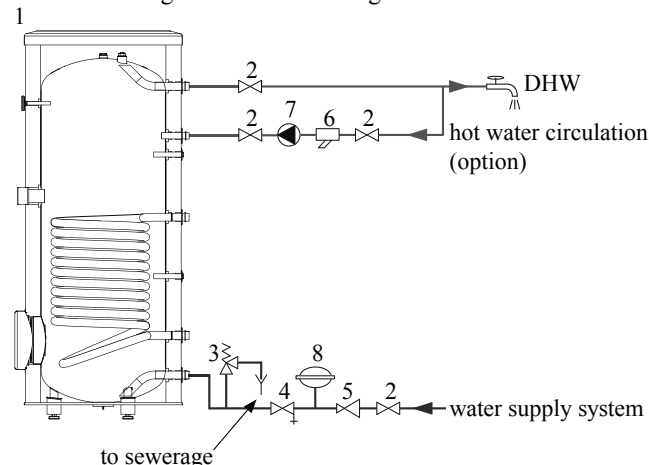

1. PT storage tank
2. Cut-off valve
3. Safety valve
4. Drain valve
5. Pressure reducer (option, if the pressure in the system exceeds the allowable value)
6. Strainer
7. Hot water circulating pump
8. Hot water expansion vessel

### Information

*In order to minimize the flow of water from the safety valve associated with the thermal expansion of the liquid, it is advisable to install a suitable expansion vessel at the cold water connection (see item 8.)*

### CAUTION

*Installation of the appropriate safety valve in the cold water supply line protecting the unit against overpressure is mandatory!*

### CAUTION

*Installation of necking of any kind (such as reducers, dirt pockets, etc.) and cut-off valves between the storage tank and the safety valve is not allowed. Only a T-pipe with a drain valve and a T-pipe with an expansion vessel may be installed in these line sections.*

### CAUTION

*Never block the safety valve or drain line. This can cause a dangerous overpressure in the storage tank.*

### CAUTION

*When heating water, slight, temporary discharge from the safety valve can occur. This is a correct safety valve function. Any attempt to interfere in its operation can lead to the danger and destruction of the storage tank.*

### CAUTION

*Never use the equipment with clogged safety valves.*

### Connection

After the installation and levelling the tank, follow the procedure below (for the connector pipe symbols, refer to page 49):

1. Remove protecting plugs from the connector pipes
2. Connect the hot water intake line (N).
3. Connect the cold water supply line together with the required safety valves (G).
4. If the system has the hot water circulation system, connect it to the connector pipe (L). Otherwise, plug the pipe.
5. Connect the supply (J) and return (H) of the heating medium to the coil.

### CAUTION

*If there is an electric heating module installed in the storage tank, fill the tank with water before connecting it to the electrical installation.*

### Hot water circulation circuit

Hot water circulation function is available for PT300.

#### PT300

If the system has the hot water circulation system, connect it to the port L. (see page 49.)

Then install the Cut-off valves, circulation pump and strainer.

### Connection of external heat source

External heat source, e.g. a gas or oil boiler or electric heater, can be connected on supply line of heating system (XL1).

## Refrigerant circuit

### Connecting refrigerant pipes

See Installation manual for outdoor unit.

### Piping insulation

Install insulation on all piping in order to avoid condensation during cooling operation.

It is also strongly recommended to insulate piping for heating only application in order to avoid getting burned or reducing the heating capacity.

The thickness of the insulation should be 20mm where the relative humidity exceeds 70%.

## Electrical installation

### General

Indoor unit must be installed via an isolator switch in accordance with the local codes and regulations.

- Disconnect the indoor unit, outdoor unit and control unit before insulation testing of the house wiring.
- If the building is equipped with an earth-fault breaker, Hydrolution should be equipped with a separate one.
- For the electrical wiring diagram, see page 22.
- Do not lay communication, sensor or signal cables for external connection close to high voltage lines.
- Minimum cross section of communication, sensor or signal cables for external connection must be 0.5mm<sup>2</sup> up to 50m, for example EKKX, LiYY or equivalent.
- Use screened three core cable for communication between controller (RC-HY20/40-W) and indoor unit (HSB60-W).
- When laying cables into indoor units and controllers, be sure to route the cable grommet (UB1 AND UB2).
- Be careful to route cables not to be damaged by metal edge or trapped by panels.
- Outdoor unit is equipped with a single phase compressor. This means that phase L3 is loaded with up to 15A during compressor operation.

#### NOTE

*Electrical installation and service must be carried out under the supervision of a qualified electrician.*

*Turn off the circuit breaker before carrying out any servicing.*

*Electrical installation and wiring must be carried out in accordance with the stipulations in force.*

*Make sure to turn off the power source during installation.*

#### NOTE

*Do not turn on the power on control until the boiler is filled with water.*

***The circulation pump and immersion heater may become damaged.***

#### NOTE

*If the power source cable is damaged, only authorised person may replace it to avoid danger or damage.*

### Principle diagram, electrical installation

#### HSB60-W

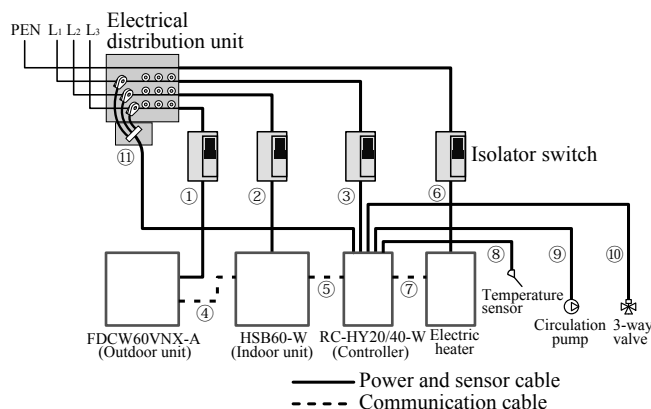

Item		Cable size
①	Power - Outdoor unit	3 cores, 2.0mm <sup>2</sup> (power cable)
②	Power - Indoor unit	3 cores, 1.5mm <sup>2</sup> (power cable)
③	Power - Controller	3 cores, 1.5mm <sup>2</sup> (power cable)
④	Outdoor unit - Indoor unit	2 cores, 1.5mm <sup>2</sup> (communication cable)
⑤	Indoor unit - Controller	3 cores, 0.5mm <sup>2</sup> , LiYY, EKKX or equivalent (communication cable)
⑥	Power - Electrical heater	5 cores, $\phi$ 2.0mm (power cable)
⑦	Controller - Electrical heater	4 cores, 0.5mm <sup>2</sup> (communication cable)
⑧	Controller - Temp sensors	2 cores, 0.5mm <sup>2</sup> (each sensor)
⑨	Controller - Circulation pump	3 cores, 0.75mm <sup>2</sup> (power cable) 2 cores, 0.5mm <sup>2</sup> (communication cable)
⑩	Controller - 3way valve for switching heating/hot water	3 cores, 0.75mm <sup>2</sup>
⑪	Current sensor (RC-HY40-W only)	6 cores, 0.5mm <sup>2</sup>

The cable size shown on the above table is minimum size. Choose appropriate size according to local laws and regulations.

#### NOTE

*When laying cables into the indoor unit and controllers, be sure that the cables are groomed to avoid excessive resistance to the terminal blocks.*

*If there is an excessive resistance applied to the wiring, they may disconnect and damage the unit (short-circuit)*



## Electrical components

### HSB60-W

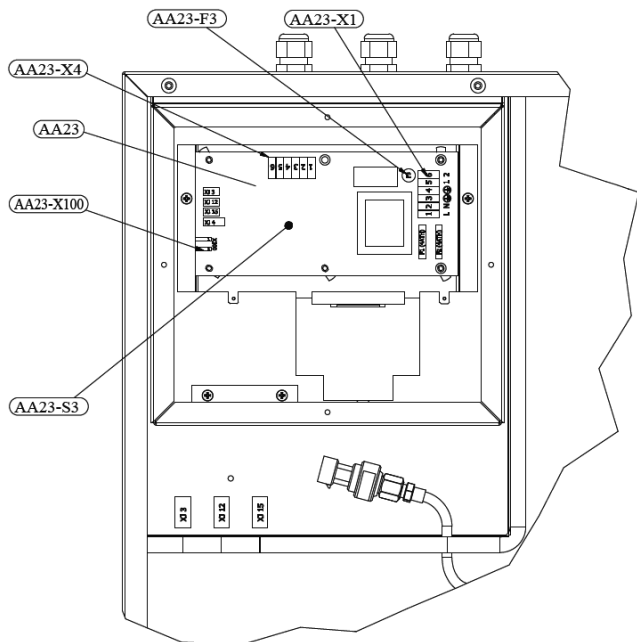

#### Explanation

- AA23            Communication board
- AA23-F3       Fuse for external heating cable
- AA23-S3       DIP switch, addressing of outdoor unit
- AA23-X1       Terminal block, incoming supply, connection of KVR
- AA23-X4       Terminal block, communication with indoor module / control module
- AA23-X100     Terminal block, communication outdoor module FDCW

### RC-HY20-W

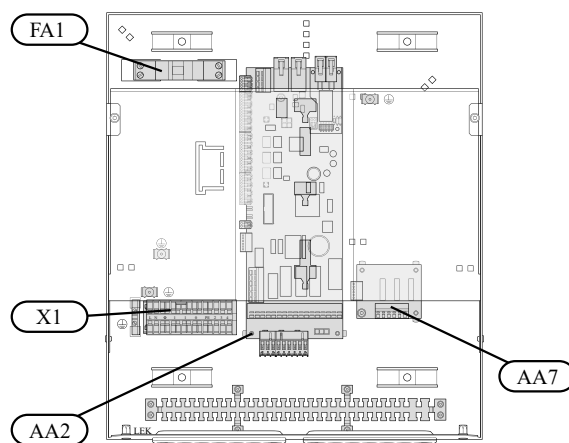
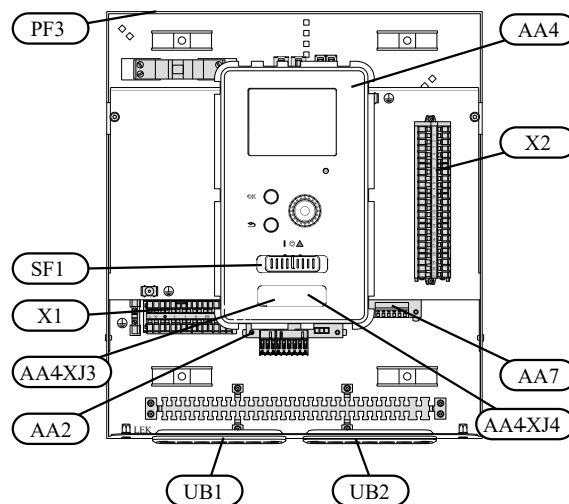

#### Explanation

- AA2            Base card
- AA4            Display unit
- AA4-XJ3       USB socket
- AA4-XJ4       Service outlet (No function)
- AA7            Extra relay circuit board
- FA1            Miniature circuit-breaker
- X1            Terminal block, incoming electrical supply
- X2            Terminal block, control signal circulation pump, sensors AUX inputs and heat pump
- SF1            Switch
- PF3            Serial number plate
- UB1            Cable grommet, incoming supply electricity, power for accessories
- UB2            Cable grommet, signal

**RC-HY40-W**

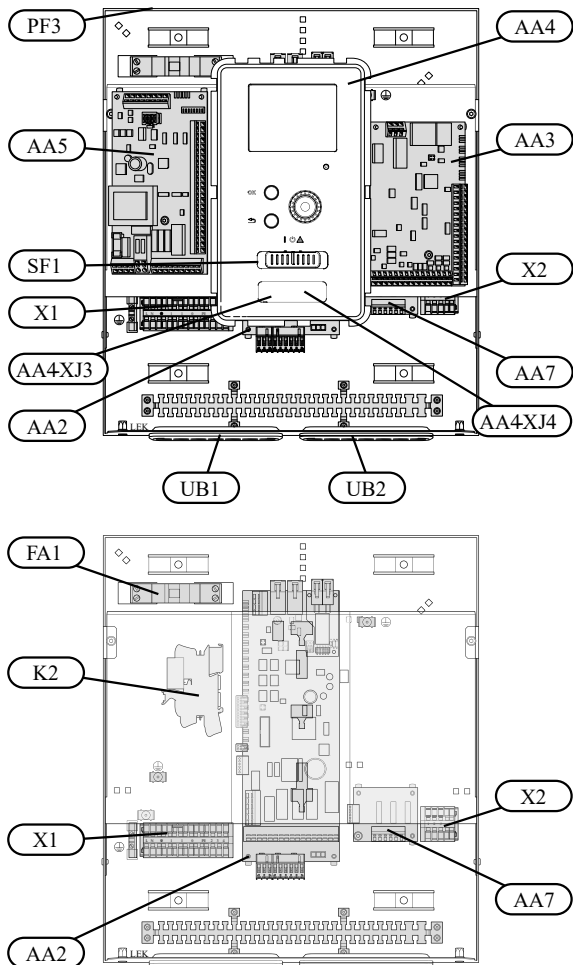

**Accessibility, electrical connection for controller**

The cover of the control module is opened using a Torx 25 screwdriver. Assembly takes place in the reverse order.

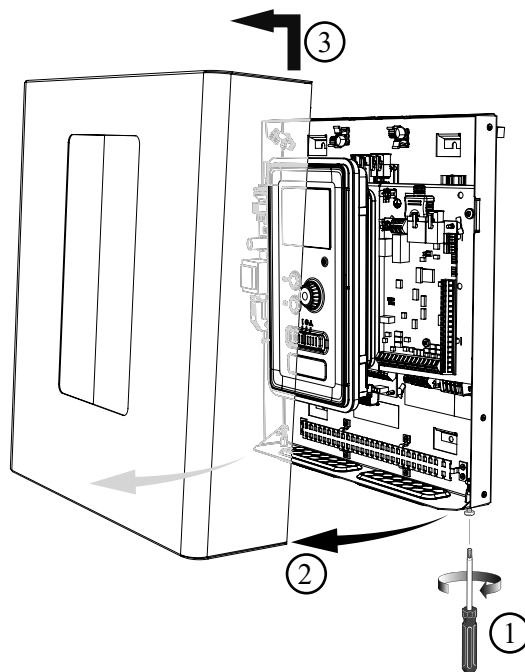

**NOTE**

The cover to access the base board is opened using a Torx 25 screwdriver

**Explanation**

- AA2 Base card
- AA3 Input circuit board
- AA4 Display unit
- AA4-XJ3 USB socket
- AA4-XJ4 Service outlet (No function)
- AA5 Accessory card
- AA7 Extra relay circuit board
- FA1 Miniature circuit-breaker
- K2 Emergency mode relay
- X1 Terminal block, incoming electrical supply
- X2 Terminal block, AUX4 - AUX6
- SF1 Switch
- PF3 Serial number plate
- UB1 Cable grommet, incoming supply electricity, power for accessories
- UB2 Cable grommet, signal

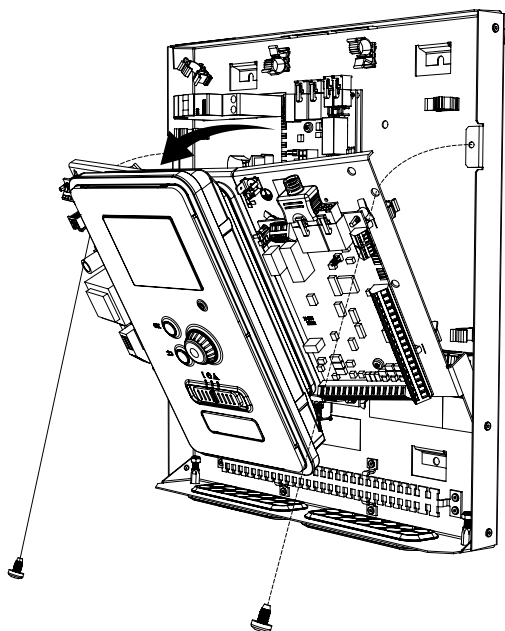

The display may need to be moved for easier access when connecting electrics. This is easily done by following these steps.

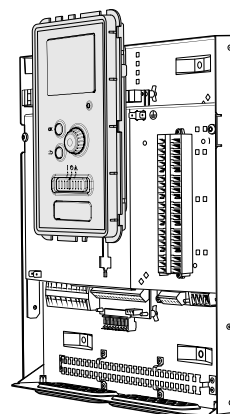
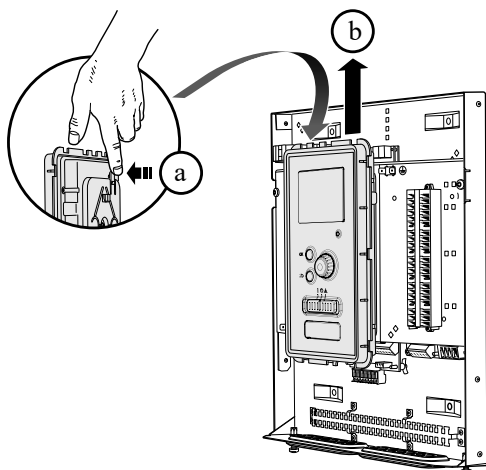

1. Press in the catch on the upper rear side of the display unit towards you (a) and move the display unit upwards (b) so that the mountings unhook from the panel.

4. Secure the display on the panel.

5. When the electrical connection is ready the display must be reinstalled with three mounting points again, otherwise the front cover cannot be installed.

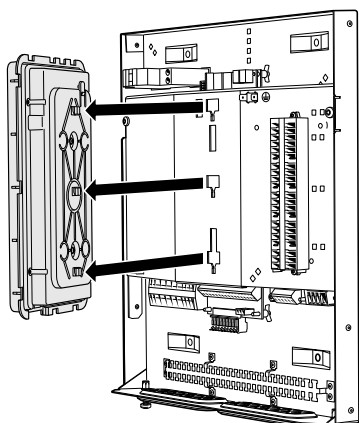

2. Lift the display unit from its mountings.

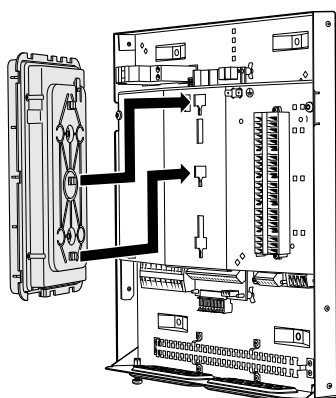

3. Align the two lower mountings on the reverse of the display unit with the two upper holes in the panel as illustrated.

### Cable lock

Use a suitable tool to release/lock cables in the terminal block.

#### HSB60-W, RC-HY20/40-W

Terminal block on the electrical card

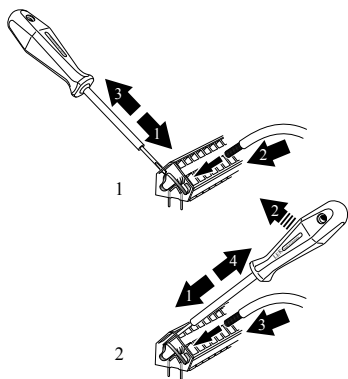

Terminal block

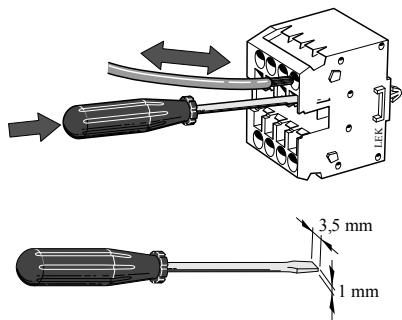

### Connection for HSB60-W

#### NOTE

To prevent interference, unscreened communication and/or sensor cables to external connections must not be laid closer than 20cm from high voltage cables.

### Power source

#### Indoor unit

In case of HSB60-W, power source is made to indoor unit, outdoor unit and controller separately. 230V 1AC 50Hz is applied.

For indoor unit, incoming supply is connected on AA23-X1 terminal.

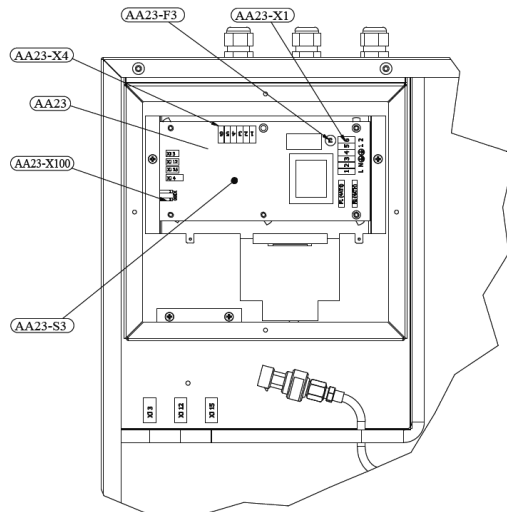

For outdoor unit, incoming supply is connected on TB terminal. See figure on connection between indoor and outdoor unit.

### Controller

#### Connection between indoor and outdoor unit

The communication cable between indoor and outdoor unit is connected between terminal AA23-X100 in indoor unit and TB in outdoor unit. Screened 2 cores cable is recommended.

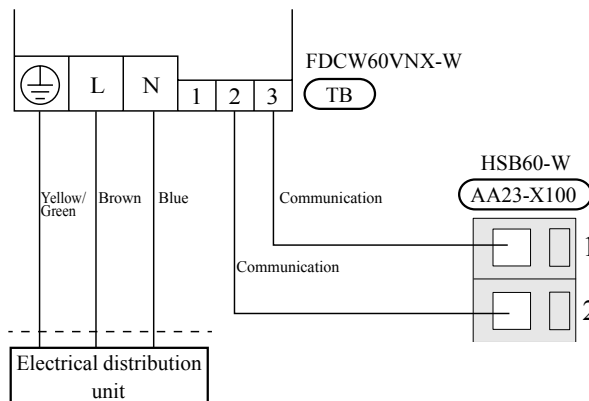

**Connection between indoor unit and controller**

See connection for RC-HY20/40-W

**Cascade connection setting**

In case of cascade connection system, it is necessary to allot unique address to each indoor unit. Set the DIP switch S3-1, -2 and -3 according to the following table.

Address	S3:1	S3:2	S3:3
1	OFF	OFF	OFF
2	On	OFF	OFF
3	OFF	On	OFF
4	On	On	OFF
5	OFF	OFF	On
6	On	OFF	On
7	OFF	On	On
8	On	On	On

**Recommended fuse size for HSB series**

The recommended fuse size shown in the following table is reference value. Choose appropriate size according to local laws and regulations.

	Fuse size
Indoor unit (HSB60-W)	6A / 230V 1AC 50Hz
Outdoor unit (FDCW60VNX-W)	20A / 230V 1AC 50Hz
Controller (RC-HY20/40-W)	10A / 230V 1AC 50Hz
Electric heater (ELK9M) (reference)	16A/400V 3NAC 50Hz

**Recommended cable size for HSB60-W**

The recommended cable size shown in the following table is reference value. Choose appropriate size according to local laws and regulations.

	Cable size
Power – Indoor unit	3 cores, 1.5mm <sup>2</sup> (power cable)
Power – Outdoor unit	3 cores, 2.0mm <sup>2</sup> (power cable)
Indoor unit – Outdoor unit	2 cores, 1.5mm <sup>2</sup> (communication cable)
Indoor unit – Controller	3 cores, 0.5mm <sup>2</sup> , LiYY, EKKX or equivalent (communication cable)

**RC-HY20/40-W**

Cable connection is different according to the system structure. Refer to the connection method according to the indoor unit

**Power source**

Connect the power cable on X1 terminal as shown below.

RC-HY20/40-W must be installed via an isolator switch with a minimum breaking capacity of 3mm. Minimum cable area must be sized according to the fuse rating used.

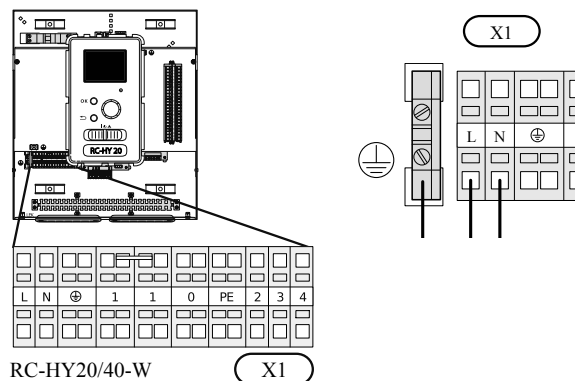

**RC-HY20-W**

**Connection between controller and indoor unit**

**HSB60-W**

Signal cable is connected between the controller and the indoor unit with screened 3 cores cable for HSB series.

Connect the port 19 (A), 20 (B) and 21 (GND) on X2 terminal on RC-HY20-W on the port 1,2 and 3 on X4 terminal on AA23 board respectively

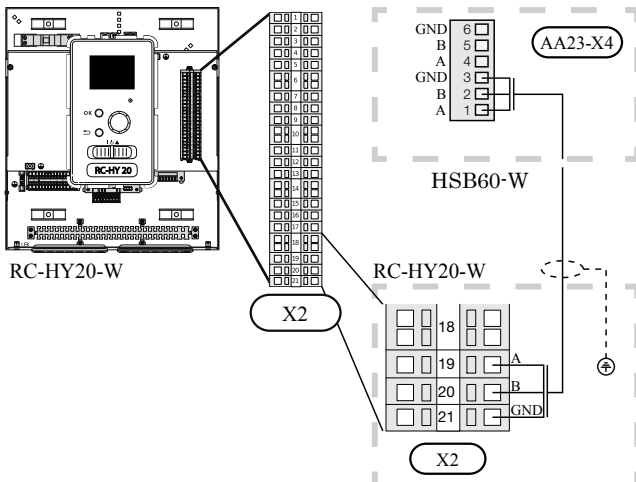

**Connection between controller and circulation pump (GP12)**

For HSB60-W, circulation pump (GP12) is installed outside of indoor unit. Choose correct terminal according to the type of controller.

Connect the port 5, 6 and 7 on X4 terminal on AA2 board on RC-HY20-W to the port PE, N and L on circulation pump respectively. Control signal cable is connected between the port 1 and 2 on X2 terminal on RC-HY20-W and PWM and GND on circulation pump respectively as shown below.

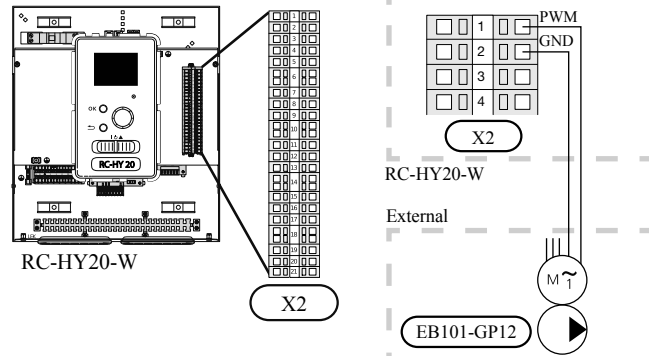
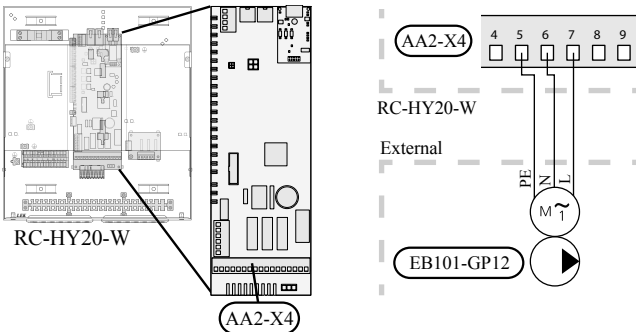

**Connection between controller and 3-way valve (QN10/QN12)**

3-way valve is used for switching heating / hot water production (QN10), or switching heating / cooling (QN12). Install appropriate valves according to the system structure on site.

HSB60-W is not equipped with 3-way valve. Install the valves on right position according to the diagram and connect wires on appropriate port according to the type of controller.

• **3-way valve for Heating / Hot water (QN10)**

Connect the N, Control and L wire on 3-way valve to the port 2, 3 and 4 on X4 terminal on AA2 board on RC-HY20-W respectively as shown below.

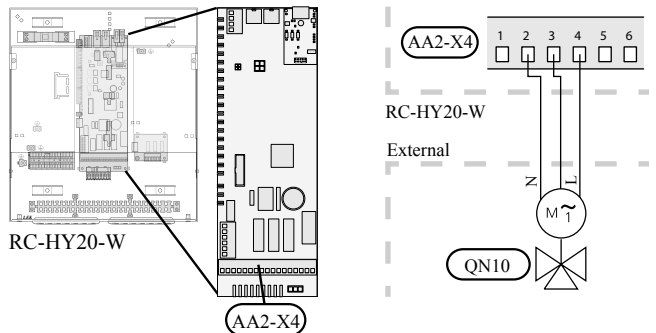

• **3-way valve for Heating / Cooling (QN12)**

QN12 can be controlled with potential free variable relay. Connect L and control wire on 3-way valve to the port 15 and 16 on X4 terminal on AA2 board on RC-HY20-W respectively. Also, connect L and N wire to power source as shown below.

Additional setting is necessary in menu 5.4. See Menu system for details.

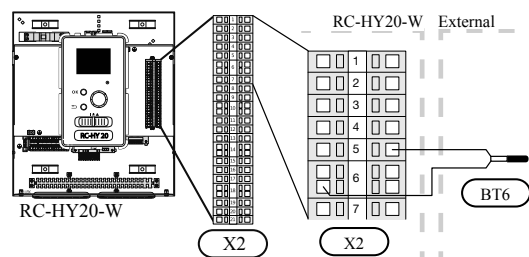
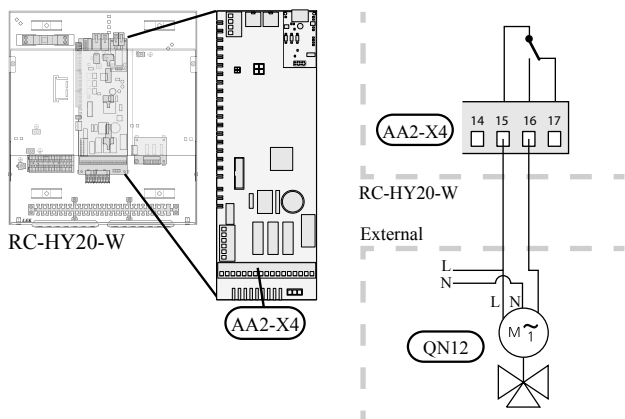

• **Hot water sensor BT7 (tank top)**

A temperature sensor for hot water top (BT7) can be connected to RC-HY20 to show the water temperature at the top of the tank (if it is possible to install a sensor at the top of the tank).

Connect the sensor to the port 4 and 6 on X2 terminal.

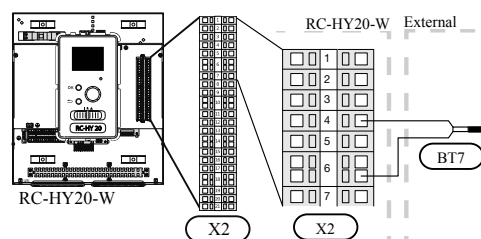

• **Temperature sensor BT63, outlet at additional heater**

This sensor is used in case electric heater is placed before 3-way valve (QN10) for switching heating/hot water (see page 180 for diagram).

Connect temperature sensor, external supply after electric heater (BT63) to the port 9 and 10 on terminal X2.

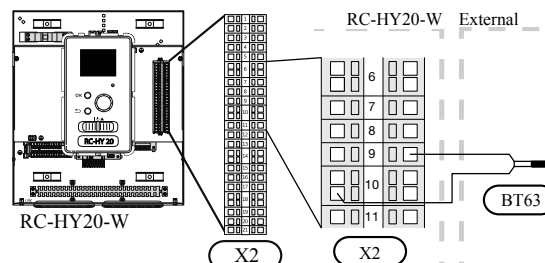

• **Temperature sensor BT25, outlet for heating**

This sensor is used in case electric heater is placed after 3-way valve (QN10) for switching heating/ hot water.

Connect temperature sensor, external supply (BT25) to the port 8 and 10 on X2 terminal.

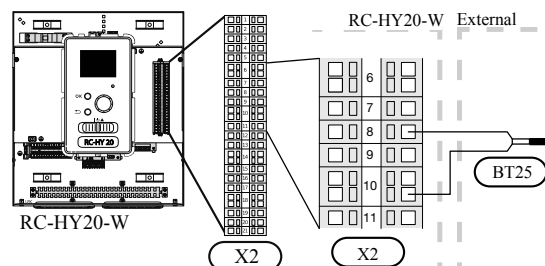

**CAUTION**

The relay outputs can have a max load of 2 A at resistive load (230V AC).

**Connection between controller and sensors**

Sensor connection is different according to the combination of indoor unit and controller. Refer to the appropriate combination mentioned below.

Use 2 cores cable with a minimum 0.5mm<sup>2</sup> cross section.

Regarding other sensors not mentioned in this chapter, refer to page 64, Option connections.

• **Ambient air temperature sensor BT1**

Install ambient air temperature sensor (BT1) in the shade on a wall facing north or north-west, so it is unaffected by the morning sun.

Connect the sensor to the port 3 and 6 on X2 terminal.

If a conduit is used it must be sealed to prevent condensation in the sensor capsule.

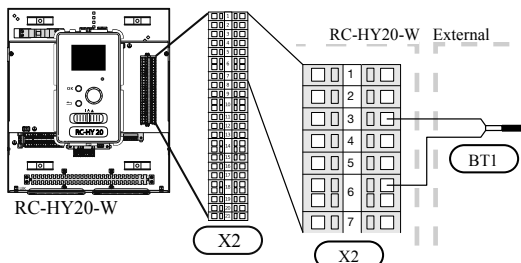

• **Hot water charging sensor BT6 (tank bottom)**

The temperature sensor, hot water charging (BT6) is placed in the submerged tube on the water heater.

Connect the sensor to the port 5 and 6 on X2 terminal.

Hot water charging is activated in menu 5.2 or in the start guide.

• **Temperature sensor BT71, return line for heating**

This sensor is used in case electric heater is placed after 3-way valve (QN10) for switching heating/ hot water.

For connection, see page 64, AUX inputs.

• **Temperature sensor BT64, outlet for cooling**

This sensor is used in case cooling application is required.

For connection, see page 64, AUX inputs.

**Option connections**

◦ **Room sensor BT50**

Room sensor can be connected to controller.

The room temperature sensor has up to three functions:

1. Show current room temperature in the control module display.
2. Option of changing the room temperature in °C.
3. Makes it possible to change/stabilise the room temperature.

Install the sensor in a neutral position where the set temperature is required. A suitable location is on a free inner wall in a hall approx. 1.5 m above the floor.

Do not install the sensor where correct room temperature cannot be detected such as in a recess, between shelves, behind a curtain, above or close to a heat source, in a draft from an external door or in direct sunlight.

Closed radiator thermostats can also cause problems.

The control module can operate without the sensor, but if user wants to read off the accommodation's indoor temperature in controller display, the sensor must be installed.

Connect the room sensor to the port 7 and 10 on X2 terminal.

If the sensor is to be used to change the room temperature in °C and/or to change/stabilise the room temperature, the sensor must be activated in menu 1.9.4.

If the room sensor is used in a room with underfloor heating, it should only have an indicative function, not control of the room temperature.

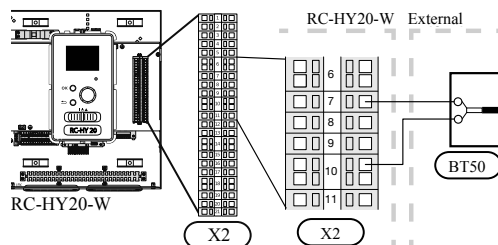

**CAUTION**

*Changes of temperature in accommodation take time. For example, short time periods in combination with underfloor heating will not give a noticeable difference in room temperature.*

Use 2 cores cable with a minimum 0.5mm<sup>2</sup> cross section.



◦ Step controlled additional heat

**NOTE**

Mark up any junction boxes with warnings for external voltage.

External step controlled additional heat can be controlled by up to three potential-free relays in the control module (3 step linear or 7 step binary). Alternatively two relays (2 step linear or 3 step binary) can be used for step controlled additional heat, which means that the third relay can be used to control the immersion heater in the water heater/accumulator tank.

Step in occurs with at least 1 minute intervals and step outs with at least 3 seconds intervals.

Step 1 is connected to terminal block X2:2 on the additional relay board (AA7).

Step 2 is connected to terminal block X2:4 on the additional relay board (AA7).

Step 3 or immersion heater in the water heater/accumulator tank is connected to terminal block X2:6 on the additional relay board (AA7).

The settings for step controlled additional heat are made in menu 4.9.3 and menu 5.1.12.

All additional heat can be blocked by connecting a potential-free switch function to the software controlled input on terminal block X2 which is selected in menu 5.4.

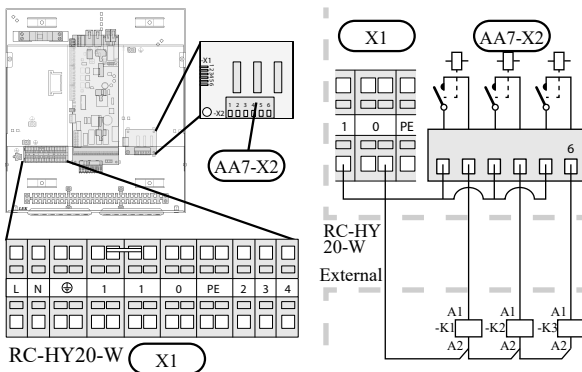

If the relays are to be used for control voltage, bridge the supply from terminal block X1:1 to X2:1, X2:3 and X2:5 on additional relay board (AA7). Connect the neutral from the external additional heat to terminal block X1:0.

Use a cable with appropriate cross section.

For connection, see the installation manual for additional heater.

◦ Relay output for emergency mode

**NOTE**

Mark up any junction boxes with warnings for external voltage.

When the switch (SF1) is in "Δ" mode (emergency mode) the circulation pump is activated (EB101-GP12).

**CAUTION**

No hot water is produced when emergency mode is activated.

The emergency mode relay can be used to activate external additional heat. Between the port 2 and 4 is closed during emergency mode. An external thermostat must be connected to the control circuit (port 4) to control the temperature. Ensure that the heating medium circulates through the external additional heating.

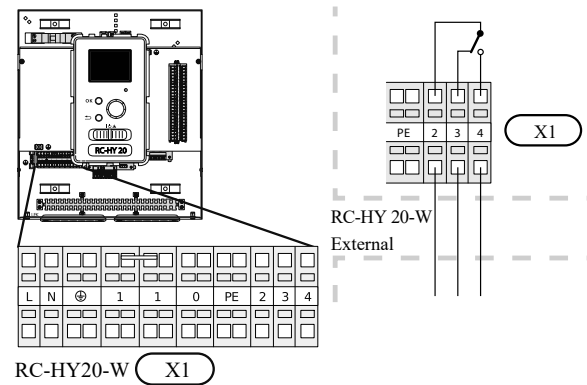

If the relay is to be used for control voltage, bridge the supply from terminal block X1:1 to X1:2 and connect neutral and control voltage from the external additional heat to X1:0 (N) and X1:4 (L).

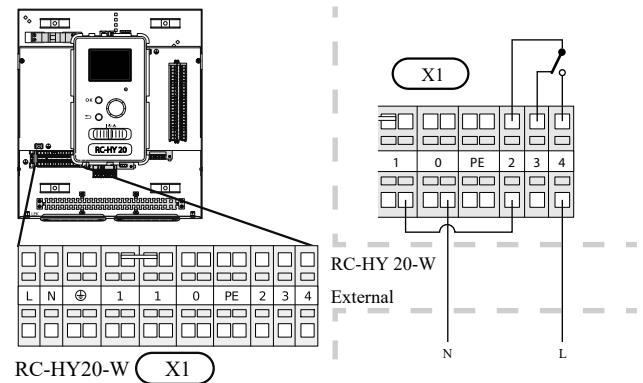

◦ External circulation pump

Connect the external circulation pump (GP10) to terminal block X4:9 (PE), X4:10 (N) and X4:11 (230V) on the base board (AA2) as illustrated.

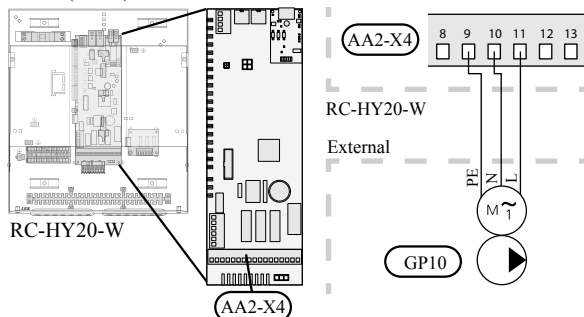

◦ AUX inputs

Other external inputs are available on the port 11 through 18 on X2 terminal on RC-HY20-W.

AUX1, 2, 3, 4, 5, and 6 correspond to the port 11, 12, 13, 15, 16 and 17 respectively. Port 14 and 18 are GND and are common to the all auxiliary circuit. Connect a sensor or switch between AUX and GND with a two-core cable with a minimum cross section of 0.5mm<sup>2</sup>.

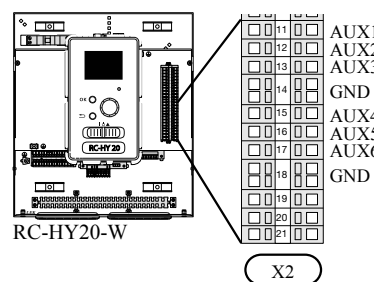

Select the appropriate function in menu 5.4.

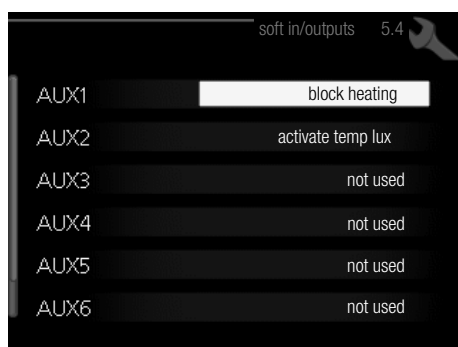

■ Temperature sensor, cooling/heating (BT74)

Additional room sensor (BT74) is applied in case user wants to determine the operation mode (cooling/heating) with a temperature in a particular room.

This option can be chosen only in case cooling function is available.

■ Temperature sensor, external return line (BT71)

Temperature sensor BT71 is applied in case additional heater is placed after 3-way valve.

■ Temperature sensor, flow line cooling (BT64)

Temperature sensor BT64 is required in case 4-pipe system is used for cooling operation.

This option can be chosen only in case cooling function is activated.

■ Contact for external tariff blocking

In cases where external tariff blocking is required it must be connected to terminal block X2.

Tariff blocking means that the additional heat, the compressor, heating and cooling are disconnected by connecting a potential free switch function to the input selected in menu 5.4.

A closed contact results in the electrical output being disconnected.

■ Switch for "SG ready"

**NOTE**

*This function can only be used in mains networks that support the "SG Ready"-standard. "SG Ready" requires two AUX inputs.*

This function can only be used in power source networks that support the "SG Ready" standard. "SG Ready" requires two AUX inputs.

"SG Ready" is a smart tariff management scheme in which electricity supplier can affect indoor and hot water temperature or simply prohibits additional heat and/or the compressor operation in heat pump at certain period of the day. You can choose which operation mode is affected by this function in menu 4.1.5 after the function is activated.

Choose two external input circuits and connect potential-free switches, and set "SG Ready A" and "SG Ready B" in menu 5.4. The system works differently according to the combination of the circuit open/closed.

◦ Blocking (A: Closed, B: Open)

"SG Ready" is active. Compressor operation and additional heat is prohibited.

◦ Normal mode (A: Open, B: Open)

"SG Ready" is not active. No effect on the system.

◦ Low price mode (A: Open, B: Closed)

"SG Ready" is active. The system operates to provide higher capacity than normal mode by using lower tariff electricity. You can select the operation mode (heating/hot water/cooling) affected by this function in menu 4.1.5.

◦ Overcapacity mode (A: Closed, B: Closed)

"SG Ready" is active. The system supplies higher capacity than Low price mode since the electricity price is supposed to be very low in this mode. You can select the operation mode (heating/hot water/cooling) affected by this function in menu 4.1.5.

■ Contact for activation of “temporary lux”

Temporary hot water production function “temporary lux” is activated with this signal. Connect the terminals with a potential-free switch and choose the function in menu 5.4.

“Temporary lux” is activated only when the switch is closed.

■ Contact for activation of “external adjustment”

Target temperature offset for supply temperature or room temperature can be done with this signal.

When a room sensor is connected and activated, the target room temperature is offset in °C if the switch is closed. When a room sensor is not connected, target supply water temperature (heat curve) is offset instead. The degree of offset can be set in menu 5.4.

■ Switch for external alarm

Alarms from external devices can be connected to the control and appear as an info alarm. Potential-free signal of NO or NC type can be connected.

■ Switch for external blocking

This function is used in case certain operation mode needs to be prohibited. The operation at selected operation mode is prohibited when the switch is closed. Following functions can be managed.

- Additional heat
- Compressor operation
- Heating mode
- Cooling mode
- Hot water mode

• AUX outputs

External output is available on the port 15 to 17 on X4 terminal on AA2 board on RC-HY20-W. The relay output can have a max load of 2A at resistive load.

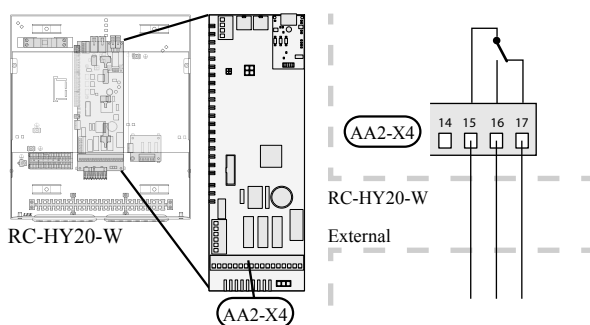

Following functions are available. Select the function in menu 5.4.

◦ Indication of buzzer alarm

When an alarm occurs, the circuit becomes closed between the port 15 and 16. During normal operation, the port 15 and 17 is closed.

◦ Cooling mode indication / Active cooling mode (4-pipe cooling)

When the system turns into cooling mode, the circuit

becomes closed between the port 15 and 16. By using this signal, it is possible to switch 3-way valve for 4-pipe cooling or to assemble a display circuit indicating cooling mode. For details of connecting the 3-way valve, refer to page 61.

◦ External pump control (GP10)

External pump (GP10) is used in case additional heater is placed after 3-way valve that switches heating/hot water.

Connect the circulation pump as shown below using the port 15 and 16 on X4 terminal.

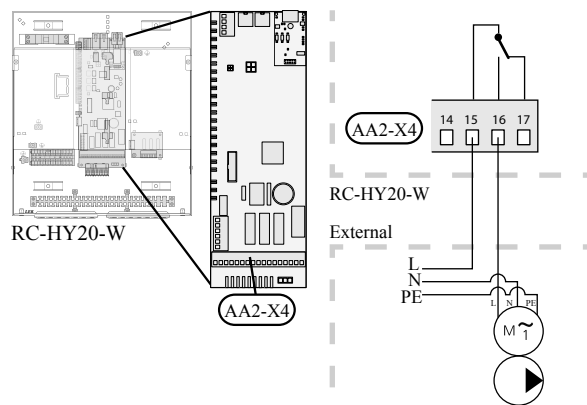

◦ myUpway™

Connect the network connected cable (straight, Cat.5e UTP) with RJ45-contact (male) to contact AA4-X9 on the display unit (as illustrated). Use the cable grommet (UB2) in the control module for cable routing.

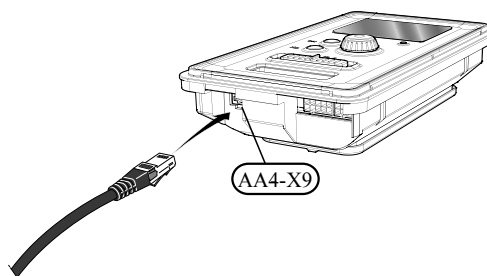

**RC-HY40-W**

**Connection between controller and indoor unit**

**HSB60-W**

Connect the port 1(A), 2(B) and 3(GND) on X4 terminal on AA5 board on RC-HY40-W to the port 1, 2 and 3 on X4 terminal on AA23 board on HSB60-W respectively.

In case several systems are connected to one controller, connect the port 4, 5 and 6 on X4 terminal on AA23 board on HSB60-W close to the controller to the port 1, 2 and 3 on X4 terminal on AA23 board on another HSB.

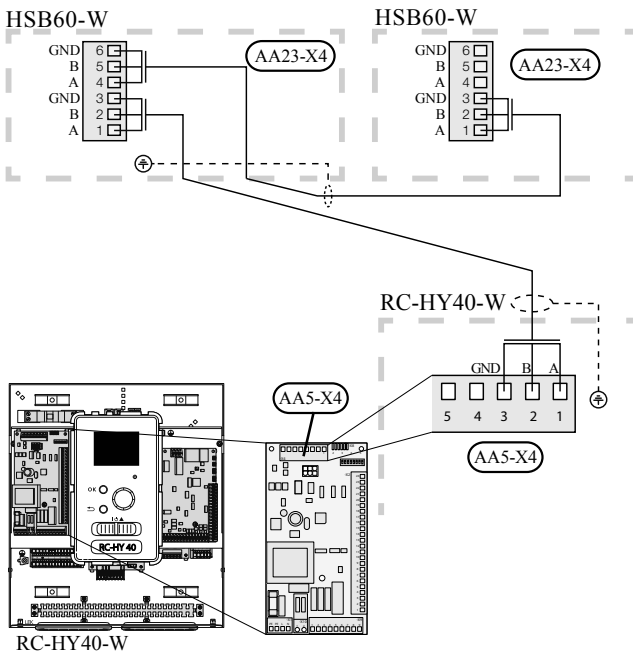

**Connection between controller and circulation pump (GP12)**

For HSB60-W, circulation pump (GP12) is installed outside of indoor unit. Choose correct terminal according to the type of controller.

Connect the port 5, 6 and 7 on X4 terminal on AA2 board on RC-HY40-W to the port PE, N and L on circulation pump (EB101-GP12) respectively. Control signal cable is connected between the port 7 and 8 on X4 terminal on AA3 board on RC-HY40-W and GND and PWM on circulation pump respectively as shown below.

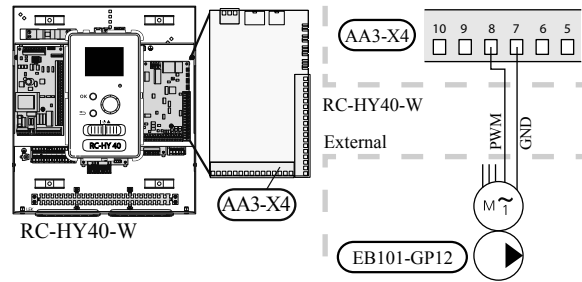
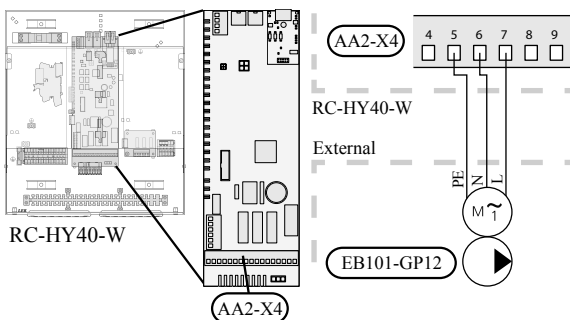

RC-HY40-W can connect and control up to two pumps. Connect the port 12, 13 and 15 on X4 terminal on AA2 board on RC-HY40-W to the port PE, N and L on second circulation pump (EB102-GP12) respectively. Control cable is connected between the port 5 and 6 on X4 terminal on AA3 board on RC-HY40-W and GND and PWM on circulation pump respectively as shown below.

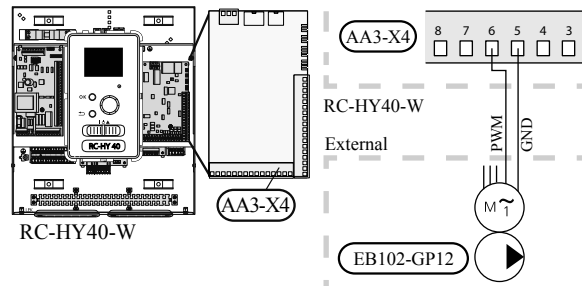
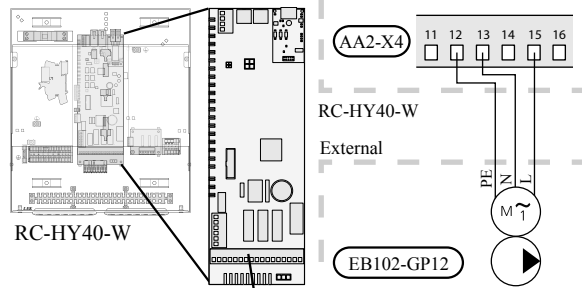

• **3-way valve for Heating / Hot water (QN10)**

Refer to 3-way valve connection for HSB60-W with RC-HY20-W (Page 60)

• **3-way valve for Heating / Cooling (QN12)**

QN12 can be controlled with potential free variable relay. Connect L and Control wire on 3-way valve to the port C and NO on X7 terminal on AA3 board on RC-HY40-W respectively. Also, connect L and N wire to power source as shown below.

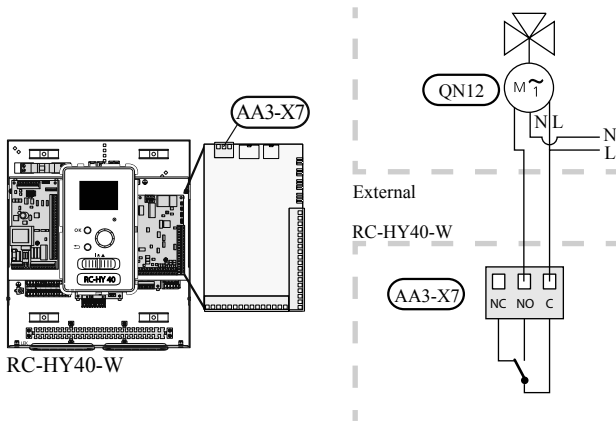

**Connection between controller and sensors**

Sensor connection is different according to the combination of indoor unit and controller. Refer to the appropriate combination mentioned below.

Use 2 cores cable with a minimum 0.5mm<sup>2</sup> cross section.

Regarding other sensors not mentioned in this chapter, refer to page 68, option connections.

• **Ambient air temperature sensor BT1**

Install ambient air temperature sensor (BT1) in the shade on a wall facing north or north-west, so it is unaffected by the morning sun for example.

Connect the sensor to the port 1 and 2 on X6 terminal on AA3 board.

If a conduit is used it must be sealed to prevent condensation in the sensor capsule.

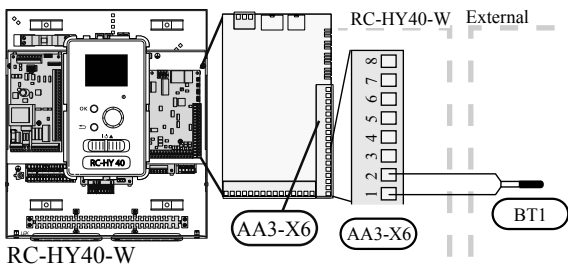

• **Hot water charging sensor BT6 (tank bottom)**

The temperature sensor, hot water charging (BT6) is placed in the submerged tube on the water heater.

Connect the sensor to the port 7 and 8 on X6 terminal on AA3 board.

Hot water charging is activated in menu 5.2 or in the start guide.

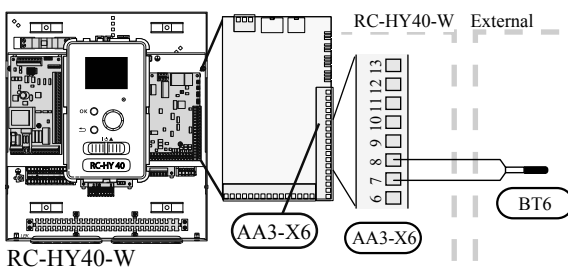

• **Hot water sensor BT7 (tank top)**

A temperature sensor for hot water top (BT7) can be connected to RC-HY40-W to show the water temperature at the top of the tank (if it is possible to install a sensor at the top of the tank).

Connect the sensor to the port 15 and 16 on X6 terminal on AA3 board.

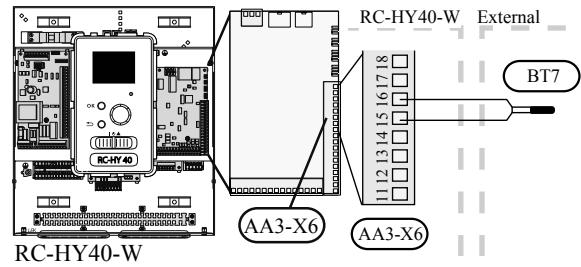

• **Temperature sensor BT63, outlet at additional heater**

This sensor is used in case electric heater is placed before 3-way valve (QN10) for switching heating/ hotwater (see page 180 for diagram).

For connection, see page 69, AUX inputs.

• **Temperature sensor BT25, outlet for heating**

This sensor is used in case electric heater is placed after 3-way valve (QN10) for switching heating/ hot water.

Connect temperature sensor, external supply line (BT25) to the port 5 and 6 on X6 terminal on AA3 board.

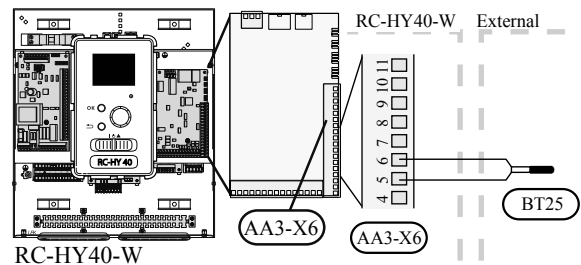

• **Temperature sensor BT71, return line for heating**

This sensor is used in case electric heater is placed after 3-way valve (QN10) for switching heating/ hot water.

Connect temperature sensor, external return line (BT71) to the port 17 and 18 on X6 terminal on AA3 board.

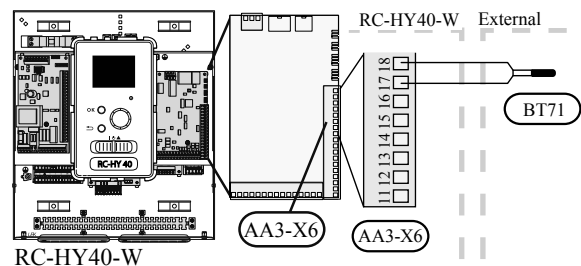

• **Temperature sensor BT64, outlet for cooling**

This sensor is used in case cooling application is required.  
For connection, see page 69, AUX inputs.

**Optional connections**

◦ **Load monitor**

In case many power electrical appliances are connected in the property and the electric heater is energised at the same time, there is a risk of tripping the main fuse of the property.

The control module has an integrated load monitor that controls the power steps of the electric heater by disconnecting step by step in the event of overload in a phase. It will be reconnected if other current consumption is reduced.

**Connecting current sensors**

A current sensor (BE1 - BE3) should be installed on each incoming phase conductor in to the electrical distribution unit to measure the current. This is best done in the electrical distribution unit.

Connect the current sensors to a multi-core cable in an enclosure next to the electrical distribution unit. Use a multi-core cable of at least 0.5 mm<sup>2</sup> from the enclosure to the heat pump.

Connect the cable to terminal block X4:1 to 4.

X4:1 is the common terminal block for the three current sensors.

Set the size of the property's main fuse in menu 5.1.12.

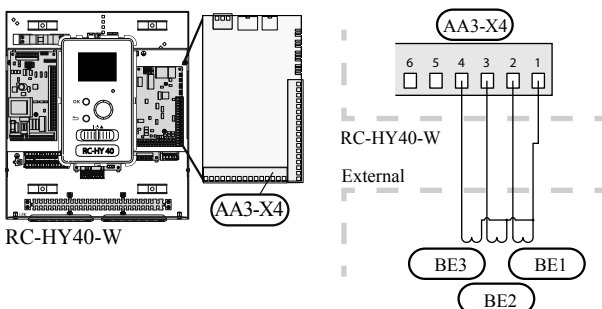
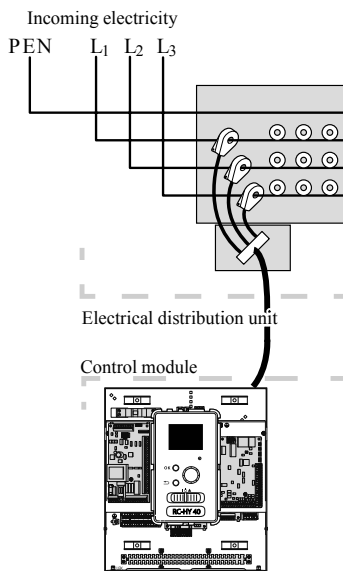

◦ **Room sensor BT50**

Refer to Room sensor BT50 for RC-HY20-W for function and installation place.

Connect the room sensor to terminal block X6:3 and X6:4 on the input board (AA3).

If the sensor is to be used to change the room temperature in °C and/or to change/stabilise the room temperature, the sensor must be activated in menu 1.9.4.

If the room sensor is used in a room with underfloor heating, it should only have an indicatory function, not control of the room temperature.

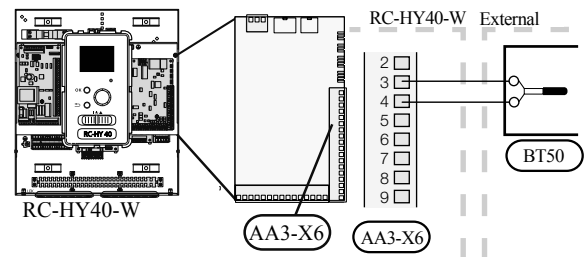

**CAUTION**

*Changes of temperature in accommodation take time. For example, short time periods in combination with underfloor heating will not give a noticeable difference in room temperature.*

• **Step controlled additional heat**

Refer to the explanation for RC-HY20-W (Page 63).

• **Relay output for emergency mode**

Refer to the explanation for RC-HY20-W (Page 63).

• **External circulation pump**

Refer to the explanation for RC-HY20-W (Page 64).

### ◦ AUX inputs

Up to 6 other external inputs are available on RC-HY40-W.

AUX1 through 3 correspond to the port 9/10, 11/12, 13/14 respectively on X6 terminal on AA3 board. AUX4 through 6 correspond to the port 1, 2 and 3 on X2 terminal on RC-HY40-W. Port 4 on X2 terminal is GND and is common to AUX4 through 6. Connect a sensor or switch between AUX and GND with a 2 cores cable with a minimum cross section of 0.5mm<sup>2</sup>.

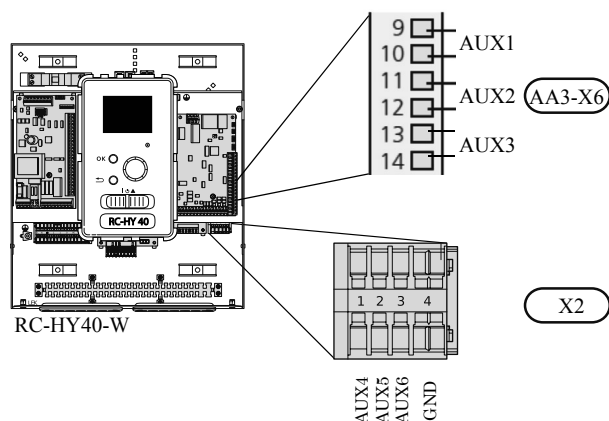

Select the appropriate function in menu 5.4.

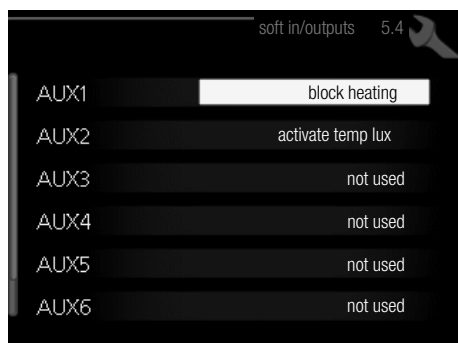

The following functions are available. For details, see AUX inputs for RC-HY20-W (Page 64)

- Temperature sensor, external supply at additional heat before reversing valve (BT63)
- Temperature sensor, cooling/heating (BT74)
- Temperature sensor, flow line cooling (BT64)
- Temperature sensor, boiler (BT52)
- Contact for external tariff blocking
- Switch for “SG ready”
- Contact for activation of “temporary lux”
- Contact for activation of “external adjustment”
- Switch for external alarm
- Switch for external blocking

### ◦ AUX outputs

External output is available on the port NC, NO and C on X7 terminal on AA3 board on RC-HY40-W. The relay output can have a max load of 2A at resistive load.

Following functions are available. Select the function in menu 5.4.

#### ◦ Indication of buzzer alarm

When an alarm occurs, the circuit becomes closed between the port NO and C. During normal operation, the port NC and C is closed.

#### ◦ Cooling mode indication / Active cooling mode (4-pipe cooling)

When the system turns into cooling mode, the circuit becomes closed between the port NO and C. By using this signal, it is possible to switch 3-way valve for 4-pipe cooling or to assemble a display circuit indicating cooling mode. For details of connecting the 3-way valve, refer to page 67.

#### ◦ External pump control (GP10)

External pump (GP10) is used in case additional heater is placed after 3-way valve that switches heating/hot water.

Connect the circulation pump using the port NO and C on X7 terminal on AA3 board as shown below.

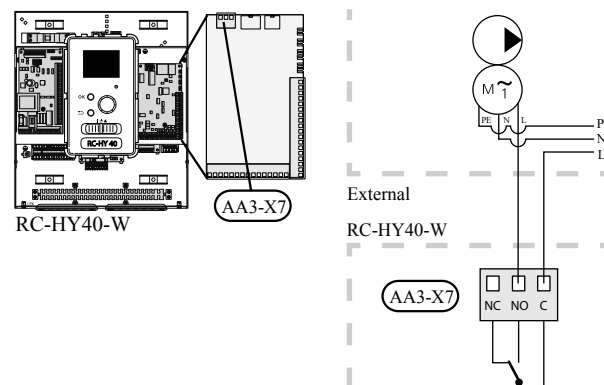

### ◦ myUpway™

Connect the network connected cable (straight, Cat.5e UTP) with RJ45-contact (male) to contact AA4-X9 on the display unit (as illustrated). Use the cable grommet (UB2) in the control module for cable routing.

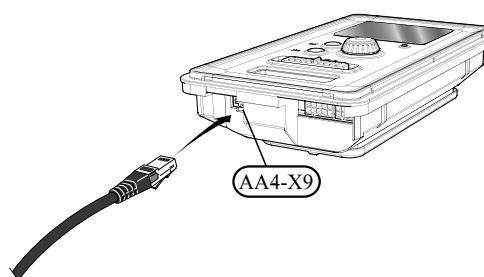

## Commissioning and adjusting Preparations

Before starting commissioning, check the followings;

- The signal cable is connected between indoor unit and outdoor unit as well as indoor unit and controller according to the instruction.
- The power cable is connected to indoor unit, outdoor unit and controller according to the instruction.
- Operation switch in controller is in the position .
- The service valves on outdoor unit (QM35 and QM36) are open.
- Drain valve is closed before filling water in the system.
- Temperature limiter and electrical switch are not tripped.
- The system is filled with water and well vented.
- There are no leaks on the water pipe.

## Filling and venting

### Hot water tank

1. Open the hot water tap as well as venting valve if applicable, and then open the cold water cut-off valve at the inlet.
2. Fill the storage tank until obtaining uniform water outflow at the hot water tap, and then close the hot water tap and venting valve.
3. Fill the water heater coil in the tank. See Climate system for details.

After the installation and levelling the tank, follow the procedure below (for the connector pipe symbols, refer to page 19):

1. Remove protecting plugs from the connector pipes
2. Connect the hot water intake line (N).
3. Connect the cold water supply line together with the required safety valves (G).
4. If the system has the hot water circulation system, connect it to the connector pipe (L). Otherwise, plug the pipe.
5. Connect the supply (J) and return (H) of the heating medium to the coil.

### CAUTION

*If there is an electric heating module installed in the storage tank, fill the tank with water before connecting it to the electrical installation.*

### CAUTION

*Open the hot water intake valves before heating the system up for the first time or after a longer break in its operation in order to check whether the storage tank is filled with water and the cut-off valve at the cold water inlet is not closed.*

## Climate system

1. Open the vent at the top of the heating system.
2. Open all shut-off valves, where installed, so that water flows into all circuits.
3. Open the valve for filling the heating circuit and fill it with water.
4. Close the vent when water comes out continuously without bubbles.
5. Check the manometer and close the filling valve when the pressure reaches the required value (2bar is recommended).
6. Start the circulation pump of the heating system, and open the vent from time to time and release the all remaining air in the heating system.
7. Open safety valve until the pressure of the heating system drops down to about 1bar. If the pressure drops below 1bar during venting, add additional water in the circuit.

## Inspection of installation

Current regulations require that the climate system is inspected before it is commissioned. The inspection must be carried out by a suitably qualified person and must be documented. Do not replace any part of the system without carrying out new checks.



## Start-up and inspection

### Before start-up

- 1 In case of cascade connection, check if each indoor unit has a unique address. See Cascade connection setting on page 59 for details.
2. Start commissioning by the following steps.

### Commissioning with heat pump

Start guide is shown on the display on the controller when it is turned ON for the first time. Follow the start guide in the display, or choose menu 5.7 to show the start guide. For details, see Start guide on page 72.

### Commissioning with additional heater only

Follow the start guide in the display as same as commissioning with heat pump, and then follow the list below.

1. Go to menu 4.2 op. mode.
2. Mark "add. heat only" using the control knob and then press the OK button.
3. Return to the main menus by pressing the Back button.

### CAUTION

*When commissioning without MTH air/water heat pump an alarm communication error may appear in the display.  
The alarm is reset if the relevant heat pump is deactivated in menu 5.2.2 ("installed heat pump").*

### 3-way valve operation check

1. Activate "AA2-K1 (QN10)" in menu 5.6.
2. Check that the reversing valve opens or is open for hot water charging.
3. Deactivate "AA2-K1 (QN10)" in menu 5.6.

### AUX function check

To check any function connected to the AUX socket,

1. Activate "AA2-X4 (RC-HY20-W)" or "AA3-X7 (RC-HY40-W)" in menu 5.6.
2. Check the desired function.
3. Deactivate "AA2-X4 (RC-HY20-W)" or "AA3-X7 (RC-HY40-W)" in menu 5.6.

### Cooling mode

In case the climate system contains a cooling circuit, activate cooling function in menu 5.11.1.1. After that, you can choose cooling mode indication in menu 5.4 for the AUX output.

### Cleaning particle filter

Clean the particle filter (HQ1) after installation.

1. Close valve QM31 and the valve by the particle filter (HQ1).
2. Open the safety valve (QM20) to ensure that the pressure in HSB60-W drops.

3. Clean the particle filter (HQ1) as illustrated.

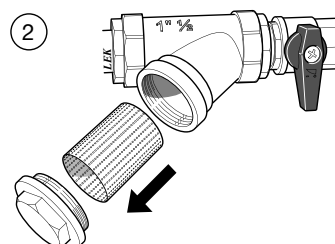
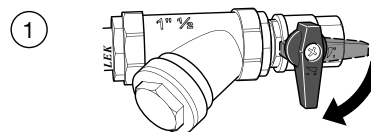

### Secondary adjustment

Air is initially released from the hot water and venting may be necessary. If bubbling sounds can be heard from the heat pump, the circulation pump and radiators the entire system will require further venting. When the system is stable (correct pressure and all air eliminated) the automatic heating control system can be set as required

## Start guide

### NOTE

Fill in the climate system with water before the switch is set to "I".

1. Set the control module's switch to "I".
2. Follow the instructions in the start guide in the control module display. If the start guide does not start when you start the control module, start it manually in menu 5.7.

### TIP

See page 82 for a more in-depth introduction to the installation's control system (operation, menus etc.).

## Commissioning

The start guide is displayed when installation is started. It describes what needs to carry out at the first start together with basic settings during installation.

The start guide is displayed so that it cannot be bypassed in order to carry out the start-up correctly. You can start the start guide later in menu 5.7.

During the start-up guide, reversing valves and the shunt are run back and forth to help vent the heat pump.

### CAUTION

As long as the start guide is active, no function in the heat pump will start automatically.  
Each time the controller is ON, the guide will appear until it is completed on the last page.

## Operation in the start guide

A. Page                      B. Name and menu number

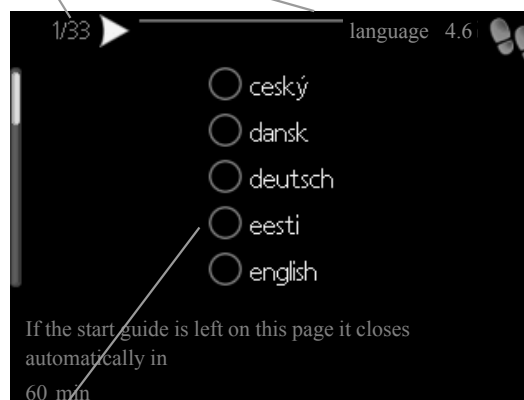

C. Option / setting

### A. Page

You can see the current page of the start guide.

Scroll between the pages of the start guide as follows:

1. Turn the control knob until the arrow is marked in the top left corner (at the page number).
2. Press OK button to proceed to the next page in the start guide.

### B. Name and menu number

You can see the menu name of this page. The number refers to the menu number in the control system.

To read more about affected menus, see the help menu or read the user manual.

### C. Option / setting

Make settings for the system here.

### D. Help menu

 In many menus there is a symbol indicating that extra help is available.

To access the help text:

1. Use the control knob to select the help symbol.
2. Press OK button.

The help text often consists of several windows that you can scroll between using the control knob.

### Start guide - RC-HY20-W

This menu is shown at the first time that the heat pump is started. It ensures that commissioning is carried out correctly and all necessary steps are followed.

The following menus are basic settings. If accessories are connected other menus will appear.

#### 1/18 - Language

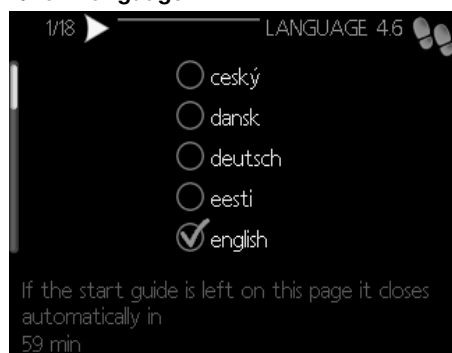

Select the language of the controller.

**Factory setting:** English

**Available languages:** Czech, Danish, German, Estonian, English, Spanish, French, Croatian, Icelandic, Italian, Latvian, Lithuanian, Hungarian, Dutch, Norwegian, Polish, Romanian, Russian, Slovenian, Finnish, Swedish, Turkish.

#### 2/18 - Start guide

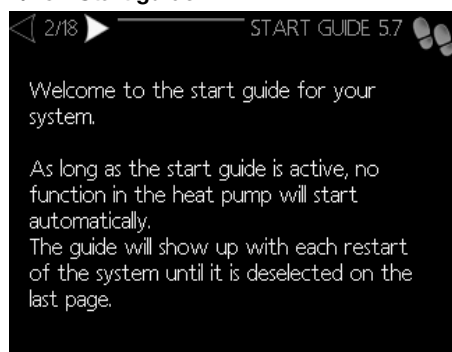

This menu displays information about the start guide.

No action needed.

#### 3/18 - Country

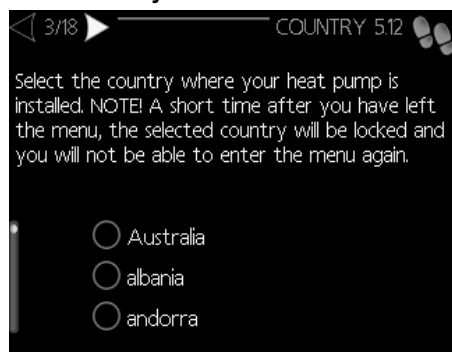

Select the country where your heat pump is located.

#### 4/18 - Flow set. climate sys.

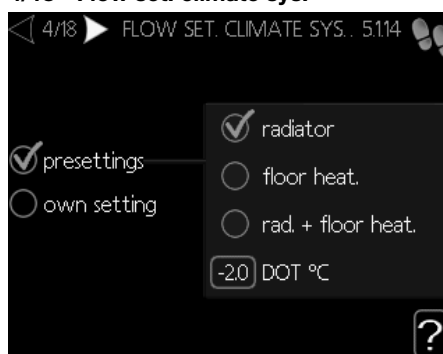

The type of heating distribution system the heating medium pump works towards is set here.

**Factory setting:** Presettings - Radiator

**Setting range:**

- **Presettings**
  - Radiator
  - Floor heating
  - Rad. + floor heat
- **Own setting**
  - Setting range dt at DOT: 0.0 - 25.0°C
  - Setting range DOT: -40.0 - 20.0°C

Where dt at DOT is the difference in degrees between the flow and return temperature at dimensioned outdoor temperature.

#### 5/18 - Accessories

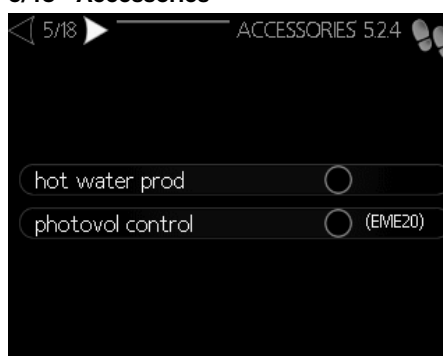

Activate additional connected accessories here.

**Setting range:** hot water prod, photovol control (EME20)

#### 6/18 - Soft in/outputs



Set the function of each input and output for each terminal (if connected)

**Setting range:**

- **Aux 1-6**
  - Temperature sensor, cooling/heating (BT74)
  - Temperature sensor, external return line (BT71)
  - Temperature sensor, flow line cooling (BT64)
  - Contact for external tariff blocking
  - Switch for "SG Ready"
  - Contact for activation of "external adjustment"
  - Switch for external alarm
  - Switch for external blocking
- **AA2-X4**
  - Alarm output
  - Cooling mode indication
  - Active cooling 4-pipe
  - External heating medium pump (GP10)
  - Hot water circulation (GP11)

**7/18 - Room sensor settings**



Activate and set the room temperature sensor RTS40M (if connected)

**8/18 - Start guide**



Check if the values of the shown temperature sensors are correct.

**9/18 - Addition**

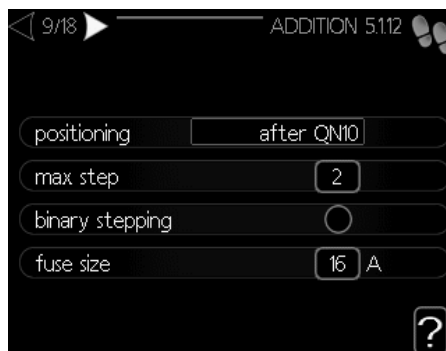

Set addition settings here.

**Factory setting:**

- **Positioning:** Before QN10
- **Max step:** 3
- **Fuse size:** 16A

**Setting range:**

- **Positioning:**
  - Before QN10
  - After QN10
- **Max step:**
  - Binary stepping deactivated: 0–3
  - Binary stepping activated: 0–7
- **Fuse size:** 11–200A

**10/18 - Installed heat pump**



Enable heat pump (EB101) here.

**11/18 - Time & date**



Set time, date and time zone here.

If the system is connected to myUpway then time and date are

set automatically.

**12/18 - Mln. flow line temperature**

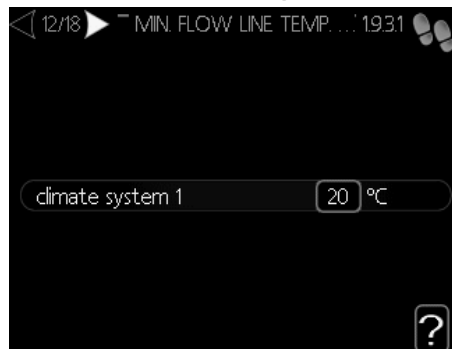

Set the minimum flow line temperature of the climate system.

**Factory setting:** 20°C

**Setting range:** 5–70°C

**13/18 - Max. flow line temperature**

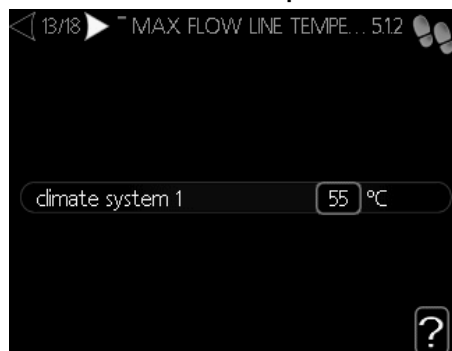

Set the maximum flow line temperature of the climate system.

**Factory setting:** 60°C

**Setting range:** 5–70°C

**14/18 - Heating curve**

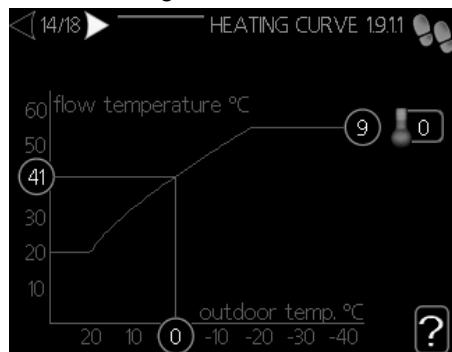

View and set (if desired) the space heating curve.

**15/18 - Op. mode**

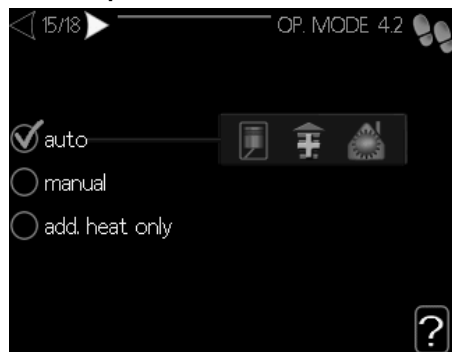

Set the operating mode of the heat pump.

**Factory setting:** Auto

**Setting range:**

- Auto
- Manual
  - Heating
  - Cooling
  - Add. heat only
- Add. heat only
  - Heating

**16/18 - Alarm actions**

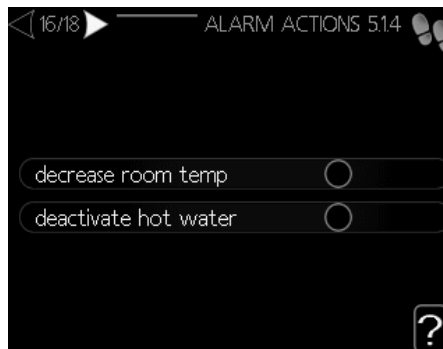

Set how to control the heat pump in case of alarm.

**17/18 - Start guide**

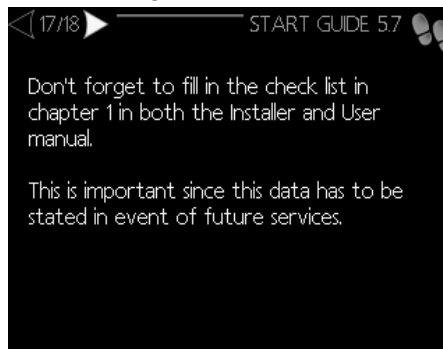

Information message from the controller. No action needed.

**18/18 - Start guide**

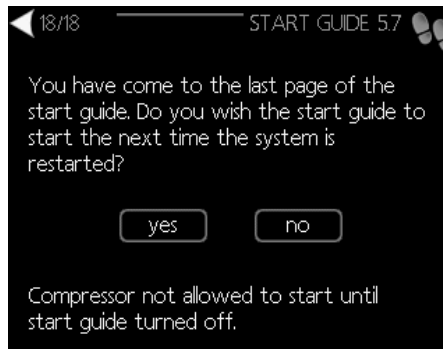

Commissioning guide finishes here. You can set it to open again upon restart of the controller or do not open it anymore.

### Start guide - RC-HY40-W

This menu is shown at the first time that the heat pump is started. It ensures that commissioning is carried out correctly and all necessary steps are followed.

The following menus are basic settings. If accessories are connected other menus will appear.

#### 1/19 - Language

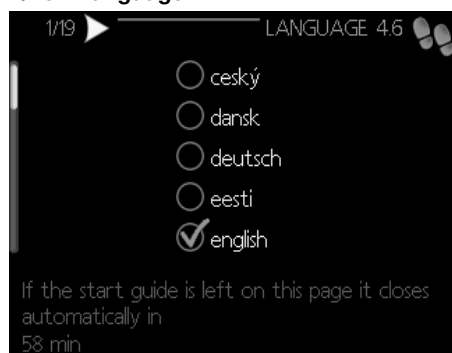

Select the language of the controller.

**Factory setting:** English

**Available languages:** Czech, Danish, German, Estonian, English, Spanish, French, Croatian, Icelandic, Italian, Latvian, Lithuanian, Hungarian, Dutch, Norwegian, Polish, Romanian, Russian, Slovenian, Finnish, Swedish, Turkish.

#### 2/19 - Start guide

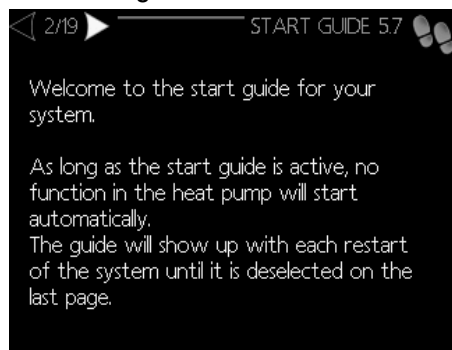

This menu displays information about the start guide.

No action needed.

#### 3/19 - Country

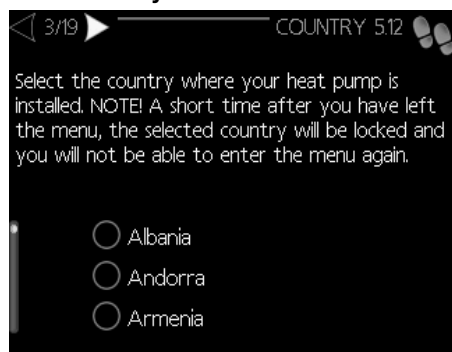

Select the country where your heat pump is located.

#### 4/19 - Flow set. climate sys.

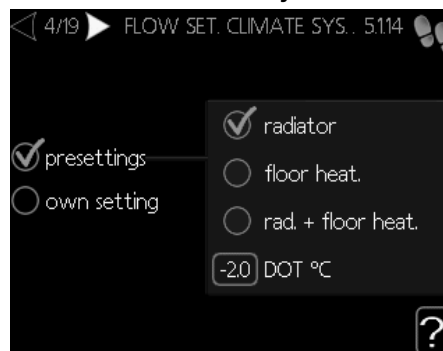

The type of heating distribution system the heating medium pump works towards is set here.

**Factory setting:** Presettings - Radiator

**Setting range:**

- **Presettings**
  - Radiator
  - Floor heating
  - Rad. + floor heat
- **Own setting**
  - Setting range dt at DOT: 0.0–25.0°C
  - Setting range DOT: -40.0–20.0°C

Where dt at DOT is the difference in degrees between the flow and return temperature at dimensioned outdoor temperature.

#### 5/19 - Accessories

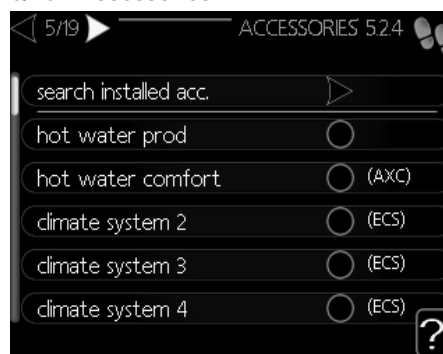

Activate or search for additional connected accessories here.

#### 6/19 - Soft in/outputs

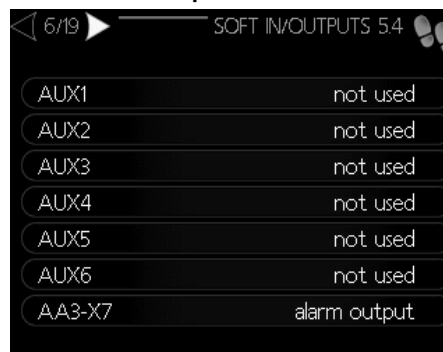

Set the function of each input and output for each terminal (if connected)

**Setting range:**

- **Aux 1-6**
  - Temperature sensor, cooling/heating (BT74)
  - Temperature sensor, heating supply downstream the submersible heater (BT63)
  - Temperature sensor, flow line cooling (BT64)
  - Temperature sensor, boiler (BT52)
  - Contact for external tariff blocking
  - Switch for "SG Ready"
  - Contact for activation of "external adjustment"
  - Switch for external alarm
  - Switch for external blocking
- **AA3-X7**
  - Alarm output
  - Cooling mode indication
  - Active cooling 4-pipe
  - External heating medium pump (GP10)
  - Hot water circulation (GP11)

**7/19 - Room sensor settings**



Activate and set the room temperature sensor RTS40M (if connected) for each climate system

**8/19 - Start guide**

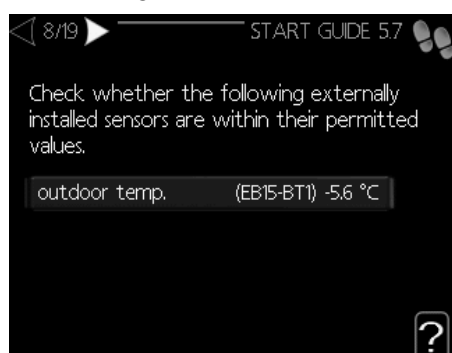

Check if the values of the shown temperature sensors are correct.

**9/19 - Addition**

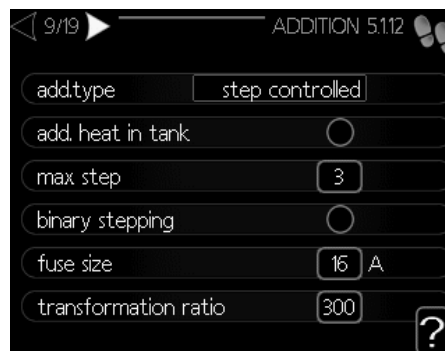

Set addition settings here.

**Factory setting:**

- **Positioning:** Before QN10
- **Max step:** 3
- **Fuse size:** 16A
- **Transformation ration:** 16A

**Setting range:**

- **Add. tupe:**
  - step controlled
  - shunt controlled
- **Positioning:**
  - Before QN10
  - After QN10
- **Max step:**
  - Binary stepping deactivated: 0–3
  - Binary stepping activated: 0–7
- **Fuse size:** 11–200A
- **Transformtion ratio:** 300–3000

**10/19 - Installed slaves**

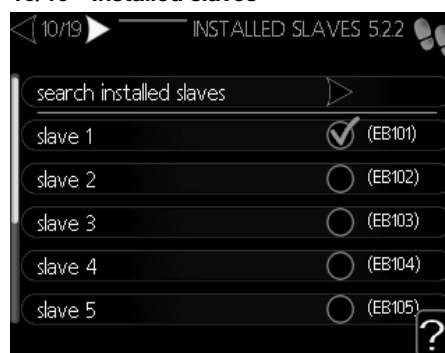

Search for installed slaves and enable them (if connected) here. If everything is correct the units are automatically selected after searching for installed slaves.

**11/19 - Docking**

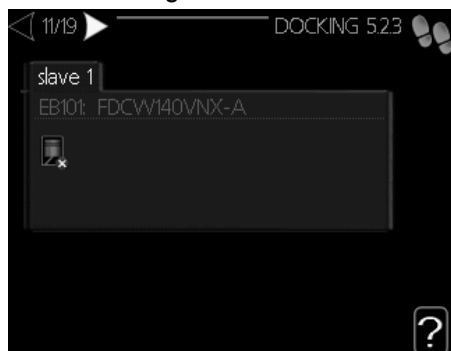

Set docking for each slave (if installed).

**12/19 - Time & date**



Set time, date and time zone here.

If the system is connected to myUpway then time and date are set automatically.

**13/19 - Min. flow line temperature**

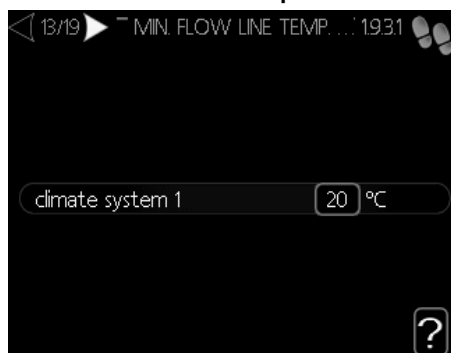

Set the minimum flow line temperature of the climate system.

**Factory setting:** 20°C

**Setting range:** 5–70°C

**14/19 - Max. flow line temperature**

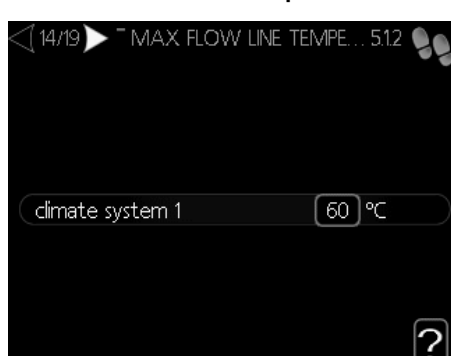

Set the maximum flow line temperature of the climate system.

**Factory setting:** 60°C

**Setting range:** 5–70°C

**15/19 - Heating curve**

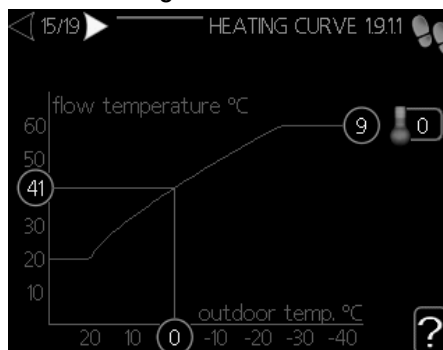

View and set (if desired) the space heating curve.

**16/19 - Op. mode**

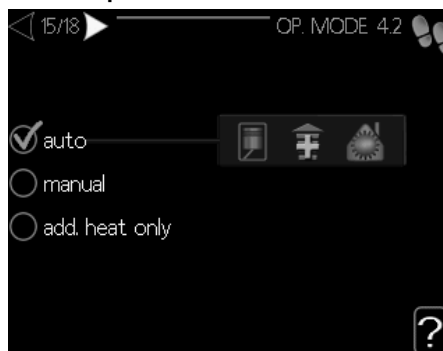

Set the operating mode of the heat pump.

**Factory setting:** Auto

**Setting range:**

- Auto
- Manual
  - Heating
  - Cooling
  - Add. heat only
- Add. heat only
  - Heating

**17/19 - Alarm actions**

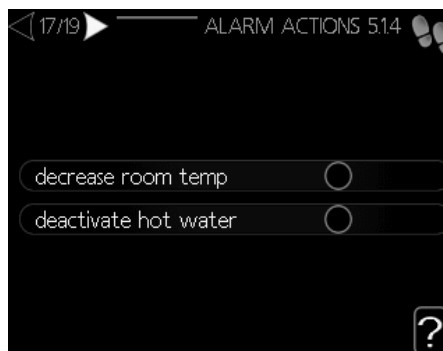

Set how to control the heat pump in case of alarm.



**18/19 - Start guide**

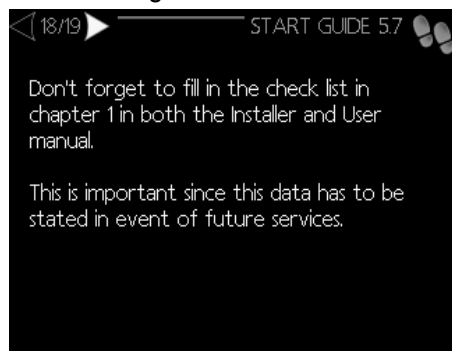

Information message from the controller. No action needed.

**19/19 - Start guide**

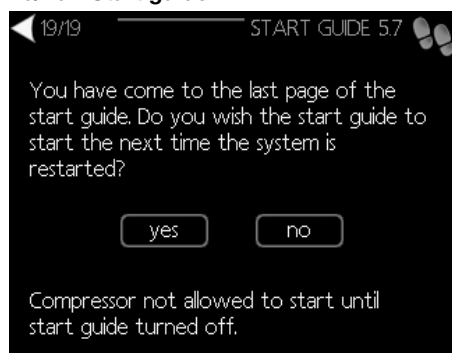

Commissioning guide finishes here. You can set it to open again upon restart of the controller or do not open it anymore.

## Heating/cooling curve setting

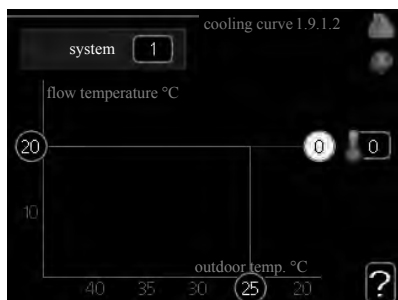
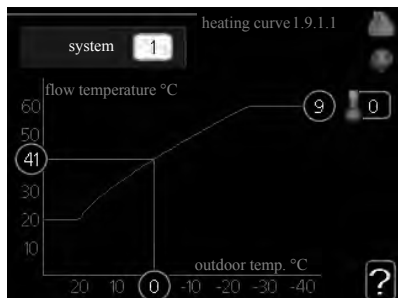

### heating curve

Setting range: 0 – 15

Default value: 9

### cooling curve (accessory required)

Setting range: 0 – 9

Default value: 0

The prescribed heating curve for your house can be viewed in the menu heating curve . The task of the heating curve is to give an even indoor temperature, regardless of the outdoor temperature, and thereby energy efficient operation. From this heating curve, the control module determines the temperature of the water to the heating system, supply temperature, and there by the indoor temperature. Select the heating curve and read off how the supply temperature changes at different outdoor temperatures here. If there is cooling function, the same settings can be made for the cooling curve.

### Curve coefficient

The heating/cooling curve shows the relation between the target supply temperature and the corresponding outdoor temperature. A steep curve indicates that supply temperature becomes higher at low outdoor air temperature in heating and it becomes lower at high outdoor air temperature in cooling.

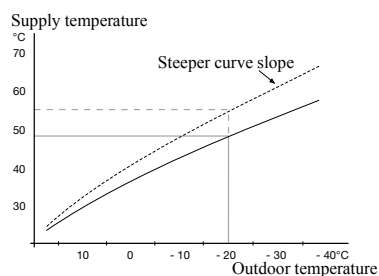

The optimum slope depends on the climate conditions in your location, the type of heating device (radiators or under floor heating) and how well insulated the house is.

The curve is set when the heating installation is installed, but may need adjusting later. Normally, the curve will not need further adjustment.

### CAUTION

*In the event of making fine adjustments of the indoor temperature, the curve must be offset up or down instead, this is done in menu 1.1 temperature.*

### Curve offset

The target temperature can be offset in parallel over the entire outdoor temperature range by this function. This is offset by 5 °C by adjusting 2 steps.

The target temperature can be parallel offset in the entire outdoor temperature range with this function. It is offset by 5 °C by adjusting 2 steps.

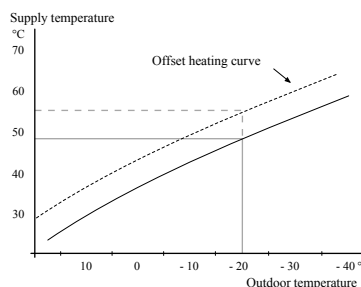

### Flow line temperature – maximum and minimum values

This function is used in order to limit max-min supply temperature. The heating / cooling curve becomes flat beyond max / min target temperature.

### CAUTION

*Underfloor heating systems are normally max flow line temperature set between 35 and 45°C. Take care not to cause low temperature burns in case it is set higher than 35°C.*

*Must be restricted with underfloor cooling min. flow line temperature to prevent condensation.*

*Check the max temperature for your floor with your installer/floor supplier.*

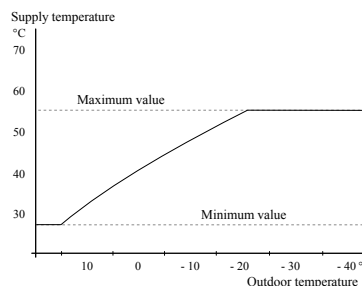

The figure at the end of the curve indicates the curve number. The figure beside the thermometer icon gives the curve offset. Use the control knob to set a new value.

Confirm the new setting by pressing the OK button.

Curve 0 is an own curve created in menu 1.9.7.

### To select another curve (slope):

1. Press OK button to access the setting mode
2. Select a new curve. The curves are numbered from 0 to 15, and the bigger number curve has steeper slope.  
Curve 0 means that own curve (menu 1.9.7) is used.
3. Press OK button to exit the setting.

### To read off a curve:

1. Turn the control knob so that the ring on the shaft with the outdoor temperature is marked.
2. Press OK button.
3. Follow the grey line up to the curve and out to the left to read off the value for the supply temperature at the selected outdoor temperature.
4. You can now select to take read outs for different outdoor temperatures by turning the control knob to the right or left and read off the corresponding flow temperature.
5. Press OK or Back button to exit read off mode.

### TIP

*Wait 24 hours before making a new setting, so that the room temperature has time to stabilise.*

*If it is cold outdoors and the room temperature is too low, increase the curve slope by one increment.*

*If it is cold outdoors and the room temperature is too high, lower the curve slope by one increment.*

*If it is warm outdoors and the room temperature is too low, increase the curve offset by one increment.*

*If it is warm outdoors and the room temperature is too high, lower the curve offset by one increment.*

## Hot water circulation setting

### hot water recirc.

#### **operating time**

Setting range: 1 – 60 min

Default value: 60 min

#### **downtime**

Setting range: 0 – 60 min

Default value: 0 min

Set the hot water circulation for up to three periods per day here. During the set periods the hot water circulation pump will run according to the settings above.

"operating time" decide how long the hot water circulation pump must run per operating instance.

"downtime" decide how long the hot water circulation pump must be stationary between operating instances.

Hot water circulation is activated in menu 5.4 "soft inputs and outputs".

## SG Ready

This function can only be used in mains networks that support the "SG Ready"-standard .

Make settings for the function "SG Ready" here.

Low price mode means that the electricity supplier has a low tariff and the system uses this to reduce costs.

Over capacity mode means that the electricity supplier has set the tariff very low and the system uses this to reduce the costs as much as possible.

### affect room temperature

Here you set whether room temperature should be affected when activating "SG Ready".

With low price mode of "SG Ready" the parallel offset of the indoor temperature is increased by "+1". If a room sensor is installed and activated, the desired room temperature increases by 1 °C.

With over capacity mode of "SG Ready" the parallel offset for the indoor temperature is increased by "+2".

If a room sensor is installed and activated, the desired room temperature increases by 2 °C.

### affect hot water

Here you set whether the temperature of the hot water should be affected when activating "SG Ready".

With low price mode on "SG Ready" the stop temperature of the hot water is set as high as possible at only compressor operation (immersion heater not permitted).

With over capacity mode of "SG Ready" the hot water is set to "luxury" (immersion heater permitted).

### affect cooling (accessory required)

Here you set whether room temperature during cooling operation should be affected when activating "SG Ready".

With low price mode of "SG Ready" and cooling operation the indoor temperature is not affected.

With over capacity mode of "SG Ready" and cooling operation the parallel offset for the indoor temperature is reduced by "-1". If a room sensor is installed and activated, the desired room temperature decreases by 1 °C.

## NOTE

*The function must be connected to two AUX inputs and activated in menu 5.4.*

# Control

## Control Display unit

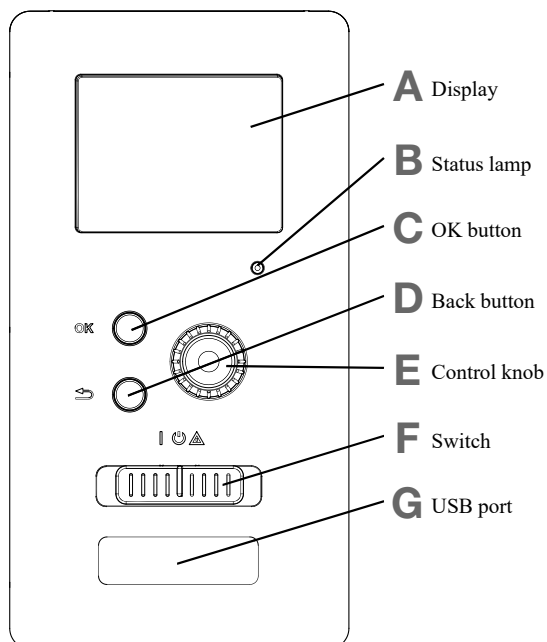

### A Display

Instructions, settings and operational information are shown on the display. The easy-to-read display and menu system, make it easy to navigate between various menus and options, set comfort and get the necessary information.

### B Status lamp

The status lamp indicates the status of the control module. It:

- lights green during normal operation.
- lights yellow in emergency mode.
- lights red in the event of an alarm.

### C OK button

The OK button is used to:

- confirm selections of sub menus/options/set values/page in the start guide.

### D Back button

The back button is used to:

- go back to the previous menu.
- change a setting that has not been confirmed.

### E Control knob

The control knob can be turned to the right or left. You can:

- scroll in menus and between options.
- increase and decrease values.
- change pages in multiple page instructions (for example help text and service info).

### F Switch (SF1)

The switch shows three positions:

- On ( I )
- Standby ( ⏻ )
- Emergency mode ( ⚠ )

Emergency mode must only be used in the event of a fault on the control module. In this mode, the compressor in the heat pump is turned off and the immersion heater is activated.

The control module display is not illuminated and the status lamp lights yellow.

### G USB port

The USB port is hidden behind the plastic badge of the product name.

The USB port is used to update the software.

## Menu system

### RC-HY20-W

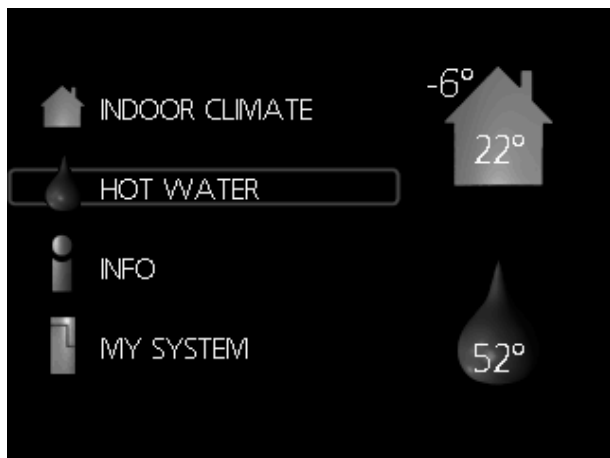

### RC-HY40-W

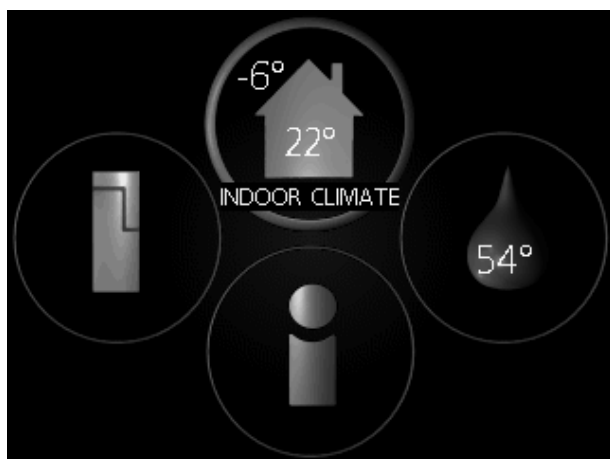

#### Menu 1 - INDOOR CLIMATE

Setting and scheduling the indoor climate. See information in the help menu or user manual.

#### Menu 2 - HOT WATER

Setting and scheduling hot water production. See information in the help menu or user manual.

This menu only appears if a water heater is installed in the system.

#### Menu 3 - INFO

Display of temperature and other operating information and access to the alarm log. See information in the help menu or user manual.

## Symbols in the display

The following symbols can appear in the display during operation.

Symbol	Description
	This symbol appears when there is information to be noticed in menu 3.1.
	<p>These two symbols indicate whether the compressor in the outdoor unit or additional heat in the installation is blocked via controller.</p> <p>These functions will be blocked for example, when either of the operation mode is blocked in menu 4.2, when blocking of either function is scheduled in menu 4.9.5, or when an alarm for blocking the operation occurs.</p>
	Blocking the compressor.
	Blocking additional heat.
	This symbol appears if periodic increase or lux mode for the hot water is activated.
	This symbol indicates if "holiday setting" is active in menu 4.7.
	This symbol indicates if the controller has contact with myUpway.
	This symbol indicates if cooling is active.

#### Menu 4 - MY INSTALLATION

Setting time, date, language, display, operating mode etc. See information in the help menu or user manual.

#### Menu 5 - SERVICE

Advanced settings. These settings are not available to the end user. The menu is made visible by pressing the Back button for 7 seconds in the top screen.

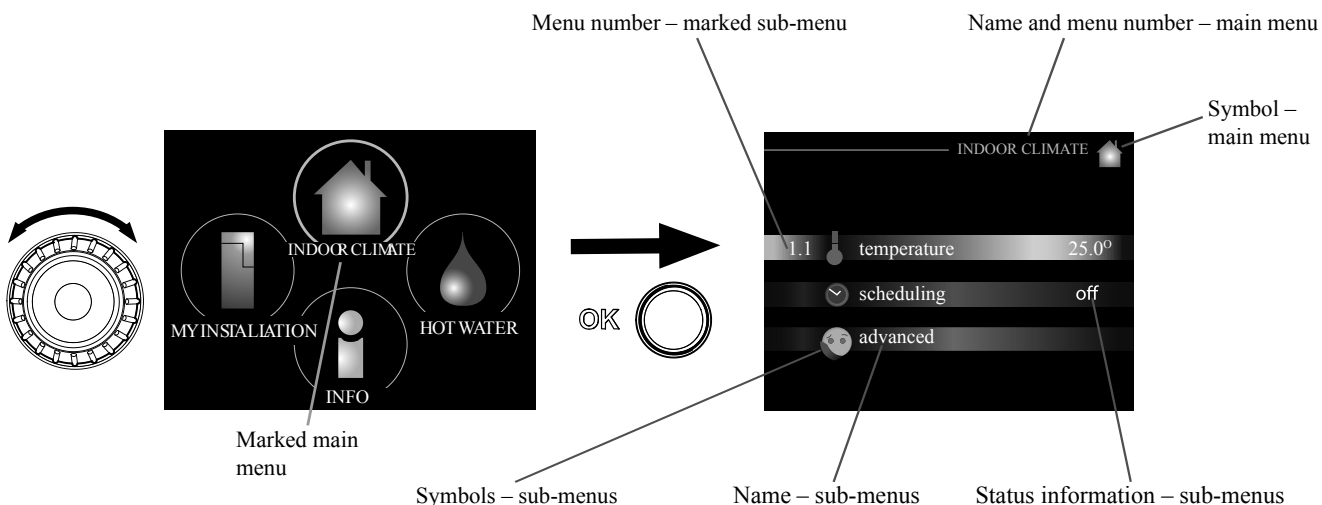

### Operation

To move the cursor, turn the control knob to the left or the right. The marked position is brighter and/or has a light frame.

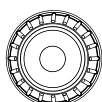

### Selecting menu

To advance in the menu system select a main menu by marking it and then pressing the OK button. A new window opens with sub menus.

Select one of the sub menus by marking it and then pressing the OK button.

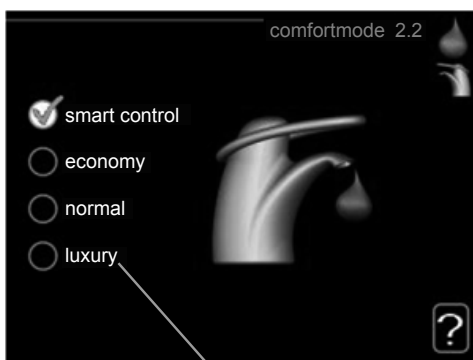

### Selecting options



Alternative

In an options menu the current selected option is indicated by a green tick. 

To select another option:



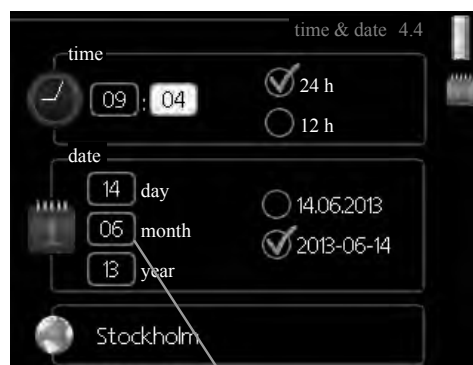

1. Mark the applicable option. One of the options is pre-selected (white). 
2. Press the OK button to confirm the selected option. The selected option has a green tick. 

### Setting a value



Values to be changed

To set a value:

1. Mark the value you want to set using the control knob. 
2. Press the OK button. The background of the value becomes green, which means that you have accessed the setting mode. 
3. Turn the control knob to the right to increase the value and to the left to reduce the value. 
4. Press the OK button to confirm the value you have set. To change and return to the original value, press the Back button. 



### Use the virtual keyboard

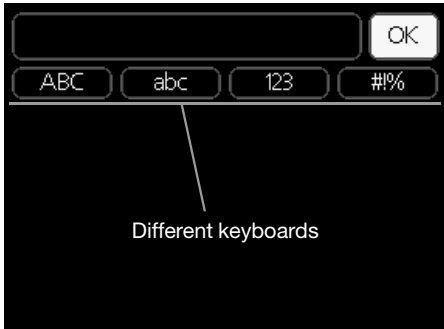

In some menus where text may require entering, a virtual keyboard is available.



Depending on the menu, you can gain access to different character sets which you can select using the control knob. To change character table, press the Back button. If a menu only has one character set, the keyboard is displayed directly.

When you have finished writing, mark "OK" and press the OK button.

### Scroll through the windows

A menu can consist of several windows. Turn the control knob to scroll between the windows.

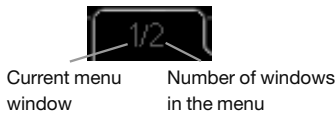

### Scroll through the windows in the start guide

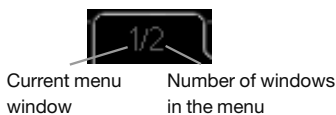

1. Turn the control knob until one of the arrows in the top left corner (at the page number) has been marked.
2. Press the OK button to skip between the steps in the start guide.

### Help menu

**?** In many menus there is a symbol that indicates that extra help is available.

To access the help text:

1. Use the control knob to select the help symbol.
2. Press the OK button.

The help text often consists of several windows that you can scroll between using the control knob.

## Menu list

\*\* Accessories are needed. \*\* Heat pump with cooling function required. 40"

MENU		RC-HY20-W	RC-HY40-W		
<b>1 INDOOR CLIMATE</b>					
1.1 - temperature	1.1.1 heating	✓	✓		
	1.1.2 cooling **	✓	✓		
1.3 - scheduling	1.3.1 heating	✓	✓		
	1.3.2 cooling **	✓	✓		
1.9 - advanced	1.9.1 curve	1.9.1.1 heating curve	✓	✓	
		1.9.1.2 cooling curve **	✓	✓	
	1.9.2 external adjustment		✓	✓	
	1.9.3 min. flow line temp.	1.9.3.1 heating	✓	✓	
		1.9.3.2 cooling **	✓	✓	
	1.9.4 room sensor settings		✓	✓	
	1.9.5 cooling settings *		✓	✓	
	1.9.7 own curve	1.9.7.1 heating	✓	✓	
		1.9.7.2 cooling **	✓	✓	
1.9.8 point offset		✓	✓		
<b>2 HOTWATER</b>					
2.1 temporary lux		✓	✓		
2.2 comfort mode		✓	✓		
2.3 scheduling		✓	✓		
2.9 advanced	2.9.1 periodic increase	✓	✓		
	2.9.2 hot water recirc. *	✓	✓		
<b>3 INFO</b>					
3.1 service info		✓	✓		
3.2 compressor info		✓	✓		
3.3 add. heat info		✓	✓		
3.4 alarm log		✓	✓		
3.5 indoor temp. log		✓	✓		
<b>4. MY SYSTEM</b>					
4.1 plus functions	4.1.1 Pool 1		—	✓	
	4.1.2 Pool 2		—	✓	
	4.1.3 internet	4.1.3.1 myUpway™	✓	✓	
		4.1.3.8 tcp/ip settings	✓	✓	
		4.1.3.9 proxy settings	✓	✓	
	4.1.5 SG Ready		✓	✓	
	4.1.6 smart price adaption™		✓	✓	
	4.1.8 smart energy source™	4.1.8.1 settings		—	✓
		4.1.8.2 set. Price		—	✓
		4.1.8.3 CO2 impact		—	✓
4.1.8.4 tariff periods, electricity		—	✓		
4.1.8.6 tariff per, ext. shunt add		—	✓		

\*\* Accessories are needed. \*\* Heat pump with cooling function required. 40"

MENU		RC-HY20-W	RC-HY40-W
	4.1.8.7 tariff per, ext. step add	—	✓
	4.1.10 Solar electricity	✓	✓
4.2 op. mode		✓	✓
4.3 my icons		✓	✓
4.4 time & date		✓	✓
4.6 language		✓	✓
4.7 holiday setting		✓	✓
4.9 advanced	4.9.1 op. prioritisation	✓	✓
	4.9.2 auto mode setting	✓	✓
	4.9.3 degree minute setting	✓	✓
	4.9.4 factory setting user	✓	✓
	4.9.5 schedule blocking	✓	✓
	4.9.6 schedule silent mode	✓	✓
<b>5 SERVICE</b>			
5.1 operating settings	5.1.1 hot water settings *	✓	✓
	5.1.2 max flow line temperature	✓	✓
	5.1.3 max diff flow line temp.	✓	✓
	5.1.4 alarm actions	✓	✓
	5.1.12 addition	✓	✓
	5.1.14 flow set. climate system	✓	✓
	5.1.22 heat pump testing	✓	✓
	5.1.23 compressor curve	✓	✓
5.2 system settings	5.2.2 installed slaves	✓	✓
	5.2.3 docking	✓	✓
	5.2.4 accessories	✓	✓
5.3 accessory settings	5.3.2 shunt controlled add. heat *	—	✓
	5.3.3 extra climate system *	—	✓
	5.3.4 solar heating *	—	✓
	5.3.6 step controlled add. heat	—	✓
	5.3.8 hot water comfort *	—	✓
	5.3.10 modbus *	—	✓
	5.3.20 flow sensor*	—	✓
5.4 soft in/outputs		✓	✓
5.5 factory setting service		✓	✓
5.6 forced control		✓	✓
5.7 start guide		✓	✓
5.8 quick start		✓	✓
5.9 floor drying function		✓	✓
5.10 change log		✓	✓

"\* Accessories are needed. \*\* Heat pump with cooling function required. 40"

MENU		RC-HY20-W	RC-HY40-W
5.11 slave settings	5.11.1 EB101	5.11.1.1 heat pump	✓
		5.11.1.2 charge pump (GP12)	✓
	5.11.2 EB102	—	✓
	5.11.3 EB103	—	✓
	5.11.4 EB104	—	✓
	5.11.5 EB105	—	✓
	5.11.6 EB106	—	✓
	5.11.7 EB107	—	✓
	5.11.8 EB108	—	✓
5.12 country		✓	✓

## RC-HY20/40-W – at your service

### Set the indoor climate

#### Overview

#### Sub-menus



For the menu "INDOOR CLIMATE" there are several sub-menus. Status information for the relevant menu can be found on the display to the right of the menus.

**"temperature"** Setting the temperature for the climate system. The status information shows the set values for the climate system.

**"scheduling"** Scheduling heating and cooling. Status information "set" is displayed if you set a schedule but it is not active now, "holiday setting" is displayed if the vacation schedule is active at the same time as the schedule (the vacation function is prioritised), "active" displays if any part of the schedule is active, otherwise it displays " off".

**"advanced"** Setting of heat curve, adjusting with external contact, minimum value for supply temperature, room sensor and cooling function.

#### Menu 1.1 - temperature

If the house has several climate systems, this is indicated on the display by a thermometer for each system.

Choose heating or cooling and then set the desired temperature in the next menu "temperature heating/cooling" in menu 1.1.

#### Set the temperature (with room sensors installed and activated):

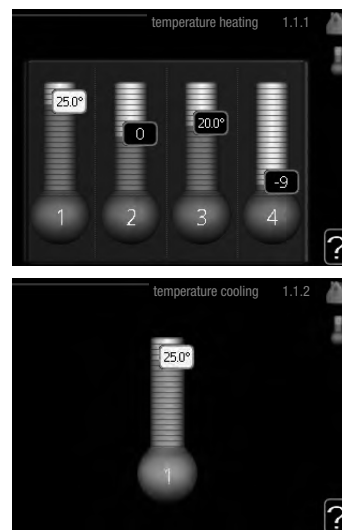

#### heating

Setting range: 5 – 30 °C

Default value: 20

#### cooling (accessory is required)

Setting range: 5 – 30 °C

Default value: 25

The value in the display appears as a temperature in °C if the climate system is controlled by a room sensor.

### CAUTION

*A slow heat-releasing heating system, such as for example, underfloor heating, may not be suitable for control using the heat pump's room sensor.*

To change the room temperature, use the control knob to set the desired temperature in the display. Confirm the new setting by pressing the OK button. The new temperature is shown on the right-hand side of the symbol in the display.

#### Setting the temperature (without room sensors activated):

Setting range: -10 to +10

Default value: 0

The display shows the set values for heating (curve offset). To increase or reduce the indoor temperature, increase or reduce the value on the display.

Use the control knob to set a new value. Confirm the new setting by pressing the OK button.

The number of steps the value has to be changed to achieve a degree change of the indoor temperature depends on the heating installation. One step is usually enough but in some cases several steps may be required.

The new value is shown on the right-hand side of the symbol in the display.

**CAUTION**

*An increase in the room temperature can be slowed by the thermostats for the radiators or under floor heating. Therefore, open the thermostats fully, except in those rooms where a cooler temperature is required, e.g. bedrooms.*

**TIP**

*Wait 24 hours before making a new setting, so that the room temperature has time to stabilise.*

*If it is cold outside temperature and the room temperature is too low, increase the curve slope in menu 1.9.1.1 by one increment.*

*If it is cold outside temperature and the room temperature is too high, reduce the curve slope in menu 1.9.1.1 by one increment.*

*If it is warm outside temperature and the room temperature is too low, increase the value in menu 1.1.1 by one increment.*

*If it is warm outside temperature and the room temperature is too high, reduce the value in menu 1.1.1 by one increment.*

**Menu 1.3 - temperature scheduling**

In the menu scheduling indoor climate (heating/cooling) is scheduled for each weekday.

You can also schedule a longer period during a selected period (vacation) in menu 4.7.

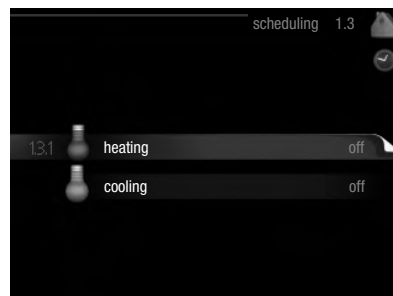

**Menu 1.3.1 - heating**

Increases or decreases in the accommodation temperature can be scheduled here for up to three time periods per day. One step is usually enough to change the room temperature by one degree, but in some cases several steps may be required for the accommodation temperature.

If a room sensor is installed and activated, the desired room temperature (°C) is set during the time periods.

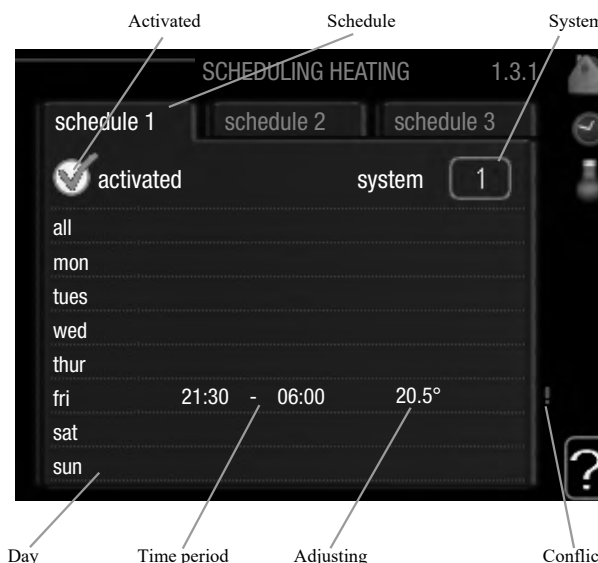

**Schedule:** The schedule to be changed is selected here.

**Activated:** Scheduling for the selected period is activated here. Set times are not affected at deactivation.

**System (RC-HY40-W only):** Which climate system the schedule is for is selected here. This alternative is only displayed if more than one climate system is present.

**Day:** Select which day or days of the week the schedule is to apply to here. To remove the scheduling for a particular day, the time for that day must be reset by setting the start time to the same as the stop time. If the line "all" is used, all days in the period are set for these times.

**Time period:** The start and stop time for the selected day for scheduling are selected here.

**Adjusting:** How much the heating curve is to be offset in relation to menu 1.1 during scheduling is set here. If the rooms sensor is installed and activated, the desired room temperature is set in °C.

**Conflict:** If two settings conflict with each other a red exclamation mark is displayed.

**TIP**

*If you wish to set similar scheduling for every day of the week start by filling in "all" and then changing the desired days.*

**TIP**

*Set the stop time earlier than the start time so that the period extends beyond midnight. Scheduling then stops at the set stop time the day after.  
Scheduling always starts on the date that the start time is set for.*

**CAUTION**

*Changes of temperature in accommodation take time. For example, short time periods in combination with underfloor heating will not give a noticeable difference in room temperature.*

**Time period:** The start and stop time for the selected day for scheduling are selected here.

**Adjusting:** Here, you set when active cooling will not be permitted.

**Conflict:** If two settings conflict with each other a red exclamation mark is displayed.

**TIP**

*If you wish to set similar scheduling for every day of the week start by filling in "all" and then changing the desired days.*

**TIP**

*Set the stop time earlier than the start time so that the period extends beyond midnight. Scheduling then stops at the set stop time the day after.  
Scheduling always starts on the date that the start time is set for.*

**Menu 1.3.2 - cooling**

Here you can schedule when cooling is permitted in the accommodation for up to two different time periods per day.

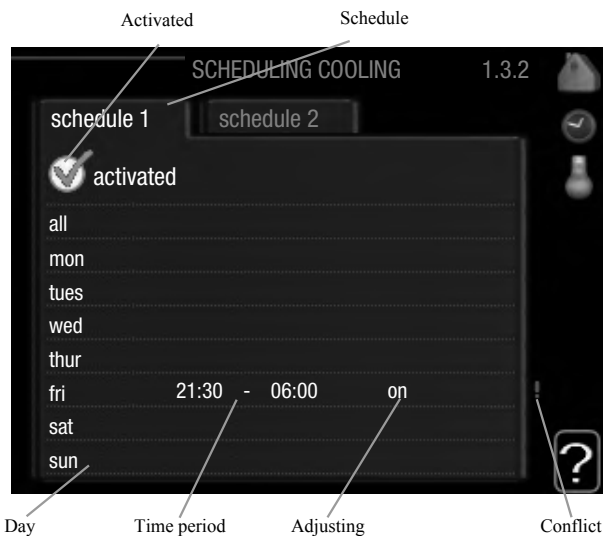

**Schedule:** The schedule to be changed is selected here.

**Activated:** Scheduling for the selected period is activated here. Set times are not affected at deactivation.

**Day:** Select which day or days of the week the schedule is to apply to here. To remove the scheduling for a particular day, the time for that day must be reset by setting the start time to the same as the stop time. If the line "all" is used, all days in the period are set for these times.

**Menu 1.9 - advanced**

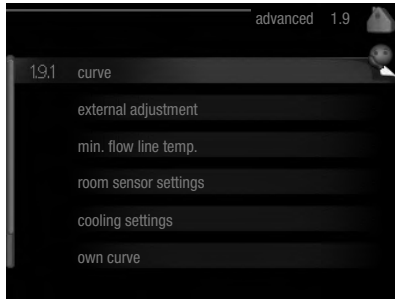

Menu "advanced" has orange text and is intended for the advanced user. This menu has several sub-menus.

- "**curve**" Setting the curve slope for heating and cooling.
- "**external adjustment**" Setting the heat curve offset when the external contact is connected.
- "**min. flow line temp.**" Setting minimum permitted flow line temperature.
- "**room sensor settings**" Settings regarding the room sensor.
- "**cooling settings**" Settings for cooling.
- "**own curve**" Setting own curve for heating and cooling.
- "**point offset**" Setting the offset of the heating curve or cooling curve at a specific outdoor temperature.

**Menu 1.9.1 - Heating/cooling curve setting**

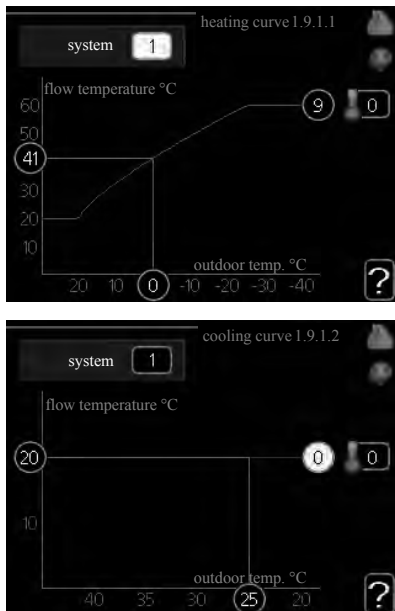

**heating curve**

Setting range: 0 – 15  
Default value: 9

**cooling curve (accessory required)**

Setting range: 0 – 9  
Default value: 0

The prescribed heating curve for your house can be viewed in the menu "heating curve". The task of the heating curve is to give an even indoor temperature, regardless of the outdoor temperature, and thereby energy efficient operation. From this heating curve, the control module determines the temperature of the water to the heating system, supply temperature, and therefore the indoor temperature. Select the heating curve and read off how the supply temperature changes at different outdoor temperatures here. If there is cooling function, the same settings can be made for the cooling curve.

**Curve coefficient**

The heating/cooling curve shows the relation between the target supply temperature and the corresponding outdoor temperature. A steep curve indicates that supply temperature becomes higher at low outdoor air temperature in heating and it becomes lower at high outdoor air temperature in cooling.

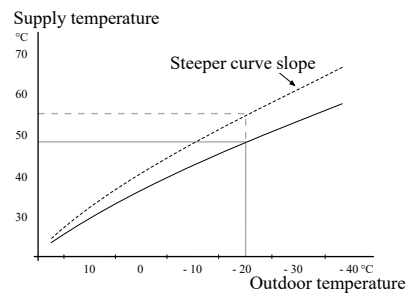

The optimum slope depends on the climate conditions in your location, the type of heating device (radiators or under floor heating) and how well insulated the house is.

The curve is set when the heating installation is installed, but may need adjusting later. Normally, the curve will not need further adjustment.

**CAUTION**

*In the event of making fine adjustments of the indoor temperature, the curve must be offset up or down instead, this is done in menu 1.1 "temperature".*

**Curve offset**

The target temperature can be offset in parallel over the entire outdoor temperature range by this function. This is offset by 5 °C by adjusting 2 steps.

The target temperature can be parallel offset in the entire outdoor temperature range with this function. It is offset by 5 °C by adjusting 2 steps.

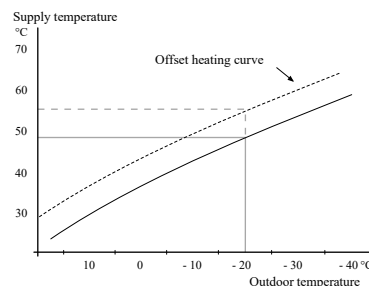



**Flow line temperature – maximum and minimum values**

This function is used in order to limit max-min supply temperature. The heating / cooling curve becomes flat beyond max / min target temperature.

**CAUTION**

*Underfloor heating systems are normally "max flow line temperature" set between 35 and 45°C. Take care not to cause low temperature burns in case it is set higher than 35°C.*

*Must be restricted with underfloor cooling min. flow line temp. to prevent condensation.*

*Check the max temperature for your floor with your installer/floor supplier.*

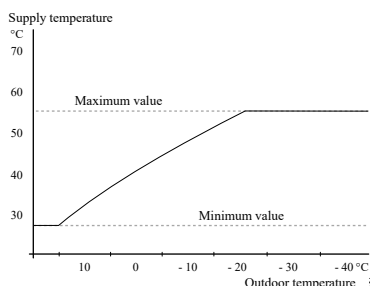

The figure at the end of the curve indicates the curve number. The figure beside the thermometer icon gives the curve offset. Use the control knob to set a new value.

Confirm the new setting by pressing the OK button.

Curve 0 is an own curve created in menu 1.9.7.

**To select another curve (slope):**

1. Press OK button to access the setting mode
2. Select a new curve. The curves are numbered from 0 to 15, and the bigger number curve has steeper slope. Curve 0 means that "own curve" (menu 1.9.7) is used.
3. Press OK button to exit the setting.

**To read off a curve:**

1. Turn the control knob so that the ring on the shaft with the outdoor temperature is marked.
2. Press OK button.
3. Follow the grey line up to the curve and out to the left to read off the value for the supply temperature at the selected outdoor temperature.
4. You can now select to take read outs for different outdoor temperatures by turning the control knob to the right or left and read off the corresponding flow temperature.
5. Press OK or Back button to exit read off mode.

**TIP**

- Wait 24 hours before making a new setting, so that the room temperature has time to stabilise.*
- If it is cold outdoors and the room temperature is too low, increase the curve slope by one increment.*
- If it is cold outdoors and the room temperature is too high, lower the curve slope by one increment.*
- If it is warm outdoors and the room temperature is too low, increase the curve offset by one increment.*
- If it is warm outdoors and the room temperature is too high, lower the curve offset by one increment.*

**Menu 1.9.2 - external adjustment**

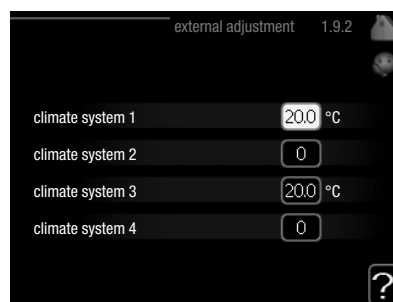

\*If there is one climate system, display shows "climate system 1" only.

**climate system**

Setting range: -10 to +10 or desired room temperature if the room sensor is installed.

Default value: 0

Connecting an external contact, for example, a room thermostat or a timer allows you to temporarily or periodically increase or decrease the room temperature while heating. When the contact is on, the heating curve offset is changed by the number of steps selected in the menu. If a room sensor is installed and activated the desired room temperature (°C) is set.

If there is more than one climate system the setting can be made separately for each system.

**Menu 1.9.3 - min. flow line temp.**

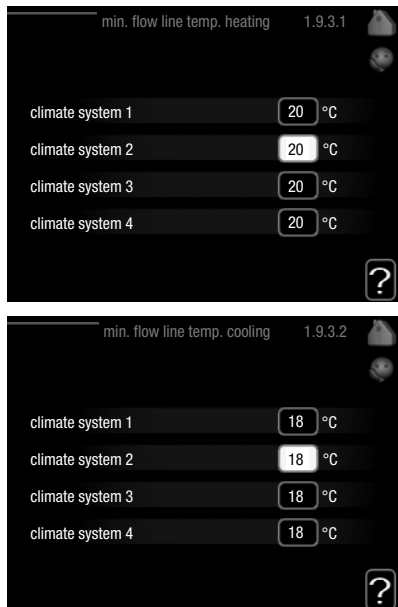

\*If there is one climate system, display shows "climate system 1" only.

**heating**

Setting range: 5 – 70 °C  
Default value: 20 °C

**cooling (heat pump with cooling function required)**

Depending on which cooling function (2-pipe /4-pipe system) is used, the lower limit of the setting range can vary from 7 to 18 °C.

Setting range: 7 – 30 °C  
Factory setting: 18 °C

In menu 1.9.3 you select heating or cooling, in the next menu (min. supply temp.heating/cooling) set the minimum temperature on the supply temperature to the climate system. This means that RC-HY20/40-W never calculates a temperature lower than that set here.

If there is more than one climate system the setting can be made separately for each system.

**TIP**

*The value can be increased if you have, for example, a cellar that you always want to heat, even in summer.  
You may also need to increase the value in "stop heating" menu 4.9.2 "auto mode setting".*

**Menu 1.9.4 - room sensor settings**

**factor system**

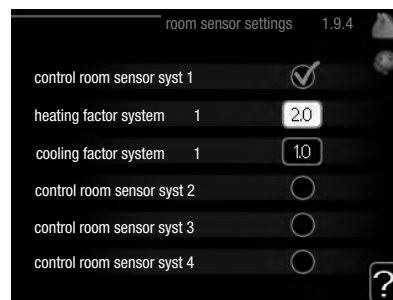

\*If there is one climate system, display shows "control room sensor system 1" only.

**heating**

Setting range: 0.0 – 6.0  
Factory setting heating: 2.0

**cooling (accessory required)**

Setting range: 0.0 – 6.0  
Factory setting cooling: 1.0

Room sensors to control the room temperature can be activated here.

**CAUTION**

*A slow heat-releasing heating system, such as for example, underfloor heating, may not be suitable for control using the heat pump's room sensor.*

Here you can set a factor (a numerical value) that determines how much an over or sub normal temperature (the difference between the desired and actual room temperature) in the room is to affect the supply temperature to the climate system. A higher value gives a greater and faster change of the heating curve's set offset.

**NOTE**

*Too high a set value for "factor system" can (depending on your climate system) produce an unstable room temperature.*

If several climate systems are installed the above settings can be made for the relevant systems.

**Menu 1.9.5 - cooling settings**

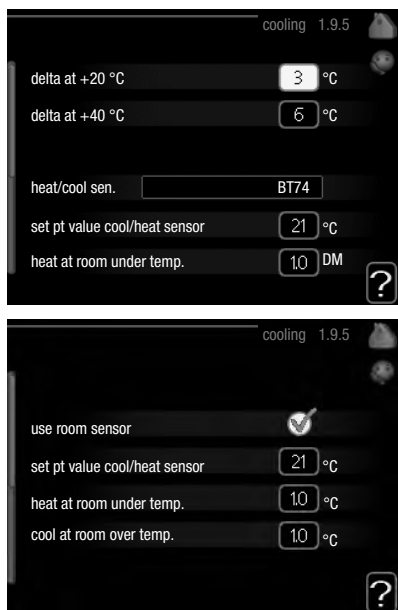

**delta at +20 °C**

Setting range: 3 – 10 °C  
Factory setting: 3

**delta at +40 °C**

Setting range: 3 – 20 °C  
Factory setting: 6

**heat/cool sen.**

Setting range: BT74 (BT50, RMU-BT50)  
Factory setting: BT74

**set pt value cool/heat sensor**

Setting range: 5 – 40 °C  
Factory setting: 21

**heat at room under temp.**

Setting range: 0.5 – 10.0 °C  
Default value: 1.0

**cool at room over temp.**

Setting range: 0.5 – 10.0 °C  
Default value: 3.0

**start active cooling**

Setting range: 10 – 300 DM  
Factory setting: 30 DM

**step difference compressors (RC-HY40-W only)**

Setting range: 10 – 150  
Default value: 30

**degree minutes cooling (RC-HY40-W only)**

Setting range: -3000 – 3000 cooling degree minutes  
Factory setting: -1

**time betw. switch heat/cool**

Setting range: 0 – 48 h  
Factory setting: 2

You can use RC-HY20/40-W to cool the house during hot periods of the year.

**CAUTION**

*Certain setting options only appear if their function is installed and activated in RC-HY20/40-W.*

**delta at +20 °C**

Set the desired temperature difference between supply and return lines to the climate system during cooling operation when the outdoor temperature is +20 °C. RC-HY20/40-W then attempts to get as close to the set temperature as possible.

**delta at +40 °C**

Set the desired temperature difference between supply and return lines to the climate system during cooling operation when the outdoor temperature is +40 °C. RC-HY20/40-W then attempts to get as close to the set temperature as possible.

**heat/cool sen.**

If a particular room will determine how the whole installation will work, a room sensor (BT74) is used. If room sensor (BT74) is connected to RC-HY20/40-W, room sensor (BT74) determines when it is time to switch between cooling and heating operation for the whole installation.

**CAUTION**

*When the heating/cooling sensors (BT74) have been connected and activated in menu 5.4, no other sensor can be selected in menu 1.9.5.*

**set pt value cool/heat sensor**

Here you can set at which indoor temperature RC-HY20/40-W is to shift between heating respectively cooling operation.

**heat at room under temp.**

Here you can set how far the room temperature can drop below the desired temperature before RC-HY20/40-W switches to heating operation.

**cool at room over temp.**

Here you can set how high the room temperature can increase above the desired temperature before RC-HY20/40-W switches to cooling operation.

**start active cooling**

Here you can set when active cooling is to start.

Degree minutes are a measurement of the current heating demand in the house and determine when the compressor, cooling operation respectively additional heat will start/stop.

**step difference compressors (RC-HY40-W only)**

**CAUTION**

*This setting option only appears if cooling is activated in menu 5.2.4.*

The degree minute difference for controlling when the next compressor is to start is set here.

**degree minutes cooling (RC-HY40-W only)**

This selection is only available when the connected accessory itself counts cooling degree minutes.

After a min. or max. value has been set, the system will automatically set the real value in relation to the number of compressors that are running cooling.

**time betw. switch heat/cool**

This selection is only available in cooling 2-pipe systems.

Here you can set how long RC-HY20/40-W is to wait before it returns to heating mode when the cooling demand has ceased or vice versa.

**Menu 1.9.7 - own curve**

**supply temperature**

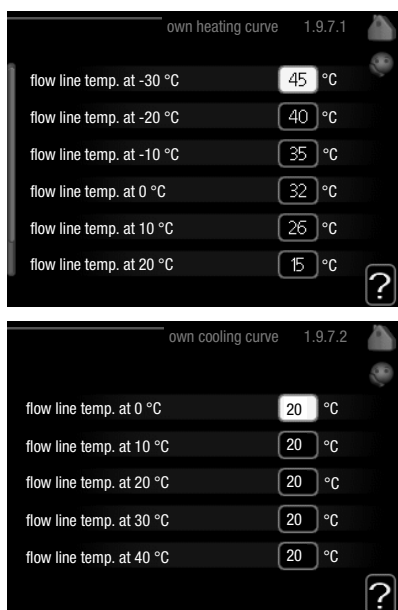

**heating**

Setting range: 5 – 70 °C

**cooling (accessory required)**

Depending on which accessory is used the setting range can vary.

Setting range: -5 – 40 °C

Create your own heating or cooling curve here, by setting the desired supply temperatures for different outdoor temperatures.

**CAUTION**

*Curve 0 in menu 1.9.1 must be selected for own curve to apply.*

**Menu 1.9.8 - point offset**

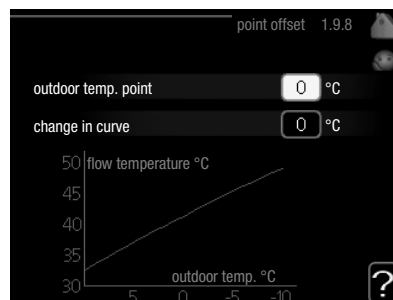

**outdoor temp. point**

Setting range: -40 – 30 °C

Default value: 0 °C

**change in curve**

Setting range: -10 – 10 °C

Default value: 0 °C

Select a change in the heating curve at a certain outdoor temperature here. One step is usually enough to change the room temperature by one degree, but in some cases several steps may be required.

The heat curve is affected at ± 5 °C from set outdoor temp. point.

It is important that the correct heating curve is selected so that the room temperature is experienced as even.

**TIP**

*If it is cold in the house, at, for example -2 °C, "outdoor temp. point" is set to "-2" and "change in curve" is increased until the desired room temperature is maintained.*

**CAUTION**

*Wait 24 hours before making a new setting, so that the room temperature has time to stabilise.*

## Set the hot water capacity

### Overview

#### Sub-menus

This menu only appears if a water heater is docked to the heat pump.

For the menu "HOT WATER" there are several sub-menus. Status information for the relevant menu can be found on the display to the following menus.

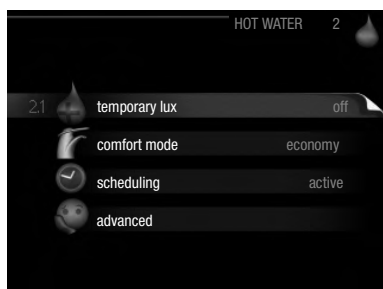

**"temporary lux"** Activation of temporary increase in the hot water temperature. Status information displays "off" or what length of time of the temporary temperature increase remains.

**"comfort mode"** Setting hot water comfort. The status information displays what mode is selected, "economy", "normal" or "luxury".

**"scheduling"** Scheduling hot water comfort. The status information "set" appears if you have set scheduling but it is not currently active, "holiday setting" appears if holiday setting is active at the same time as scheduling (when the holiday function is prioritised), "active" appears if any part of scheduling is active, otherwise "off" appears.

**"advanced"** Setting periodic increase in the hot water temperature.

#### Menu 2.1 - temporary lux

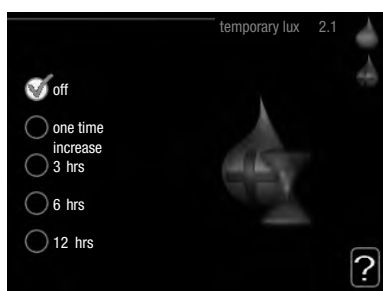

Setting range: 3, 6 and 12 hours  
and mode "off" and "one time increase"  
Default value: "off"

When hot water requirement has temporarily increased this menu can be used to select an increase in the hot water temperature to lux mode for a selectable time.

### CAUTION

*If comfort mode "luxury" is selected in menu 2.2 no further increase can be carried out.*

The function is activated immediately when a time period is selected and confirmed using the OK button. The remaining time for the selected setting is shown to the right.

When the time has run out RC-HY20/40-W returns to the mode set in menu 2.2. Select "off" to switch off temporary lux .

#### Menu 2.2- comfort mode



Setting range: economy, normal, luxury  
Default value: normal

The difference between the selectable modes is the temperature of the hot tap water. Higher temperature means that the hot water lasts longer.

**smart control:** In this menu you activate the Smart Control function. The function learns the previous week's hot water consumption and adapts the temperature in the water heater for the coming week to ensure minimal energy consumption. If the hot water demand is greater, there is a certain additional amount of hot water available. When the Smart Control function is activated, the water heater delivers the reported performance according to the energy decal.

**economy:** This mode gives less hot water than the others, but is more economical. This mode can be used in smaller households with a small hot water requirement.

**normal:** Normal mode gives a larger amount of hot water than the economy mode and is suitable for most households.

**luxury:** Lux mode gives the greatest possible amount of hot water. In this mode, the immersion heater, as well as the compressor, is used to heat hot water, which may increase operating costs.

**Menu 2.3 - scheduling**

Two different periods of hot water comfort per day can be scheduled here.

Scheduling is activated/deactivated by ticking/unticking "activated". Set times are not affected at deactivation.

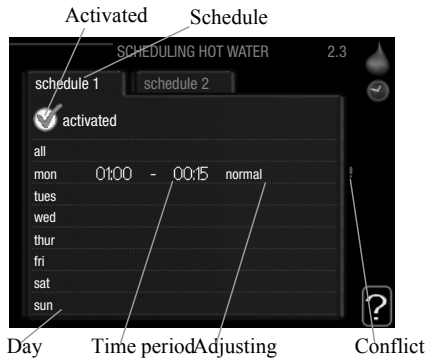

**Schedule:** The schedule to be changed is selected here.

**Activated:** Scheduling for the selected period is activated here. Set times are not affected at deactivation.

**Day:** Select which day or days of the week the schedule is to apply to here.

To remove the scheduling for a particular day, the time for that day must be reset by setting the start time to the same as the stop time. If the line "all" is used, all days in the period are set for these times.

**Time period:** The start and stop time for the selected day for scheduling are selected here.

**Adjusting:** Set the hot water comfort that is to apply during scheduling here.

**Conflict:** If two settings conflict with each other a red exclamation mark is displayed.

**TIP**  
*If you wish to set similar scheduling for every day of the week start by filling in "all" and then changing the desired days.*

**TIP**  
*Set the stop time earlier than the start time so that the period extends beyond midnight. Scheduling then stops at the set stop time the day after.  
Scheduling always starts on the date that the start time is set for.*

**Menu 2.9 - advanced**

Menu "advanced" has orange text and is intended for the advanced user. This menu has several sub-menus.

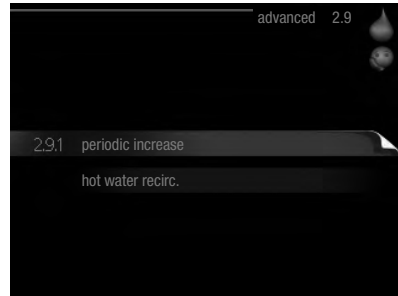

**Menu 2.9.1 - periodic increase**



**period**

Setting range: 1 – 90 days  
Default value: 14 days

**start time**

Setting range: 00:00 – 23:00  
Default value: 00:00

To prevent bacterial growth in the water heater, the heat pump and any additional heater can increase the hot water temperature for a short time at regular intervals.

The length of time between increases can be selected here. The time can be set between 1 and 90 days. Factory setting is 14 days. Tick/untick "activated" to start/switch off the function.

**Menu 2.9.2 - hot water recirc. (accessory required)*****operating time***

Setting range: 1 – 60 min

Default value: 60 min

***downtime***

Setting range: 0 – 60 min

Default value: 0 min

Set the hot water circulation for up to three periods per day here. During the set periods the hot water circulation pump will run according to the settings above.

"operating time" decide how long the hot water circulation pump must run per operating instance.

"downtime" decide how long the hot water circulation pump must be stationary during operating instances.

Hot water circulation is activated in menu 5.4 "soft inputs and outputs".

### Get information

#### Overview

#### Sub-menus

For the menu "INFO" there are several sub-menus. No settings can be made in these menus, they just display information. Status information for the relevant menu can be found on the display to the following menus.



"**service info**" shows temperature levels and settings in the installation.

"**compressor info**" shows operating times, number of starts etc for the compressor in the heat pump.

"**add. heat info**" displays information about the additional heat's operating times etc.

"**alarm log**" shows the latest alarms.

"**indoor temp. log**" the average temperature indoors week by week during the past year.

### Menu 3.1 - service info

Information about the actual operating status of the installation (e.g. current temperatures etc.) can be obtained here. But no changes can be made.

The information is on several pages. Turn the control knob to scroll between the pages.



#### Symbols in this menu:

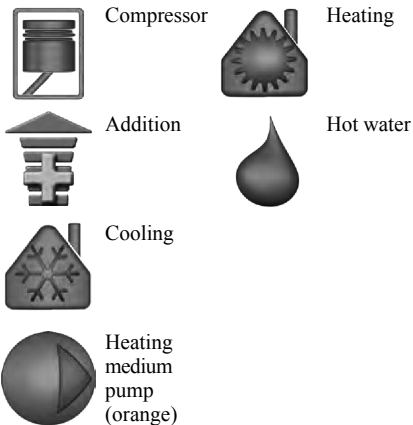

### Menu 3.2 - compressor info

Information about the compressor's operating status and statistics can be obtained here. But no changes can be made.

If there is more than one climate system the information is on several pages. Turn the control knob to scroll between the pages.

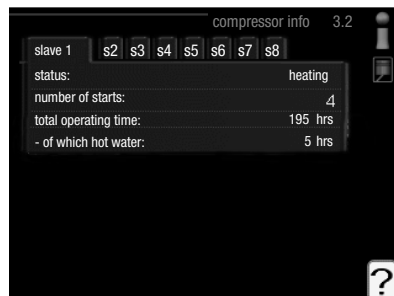



**Menu 3.3 - add. heat info**

Information about the additional heat's settings, operating status and statistics can be obtained here. But no changes can be made.

If there is more than one climate system the information is on several pages. Turn the control knob to scroll between the pages.

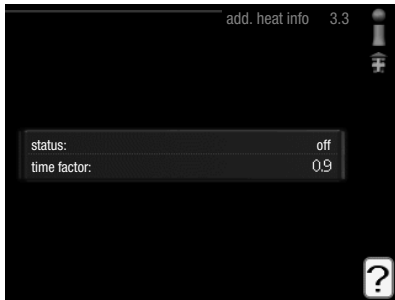

**Menu 3.4 - alarm log**

To facilitate fault-finding the installation's operating status at alarm alerts is stored here. You can see information for the 10 most recent alarms.

To view the run status in the event of an alarm, mark the alarm and press the OK button.

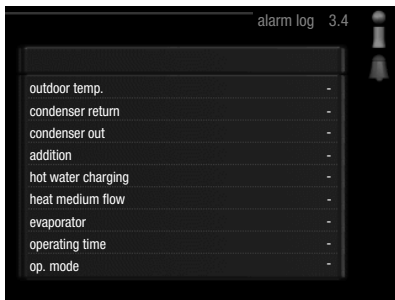
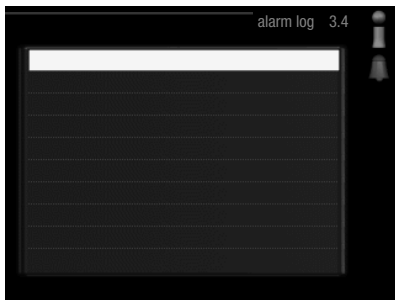

Information about an alarm.

**Menu 3.5 - indoor temp. log**

Here you can see the average temperature indoors week by week during the past year. The dotted line indicates the annual average temperature.

The average outdoor temperature is only shown if a room temperature sensor/room unit is installed.

**To read off an average temperature**

- 1 Turn the control knob so that the ring on the shaft with the week number is marked.
- 2 Press the OK button.
3. Follow the grey line up to the graph and out to the left to read off the average indoor temperature at the selected week.
4. You can now select to take read outs for different weeks by turning the control knob to the right or left and read off the average temperature.
5. Press the OK or Back button to exit read off mode.

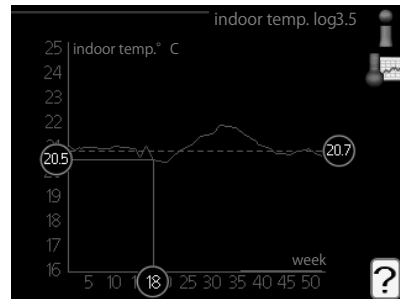

## Adjust the heat pump

### Overview

#### Sub-menus

For the menu "MY SYSTEM" there are several sub-menus. Status information for the relevant menu can be found on the display to the right of the menus.

**"plus functions"** Settings applying to any installed extra functions in the heating system.

**"op. mode"** Activation of manual or automatic operating mode. The status information shows the selected operating mode.

**"my icons"** Settings regarding which icons in the control module's user interface that are to appear on the hatch when the door is closed.

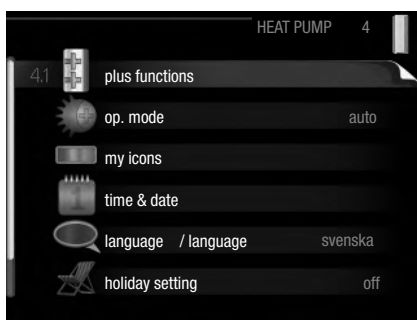

**"time & date"** Setting current time and date.

**"language"** Select the language for the display here. The status information shows the selected language.

**"holiday setting"** Vacation scheduling heating, hot water and ventilation. Status information "set" is displayed if you set a vacation schedule but it is not active at the moment, "active" is displayed if any part of the vacation schedule is active, otherwise it displays "off".

**"advanced"** Settings of control module work mode.

### Menu 4.1 - plus functions

Settings for any additional functions installed in RC-HY20/40-W can be made in the sub-menus.

#### Menu 4.1.1/4.1.2 - Pool 1/Pool 2

Here you can activate pool heating and set start and stop temperatures.

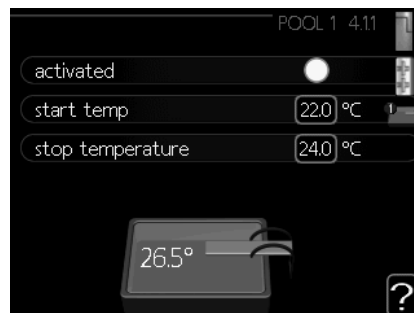

#### start temp

Setting range: 5 – 80 °C

Default value: 22 °C

#### stop temperature

Setting range: 5 – 80 °C

Default value: 24 °C

#### maximum number of compr. (Cascade only)

Setting range: 1 – 8

Default value: 8

Select whether the pool control is to be activated, within what temperatures (start and stop temperature) pool heating must occur and how many compressors may work again the pool at the same time.

Maximum number of compressors gives the possibility of restricting the number of compressors that are permitted to work with pool heating. The setting can be adjusted if requirements other than pool heating must be prioritised for example.

When the pool temperature drops below the set temperature and there is no hot water or heating requirement, RC-HY40-W starts pool heating.

Untick "activated" to switch off the pool heating.

### CAUTION

*The start temperature cannot be set to a value that is higher than the stop temperature.*

### Menu 4.1.3 - internet

Here you make settings for connecting RC-HY20/40-W to the internet.

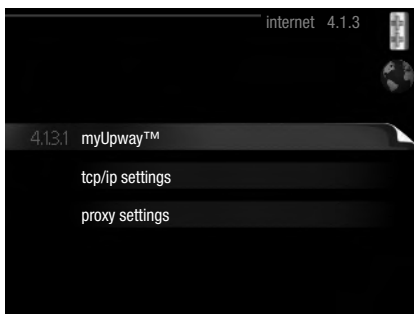

#### NOTE

For these functions to work the network cable must be connected.

### Menu 4.1.3.1 - myUpway™

Here you can manage the installation's connection to myUpway™ (www.myUpway.com) and see the number of users connected to the installation via the internet.

A connected user has a user account in myUpway™, which has been given permission to control and/or monitor your installation.

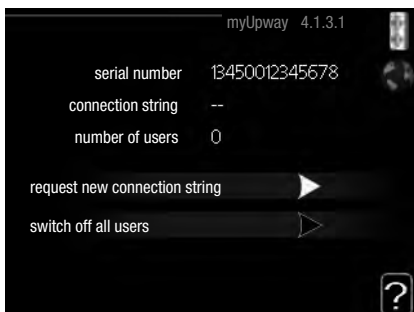

#### Request new connection string

To connect a user account on myUpway™ to your installation, you must request a unique connection code.

1. Mark "request new connection string" and press the OK button.
2. The installation now communicates with myUpway™ to create a connection code.
3. When a connection string has been received, it is shown in this menu at "connection string" and is valid for 60 minutes.

### Disconnect all users

1. Mark "switch off all users" and press the OK button.
2. The installation now communicates with myUpway™ to release your installation from all users connected via the internet.

#### NOTE

After disconnecting all users, none of them can monitor or control your installation via myUpway™ without requesting a new connection code

### Menu 4.1.3.8 - tcp/ip settings

You can set TCP/IP settings for your installation here.

#### Automatic setting (DHCP)

1. Tick "automatic". The installation now receives the TCP/IP settings using DHCP.
2. Mark "confirm" and press the OK button.



#### Manual setting

1. Untick "automatic", you now have access to several setting options.
2. Mark "ip-address" and press the OK button.
3. Enter the correct details via the virtual keypad.
4. Mark "OK" and press the OK button.
5. Repeat 1 - 3 for "net mask", "gateway" and "dns".
6. Mark "confirm" and press the OK button.

#### CAUTION

The installation cannot connect to the internet without the correct TCP/IP settings. If unsure about applicable settings use the automatic mode or contact your network administrator (or similar) for further information.

#### TIP

All settings made since opening the menu can be reset by marking "reset" and pressing the OK button.

### Menu 4.1.3.9 - proxy settings

You can set proxy settings for your installation here.

Proxy settings are used to give connection information to a intermediate server (proxy server) between the installation and internet. These settings are primarily used when the installation connects to the internet via a company network. The installation supports proxy authentication of the HTTP Basic and HTTP Digest type.

If unsure about applicable settings, contact your network administrator (or similar) for further information.

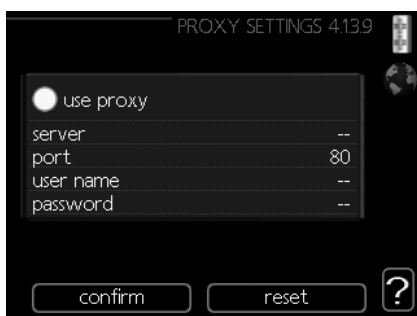

#### Setting

1. Tick "use proxy" if you do not want to use a proxy.
2. Mark "server" and press the OK button.
3. Enter the correct details via the virtual keypad.
4. Mark "OK" and press the OK button.
5. Repeat 1 - 3 for "port", "user name" and "password".
6. Mark "confirm" and press the OK button.

#### TIP

All settings made since opening the menu can be reset by marking "reset" and pressing the OK button.

### Menu 4.1.5 - SG Ready

This function can only be used in SG Ready 4.1.5 mains networks that support the "SG Ready"-standard .

Make settings for the function "SG Ready" here.

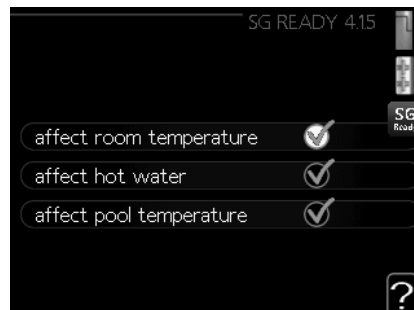

#### affect room temperature

Here you set whether room temperature should be affected when activating "SG Ready".

With low price mode on "SG Ready" the parallel offset for the indoor temperature is increased by "+1". If a room sensor is installed and activated, the desired room temperature is instead increased by 1 °C.

With over capacity mode on "SG Ready" the parallel offset for the indoor temperature is increased by "+2". If a room sensor is installed and activated, the desired room temperature is instead increased by 2 °C.

#### affect hot water

Here you set whether the temperature of the hot water should be affected when activating "SG Ready".

With low price mode on "SG Ready" the stop temperature of the hot water is set as high as possible at only compressor operation (immersion heater not permitted).

With over capacity mode of "SG Ready" the hot water is set to "luxury" (immersion heater permitted).

#### affect cooling (accessory required)

Here you set whether room temperature during cooling operation should be affected when activating "SG Ready".

With low price mode of "SG Ready" and cooling operation the indoor temperature is not affected.

With over capacity mode on "SG Ready" and cooling operation, the parallel offset for the indoor temperature is reduced by "-1". If a room sensor is installed and activated, the desired room temperature is instead reduced by 1 °C.

#### NOTE

The function must be connected and activated in your RC-HY20/40-W.

**Menu 4.1.6 - Smart price adaption™**

**area**

In this menu you state where the heat pump is located and how great a role the electricity price should play. The greater the value, the greater the effect the electricity price has and the possible savings are larger, but at the same time there is an increased risk of affecting comfort. Smart price adaption is available on selected markets, at present Austria, Denmark, Estonia, Finland, Norway and Sweden.

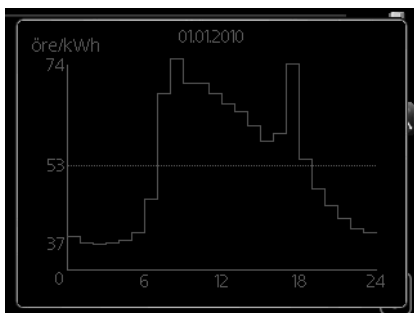
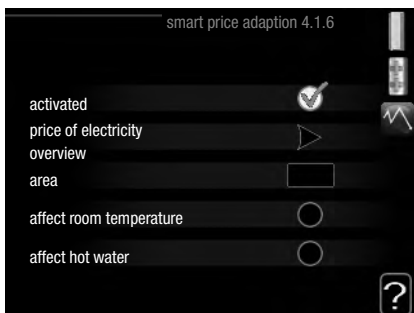

**price of electricity overview**

Here you can obtain information on how the electricity price varies over up to three days.

**affect room temperature**

Setting range: 1 – 10  
Factory setting: 5

**affect hot water**

Setting range: 1 – 4  
Factory setting: 2

**affect cooling**

Setting range: 1 – 10  
Factory setting: 3

Smart price adaption™ moves the heat pump's consumption over 24 hours to periods with the cheapest electricity tariff, which gives savings for hourly rate based electricity contracts. The function is based on hourly rates for the next 24 hours being retrieved via myUpway™ and therefore an internet

connection and an account for myUpway™ are required. Deselect "activated" to switch off Smart price adaption™.

**Menu 4.1.8 - smart energy source™ (RC-HY40-W only)**

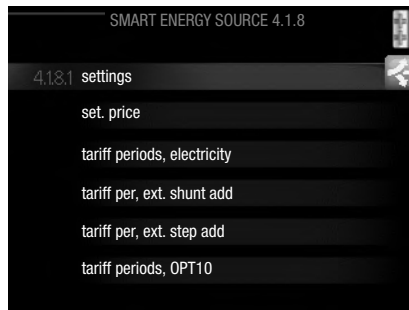

- settings**
- set. price**
- CO2 impact\***
- tariff per, ext. shunt add**
- tariff per, ext. step add**

The function prioritises how / to what extent each docked energy source will be used. Here you can choose if the system is to use the energy source that is cheapest at the time. You can also choose if the system is to use the energy source that is most carbon neutral at the time.

\*Select control method "CO<sub>2</sub>" under settings to open this menu.

**Menu 4.1.8.1 - settings**

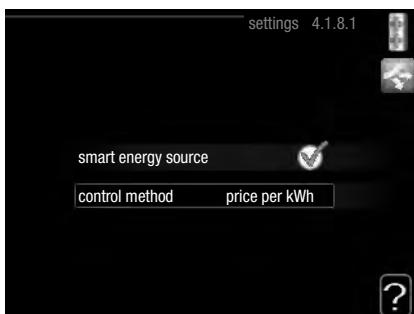

**smart energy source™**

Setting range: Off/On

Factory setting: Off

**control method**

Setting range: Price /CO<sub>2</sub>

Factory setting: Price

**Menu 4.1.8.2 - set. price**

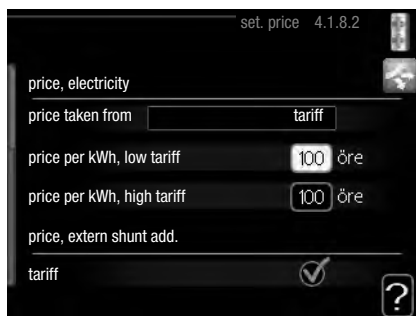

**price, electricity**

Setting range: spot, tariff, fixed price

Factory setting: fixed price

Setting range fixed price: 0 – 100,000\*

**price, extern shunt add.**

Setting range: tariff, fixed price

Factory setting: fixed price

Setting range fixed price: 0 – 100,000\*

**price, extern step add.**

Setting range: tariff, fixed price

Factory setting: fixed price

Setting range fixed price: 0 – 100,000\*

Here you can choose if the system is to exercise control based on the spot price, tariff control or a set price. The setting is made for each individual energy source. Spot price can only be used if you have an hourly tariff agreement with your electricity supplier.

\*The currency varies depending on the country selected.

**Menu 4.1.8.3 - CO2 impact**

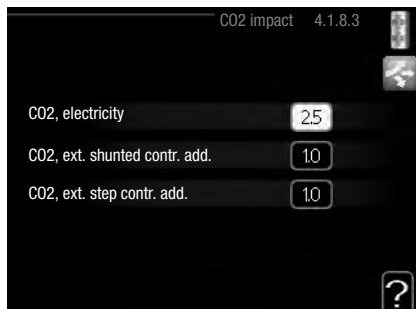

**CO2, electricity**

Setting range: 0 – 5  
Default value: 2.5

**CO2, ext. shunted contr. add.**

Setting range: 0 – 5  
Default value: 1

**CO2, ext. step contr. add.**

Setting range: 0 – 5  
Default value: 1

Here you set the size of the carbon footprint for each energy source.

The carbon footprint is different for different energy sources. For example, the energy from solar cells and wind turbines can be considered carbon dioxide neutral and, therefore, has a low CO2 impact. Energy from fossil fuels can be considered to have a higher carbon footprint and, therefore, has a higher CO2 impact.

**Menu 4.1.8.4 - tariff periods, electricity**

Here you can use tariff control for the electric additional heat. Set the lower tariff periods. It is possible to set two different date periods per year. Within these periods, it is possible to set up to four different periods on weekdays (Monday to Friday) or four different periods on weekends (Saturdays and Sundays).

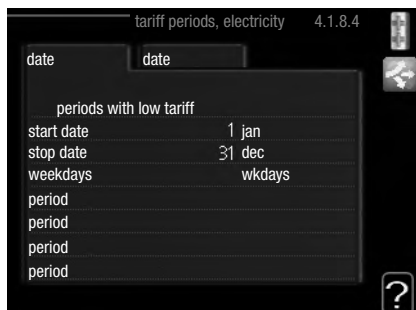

**Menu 4.1.8.6 - tariff per, ext. shunt add**

Here you can use tariff control for the external shunted additional heat.

Set the lower tariff periods. It is possible to set two different date periods per year. Within these periods, it is possible to set up to four different periods on weekdays (Monday to Friday) or four different periods on weekends (Saturdays and Sundays).

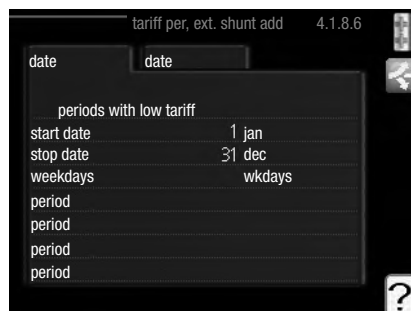

**Menu 4.1.8.7 - tariff per, ext. step add**

Here you can use tariff control for the external step controlled additional heat.

Set the lower tariff periods. It is possible to set two different date periods per year. Within these periods, it is possible to set up to four different periods on weekdays (Monday to Friday) or four different periods on weekends (Saturdays and Sundays).



**Menu 4.1.10 - Solar electricity**

Here you set whether you want EME20M to affect the room temperature and/or the hot water and/or pool.

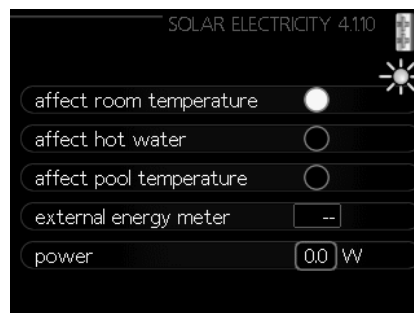

**affect room temperature**

Setting range: on/off  
Default value: off

**affect hot water**

Setting range: on/off  
Default value: off

**affect pool temperature**

Setting range: on/off  
Default value: off

**Menu 4.2 - op. mode**

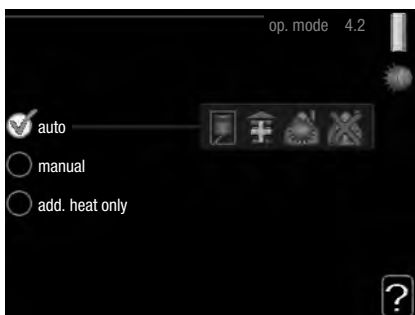

**op. mode**

Setting range: auto, manual, add. heat only  
Default value: auto

**functions**

Setting range: compressor, addition, heating, cooling

The control module operating mode is usually set to "auto". It is also possible to set the control module to "add. heat only", when only additional heat is used, or "manual" and then select what functions are to be permitted.

Change the operating mode by marking the desired mode and pressing the OK button. When an operating mode is selected it shows what in the control module is permitted (crossed out = not permitted) and selectable alternatives to the right. To select selectable functions that are permitted or not, mark the function using the control knob and press the OK button.

**Operating mode auto**

In this operating mode the control module automatically selects what functions are permitted.

**Operating mode manual**

In this operating mode you can select what functions are permitted. You cannot deselect "compressor" in manual mode.

**Operating mode add. heat only**

In this operating mode the compressor is not active, only additional heat is used.

**CAUTION**

*If you choose mode "add. heat only" the compressor is deselected and there is a higher operating cost.*

**CAUTION**

*You cannot change from only additional heat if you do not have a heat pump connected.*

**Functions**

"**compressor**" is that which produces heating and hot water for the accommodation. If "compressor" is deselected, a symbol is displayed in the main menu on the symbol for the control module. You cannot deselect "compressor" in manual mode.

"**addition**" is what helps the compressor to heat the accommodation and/or the hot water when it cannot manage the whole requirement alone.

"**heating**" means that you get heat in the accommodation. You can deselect the function when you do not wish to have heating running.

"**cooling**" means that you get cooling in the accommodation in hot weather. This alternative requires an accessory for cooling or that the heat pump has a built in function for cooling and is activated in the menu. You can deselect the function when you do not wish to have the cooling running.

**Menu 4.4 - time & date**

Set time and date, display mode and time zone here.



**TIP**

*Time and date are set automatically if the heat pump is connected to myUpway™. To obtain the correct time, the time zone must be set.*

**Menu 4.6 - language**

Choose the language that you want the information to be displayed in here.





### Menu 4.7 - holiday setting

To reduce energy consumption during a holiday you can schedule a reduction in heating and hot water temperature. Cooling can also be scheduled if the functions are connected.

If a room sensor is installed and activated, the desired room temperature (°C) is set during the time period. This setting applies to all climate systems with room sensors.



If a room sensor is not activated, the desired offset of the heating curve is set. One step is usually enough to change the room temperature by one degree, but in some cases several steps may be required. This setting applies to all climate systems without room sensors.

Vacation scheduling starts at 00:00 on the start date and stops at 23:59 on the stop date.

#### TIP

Complete holiday setting about a day before your return so that room temperature and hot water have time to regain usual levels.

#### TIP

Set the vacation setting in advance and activate just before departure in order to maintain the comfort.

#### CAUTION

If you choose to switch off hot water production during the vacation "periodic increase" (preventing bacterial growth) are blocked during this time. "periodic increase" started in conjunction with the vacation setting being completed.

### Menu 4.9 - advanced

Menu "advanced" has orange text and is intended for the advanced user. This menu has several sub-menus.



### Menu 4.9.1 - op. prioritisation

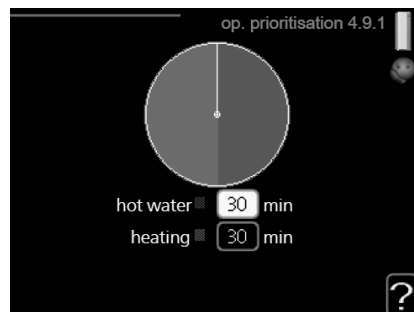

#### op. prioritisation

Setting range: 0 – 180 min  
Default value: 30 min

Choose here how long the installation should work with each requirement if there are several requirements at the same time. If there is only one requirement the installation only works with that requirement.

The indicator marks where in the cycle the installation is.

If 0 minutes is selected it means that requirement is not prioritised, but will only be activated when there is no other requirement.

### Menu 4.9.2 - auto mode setting

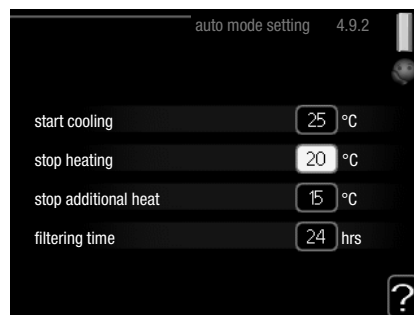

#### start cooling (accessory auto mode setting required)

Setting range: 15 – 40 °C  
Factory setting: 25

#### stop heating

Setting range: -20 – 40 °C  
Default values: 17

#### stop additional heat

Setting range: -25 – 40 °C  
Factory setting: 5

#### filtering time

Setting range: 0 – 48 h  
Default value: 24 h

When the operating mode is set to "auto", the control module selects when start and stop of additional heat and heat production is permitted, depending on the average outdoor

temperature. If the heat pump has the integrated cooling function and it is activated in the menu you can also select the start temperature for cooling.

Select the average outdoor temperatures in this menu.

You can also set the time over which (filtering time) the average temperature is calculated. If you select 0, the present outdoor temperature is used.

**CAUTION**

*It cannot be set "stop additional heat" higher than "stop heating".*

**CAUTION**

*In systems where heating and cooling share the same pipes "stop heating" cannot be set higher than "start cooling" if there is not a cooling/heating sensor.*

**Menu 4.9.3 - degree minute setting**

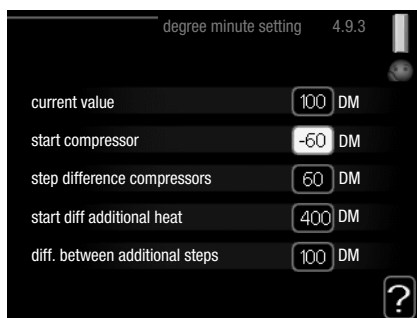

**current value**

Setting range: -3000 – 3000

**start compressor**

Setting range: -1000 – -30  
Default value: -60

**step difference compressors (RC-HY40-W only)**

Setting range: 10 – 2000  
Default value: 60

**start diff additional heat**

Setting range: 100 – 2000  
Factory setting: 400

**diff. between additional steps**

Setting range: 10 – 1000  
Factory setting: 30

Degree minutes are a measurement of the current heating requirement in the house and determine when the compressor respectively additional heat will start/stop.

**CAUTION**

*Higher value on "start compressor" gives more compressor starts, which increase wear on the compressor. Too low value can give uneven indoor temperatures.*

**Menu 4.9.4 - factory setting user**

All settings that are available to the user (including advanced menus) can be reset to default values here.



**CAUTION**

*After factory setting, personal settings such as heating curves must be reset.*

**Menu 4.9.5 - schedule blocking**

The additional heat can be scheduled to be blocked for up to two different time periods here.

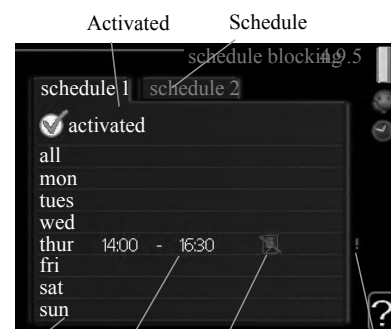

Day Time period Blocking Conflict

When scheduling is active the relevant blocking symbol is shown in the main menu on the symbol for the control module.

**Schedule:** The period to be changed is selected here.

**Activated:** Scheduling for the selected period is activated here. Set times are not affected at deactivation.

**Day:** Select which day or days of the week the schedule is to apply to here. To remove the scheduling for a particular day, the time for that day must be reset by setting the start time to the same as the stop time. If the line "all" is used, all days in the period are set for these times.

**Time period:** The start and stop time for the selected day for scheduling are selected here.

**Blocking:** The desired blocking is selected here.

**Conflict:** If two settings conflict with each other a red exclamation mark is displayed.



Blocking the compressor in the outdoor unit.



Blocking additional heat.

**TIP**

If you wish to set similar scheduling for every day of the week start by filling in "all" and then changing the desired days.

**TIP**

Set the stop time earlier than the start time so that the period extends beyond midnight. Scheduling then stops at the set stop time the day after. Scheduling always starts on the date that the start time is set for.

**CAUTION**

Long term blocking can cause reduced comfort and operating economy.

**TIP**

If you wish to set similar scheduling for every day of the week start by filling in "all" and then changing the desired days.

**TIP**

Set the stop time earlier than the start time so that the period extends beyond midnight. Scheduling then stops at the set stop time the day after. Scheduling always starts on the date that the start time is set for.

**CAUTION**

Long term scheduling of "silent mode" can cause reduced comfort and operating economy.

**Menu 4.9.6 - schedule silent mode**

The compressor can be scheduled to be set to "silent mode" (the heat pump must support this) for up to two different time periods here.

When scheduling is active the "silent mode" symbol is shown in the main menu on the symbol for the control module.

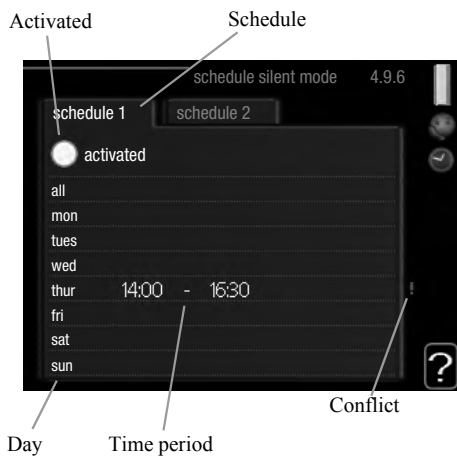

- Schedule:** The period to be changed is selected here.
- Activated:** Scheduling for the selected period is activated here. Set times are not affected at deactivation.
- Day:** Select which day or days of the week the schedule is to apply to here. To remove the scheduling for a particular day, the time for that day must be reset by setting the start time to the same as the stop time. If the line "all" is used, all days in the period are set for these times.
- Time period:** The start and stop time for the selected day for scheduling are selected here.
- Conflict:** If two settings conflict with each other a red exclamation mark is displayed.

## Sub-menus

Menu SERVICE has orange text and is intended for the advanced user. This menu has several sub-menus.

Status information for the relevant menu can be found on the display to the right of the menus.

**operating settings:** Operating settings for the control module.

**system settings:** System settings for the control module, activating accessories etc.

**soft in/outputs:** Setting software controlled in and outputs on the input card (AA3) and terminal block (X2).

**factory setting service:** Total reset of all settings (including settings available to the user ) to default values.

**forced control:** Forced control of the different components in the indoor module.

**start guide:** Manual start of the start guide which is run the first time when the control module is started.

**quick start:** Quick starting the compressor.

### NOTE

*Incorrect settings in the service menus can damage the installation.*

## Menu 5.1 - operating settings

Operating settings can be made for the control module in the sub-menus.

### Menu 5.1.1 - hot water settings

#### economy

Setting range start temp. economy: 5 – 55 °C

Factory setting start temp. economy: 42 °C

Setting range stop temp. economy: 5 – 60 °C

Factory setting stop temp. economy: 48 °C

#### normal

Setting range start temp. normal: 5 – 60 °C

Factory setting start temp. normal: 46 °C

Setting range stop temp. normal: 5 – 65 °C

Factory setting stop temp. normal: 50 °C

#### luxury

Setting range start temp. lux: 5 – 70 °C

Factory setting start temp. lux: 49 °C

Setting range stop temp. lux: 5 – 70 °C

Factory setting stop temp. lux: 53 °C

#### stop temp. per. increase

Setting range: 55 – 70 °C

Factory setting: 55 °C

#### charge method

Setting range: target temp, delta temp.

Default value: delta temp.

Here you set the start and stop temperature of the hot water for the different comfort options in menu 2.2 as well as the stop temperature for periodic increase in menu 2.9.1.

The charge method for hot water mode is selected here. "delta temp" is recommended for heaters with charge coil, "target temp" for heaters with domestic coil.

### Menu 5.1.2 - max flow line temperature

#### climate system

Setting range: 5 – 70 °C

Default value: 60 °C

Set the maximum supply temperature for the climate system here. If the installation has more than one climate system, individual maximum supply temperatures can be set for each system. Climate systems 2 – 8 cannot be set to a higher max supply temperature than climate system 1.

### CAUTION

*Underfloor heating systems are normally max flow line temperature set between 35 and 45°C.*

*Be careful not to cause low temperature burn if it is set at 35°C or higher.*

*Check the max floor temperature with your floor supplier.*

**Menu 5.1.3 - max diff flow line temp.****max diff compressor**

Setting range: 1 – 25 °C  
Default value: 10 °C

**max diff addition**

Setting range: 1 – 24 °C  
Default value: 7 °C

Here you set the maximum permitted difference between the calculated and actual supply temperature during compressor mode and add. heat mode. Max diff. additional heat can never exceed max diff. compressor

**max diff compressor**

When the current supply temperature **deviates** from the set value compared to that calculated, the heat pump is forced to stop irrespective of the degree minute value.

If the current supply temperature exceeds the calculated flow temperature plus the set value, the degree minute value is set to 0. The compressor in the heat pump stops when there is only a heating demand.

**max diff addition**

If "addition" is selected and activated in menu 4.2 and the present supply temp **exceeds** the calculated temperature plus the set value, the additional heat is forced to stop.

**Menu 5.1.4 - alarm actions**

Select how to control the heat pump in the event of an alarm. You can choose to stop producing hot water and/or reduce the room temperature.

**CAUTION**

*If no alarm action is selected, it can result in higher energy consumption in the event of an alarm.*

**Menu 5.1.12 - addition**

add type: step controlled

**max step**

Setting range (binary stepping deactivated): 0 – 3  
Setting range (binary stepping activated): 0 – 7  
Default value: 3

**fuse size**

Setting range: 1 – 200 A  
Factory setting: 16 A

You can set the maximum number of permitted additional heat steps, if there is internal additional heat in the tank (only accessible if the additional heat is positioned after QN10), whether binary stepping is to be used and the size of the fuse.

**<Add. Type: shunt controlled (RC-HY40 only)>****prioritised additional heat**

Setting range: on/off  
Factory setting: off

**minimum running time**

Setting range: 0 – 48 h  
Default value: 12 h

**min temp.**

Setting range: 5 – 90 °C  
Default value: 55 °C

**mixing valve amplifier**

Setting range: 0.1 – 10.0  
Default value: 1.0

**mixing valve step delay**

Setting range: 10 – 300 s  
Default values: 30 s

**fuse size**

Setting range: 1 – 200 A  
Factory setting: 16 A

**transformation ratio**

Setting range: 300 – 3000  
Factory setting: 300

Select this option if shunt controlled additional heat is connected.

Set when the addition is to start, the minimum run time and the minimum temperature for external addition with shunt here. External addition with shunt is for example a wood/oil/gas/pellet boiler.

You can set shunt valve amplification and shunt valve waiting time.

Selecting "prioritised additional heat" uses the heat from the external additional heat instead of the heat pump.

The shunt valve is regulated as long as heat is available, otherwise the shunt valve is closed.

**TIP**

*See the accessory installation instructions for function description.*

**Menu 5.1.14 - flow set. climate system****presettings**

Setting range: radiator, floor heat., rad. + floor heat.  
Default value: radiator  
Setting range DOT: -40.0 – 20.0 °C

The factory setting of DOT value depends on the country that has been given for the product's location. The example below refers to Sweden.

Factory setting DOT: -20.0 °C

**own setting**

Setting range dT at DOT: 0.0 – 25.0

Factory setting dT at DOT: 10.0  
 Setting range DOT: -40.0 – 20.0 °C  
 Factory setting DOT: -20.0 °C

Select the type of heating distribution system.

dT at DOT is the difference in degrees between flow and return temperatures at dimensioned outdoor temperature.

**Menu 5.1.22 - heat pump testing**

**NOTE**

*This menu is intended for testing heat pump according to different standards.  
 Use of this menu for other reasons may result in your installation not functioning as intended.*

This menu contains several sub-menus, one for each standard.

**Menu 5.1.23 - compressor curve**

Set whether the compressor in the heat pump should work to a particular curve under specific requirements or if it should work to predefined curves.

You can set a curve for each operation mode (heat, hot water, coolingetc.) by unticking "auto", turning the control knob until a temperature is marked and pressing OK. You can set at what temperature max- min frequencies will occur.

This menu consists of several windows (one for each operation mode). Use the navigation arrow in the top left corner to change between the windows.

**Menu 5.2 - system settings**

Make different system settings for your installation here, e.g. activate the connected heat pump and which accessories are installed.

**Menu 5.2.2 - installed heat pump**

If a heat pump is connected to the master installation, set it here.

For RC-HY40-W, you can set slave unit to be connected.

There are two ways of activating connected slaves. You can either mark the alternative in the list or use the automatic function "search installed slaves".

**search installed slaves**

Mark "search installed slaves" and press the OK button to automatically find connected slaves for the master heat pump.

**Menu 5.2.3 – docking (RC-HY40-W only)**

Enter how your system is docked regarding pipes, for example to hot water heating and heating the building.

This menu has a docking memory which means that the control system remembers how a particular reversing valve is docked and automatically enters the correct docking the next time you use the same reversing valve.

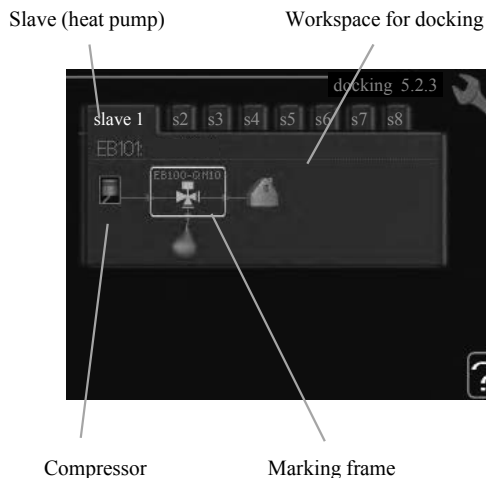







**Slave:** Here you select for which heat pump the docking setting is to be made.

**Compressor:** Select if the compressor in the heat pump is blocked (factory setting), or standard (docked for example to pool heating, hot water charging and heating the building).

**Marking frame:** Move around the marking frame using the control knob. Use the OK button to select what you want to change and to confirm setting in the options box that appears to the right.

**Workspace for docking:** The system docking is drawn here.

Symbol	Description
	Compressor (blocked)
	Compressor (standard)
	Reversing valves for hot water, cooling. The designations above the reversing valve indicate where it is electrically connected (EB101 = Slave 1, etc.).
	Hot water charging
	Heating (heating the building, includes any extra climate system)
	Cooling

### Menu 5.2.4 - accessories

Set which accessories are installed on the installation here.

If the water heater is connected, hot water charging must be activated here.

### Menu 5.3 - accessory settings

The operating settings for accessories that are installed and activated are made in the sub-menus for this.

#### Menu 5.3.2 - shunt controlled add. Heat

##### **prioritised additional heat**

Setting range: on/off

Factory setting: off

##### **start diff additional heat**

Setting range: 0 – 2000 GM

Default values: 400 GM

##### **minimum running time**

Setting range: 0 – 48 h

Default value: 12 h

##### **min temp.**

Setting range: 5 – 90 °C

Default value: 55 °C

##### **mixing valve amplifier**

Setting range: 0.1 – 10.0

Default value: 1.0

##### **mixing valve step delay**

Setting range: 10 – 300 s

Default values: 30 s

Set when the addition is to start, the minimum run time and the minimum temperature for external addition with shunt here. External addition with shunt is for example a wood/oil/gas/pellet boiler.

You can set shunt valve amplification and shunt valve waiting time.

Selecting "prioritised additional heat" uses the heat from the external additional heat instead of the heat pump.

The shunt valve is regulated as long as heat is available, otherwise the shunt valve is closed.

See the accessory installation instructions for function description.

#### Menu 5.3.3 - extra climate system

##### **use in heating mode**

Setting range: on/off

Factory setting: on

##### **use in cooling mode**

Setting range: on/off

Factory setting: off

##### **mixing valve amplifier**

Setting range: 0.1 – 10.0

Default value: 1.0

##### **mixing valve step delay**

Setting range: 10 – 300 s

Default values: 30 s

Here you select which climate system (2 – 8) you wish to set. In the next menu you can make settings for the climate system

that you have selected. If this function is activated, you can set "cooling flow temp. at +20°C" and "cooling flow temp. at +40°C" for each climate system where the function is activated.

## CAUTION

*This setting option only appears if "cooling permitted" is activated in menu 5.11.1.1.*

The shunt amplification and shunt waiting time for the different extra climate systems that are installed are also set here.

See the accessory installation instructions for function description.

### Menu 5.3.6 - step controlled add. heat

#### **start addition**

Setting range: 0 – 2000 GM

Default values: 400 GM

#### **diff. between additional steps**

Setting range: 0 – 1000 GM

Default values: 30 GM

#### **max step**

Setting range

(binary stepping deactivated): 0 – 3

Setting range

(binary stepping activated): 0 – 7

Default value: 3

#### **binary stepping**

Setting range: on/off

Factory setting: off

Make settings for step controlled addition here. Step controlled addition is for example an external electric boiler.

It is possible, for example, to select when the additional heat is to start, to set the maximum number of permitted steps and whether binary stepping is to be used.

When binary stepping is deactivated (off), the settings refer to linear stepping.

See the accessory installation instructions for function description.

### Menu 5.3.8 - hot water comfort

#### **activating imm heater**

Setting range: on/off

Factory setting: off

#### **activ. imm heat in heat mode**

Setting range: on/off

Factory setting: off

#### **activating the mixing valve**

Setting range: on/off

Factory setting: off

#### **outgoing hot water**

Setting range: 40 – 65 °C

Default value: 55 °C

#### **mixing valve amplifier**

Setting range: 0.1 – 10.0

Default value: 1.0

#### **mixing valve step delay**

Setting range: 10 – 300 s

Default values: 30 s

Make settings for the hot water comfort here.

See the accessory installation instructions for function description.

**activating imm heater:** The immersion heater is activated here if installed in the water heater.

**activ. imm heat in heat mode:** Activate here whether the immersion heater in the tank (required if the alternative above is activated) will be permitted to charge hot water, if the compressors in the heat pump prioritise heating.

**activating the mixing valve:** Activate here whether a mixer valve for limiting the temperature of hot water from the water heater is installed.

If this alternative has been activated, you can set the outgoing hot water temperature, shunt amplification and shunt waiting time for the mixer valve.

**outgoing hot water:** Set the temperature at which the mixing valve is to restrict hot water from the water heater.

See the accessory installation instructions for function description.

### Menu 5.3.20 - flow sensor

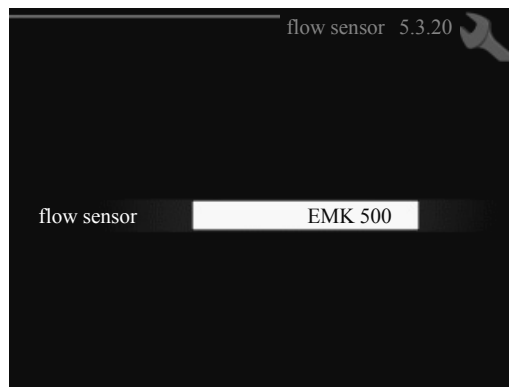

#### **flow sensor**

Setting option: EMK 500, EMK 310 / 300, EMK 150

Factory setting: EMK 500

Here you select which flow sensor is used for the energy measurement.



### Menu 5.4 – soft in/outputs

You can set the function of in/output for each terminal (AUX1-6 and output).

Position of the terminal depends on the type of controller.

RC-HY20-W: port 11-18 on X2 terminal (AUX1-6), X4 terminal on AA2 board (output)

RC-HY40-W: port 9-14 on terminal X6 and port 1-4 on X2 terminal on AA3 board (AUX1-6), X7 terminal on AA3 board (output)

### Menu 5.5 - factory setting service

All settings can be reset (including settings available to the user) to default values here.

#### NOTE

*When resetting, the start guide is displayed the next time the control module is restarted.*

### Menu 5.6 - forced control

You can force control the different components in the control module and any connected accessories here.

### Menu 5.7 - start guide

When the control module is started for the first time the start guide starts automatically. Start it manually here.

See page 76 for more information about the start guide.

### Menu 5.8 - quick start

It is possible to start the compressor from here.

#### CAUTION

*There must be a heating or hot water demand to start the compressor.*

#### CAUTION

*Do not quick start the compressor too many times over a short period of time as this may damage the compressor and its surrounding equipment.*

### Menu 5.9 - floor drying function

#### length of period 1 – 7

Setting range: 0 – 30 days

Factory setting, period 1 – 3, 5 – 7: 2 days

Factory setting, period 4: 3 days

#### temp. period 1 – 7

Setting range: 15 – 70 °C

Default value:

temp. period 1	20 °C
temp. period 2	30 °C
temp. period 3	40 °C
temp. period 4	45 °C
temp. period 5	40 °C
temp. period 6	30 °C
temp. period 7	20 °C

Set the function for under floor drying here.

You can set up to seven period times with different calculated flow temperatures. If less than seven periods

are to be used, set the remaining period times to 0 days.

Mark the active window to activate the underfloor drying function. A counter at the bottom shows the number of days the function has been active.

#### TIP

*If operating mode "add. heat only" is to be used, select it in menu 4.2.*

### Menu 5.10 - change log

Read off any previous changes to the control system here.

The date, time and ID No. (unique to certain settings) and the new set value is shown for every change.

#### NOTE

*The change log is saved at restart and remains unchanged after factory setting.*

**Menu 5.11 - heat pump settings**

Settings for installed heat pump can be made in the submenus.

**Menu 5.11.1 - EB101 - EB108**

Make settings specifically for the installed heat pump and charge pump here.

For RC-HY40-W, it is possible to connect up to 8 heat pumps.

**Menu 5.11.1.1 - heat pump**

Make settings for the installed heat pump here. To see what settings you can make, see installation manual for the heat pump.

**Cooling permitted**

Here you can set whether the cooling function is to be activated for the heat pump.

**Silent mode permitted**

Set whether silent mode is to be activated for the heat pump.

**Current limit**

Set whether the current limiting function is to be activated for the heat pump here.

**During active function you can limit the value of the maximum current.**

Setting range: 6 – 32 A

Factory setting: 32 A

**Stop temperature compressor**

Here you can limit the value for the set outdoor temperature down to the value the heat pump is to work.

Setting range: -20°C – -2°C

Factory setting: -20°C

**blockFreq 1**

Select a frequency range within the heat pump may work here.

**blockFreq 2**

Select a frequency range within the heat pump may work here.

**Menu 5.11.1.2 - charge pump (GP12)****op. mode**

Heating/cooling

Setting range: auto / intermittent

Default value: auto

Set the operating mode for the charge pump here.

**auto:** The charge pump runs according to the current operating mode for RC-HY20-W.

**intermittent:** The charge pump starts and stops 20 seconds before and after the compressor in the heat pump.

**speed during operation heating, hot water, cooling**

Setting range: auto / manual

Default value: auto

**Manual setting**

Setting range: 1 – 100 %

Default values: 70 %

**speed in wait mode**

Setting range: 1 – 100 %

Default values: 30 %

**max. allowed speed**

Setting range: 80 – 100 %

Default values: 100 %

Set the speed at which the charge pump is to operate in the present operating mode. Select "auto" if the speed of the charge pump is to be regulated automatically (factory setting) for optimal operation.

If "auto" is activated for heating operation, you can also make the setting "max. allowed speed" which restricts the charge pump and does not allow it to run at a higher speed than the set value.

For manual operation of the charge pump deactivate "auto" for the current operating mode and set the value to between 1 and 100 % (the previously set value for "max. allowed speed" no longer applies).

Speed in standby mode (only used if "auto" has been selected for "Operating mode") means the charge pump operates at the set speed during the time when there is neither a need for compressor operation nor additional heat.

**5.12 - country**

Select here where the product was installed. This allows access to country specific settings in your product.

Language settings can be made regardless of this selection.

**NOTE**

*This option locks after 24 hours, restart of display or program updating.*

# Service

## Operation control function by the indoor unit control

### Operation mode

#### General

The modes mentioned below can be chosen from the control panel.

Mode	Function
(1) Auto	<ul style="list-style-type: none"> <li>The mode is automatically switched over between (3) Heating mode and (4) Cooling mode. Automatic switching rule is mentioned below.</li> </ul>
(2) Manual	<ul style="list-style-type: none"> <li>In this operating mode, you can select what functions are permitted.</li> <li>You can't deselect "compressor" in manual mode.</li> </ul>
(3) Heating	<ul style="list-style-type: none"> <li>Hot water is supplied for heating.</li> <li>Hot water operation will be made when the tank water temperature lowers.</li> <li>When the outdoor unit can not cover the heat load, electric heater use is allowed and water in the tank is supplied for heating to fulfill the required heat load.</li> </ul>
(4) Cooling (Super Cooling)	<ul style="list-style-type: none"> <li>Cold water is supplied for cooling.</li> <li>Hot water operation will be made when the tank water temperature lowers;</li> </ul>
(5) Add. Heat only	<ul style="list-style-type: none"> <li>Outdoor unit is not allowed to operate.</li> <li>Only electric heater is exclusively used for Heating and Hot water operation.</li> </ul>

Note 1 : The measured value of outdoor air temperature (BT1) which is used for control, is averaged in accordance with the prescribed formula.

Note 2 : Heating/Cooling demand is calculated as numeric DM (Degree Minutes) from the supply water temperature (BT12) and its target temperature in accordance with the prescribed formula.

Note 3 : Electric heater can be replaced with external heat source of the docking feature. See Menu 5.1.12 and 5.3.6 for setting.

Note 4 : Two sets of climate system can be controlled with different heating curve. See Menu 1.9.1 for setting.

## Operation control function by the indoor unit control

## Actuator operation according to the operation mode

State	Function	Run status	Outdoor unit side			Indoor unit side			
			Compressor CM	Outdoor fan FMo1	4-way valve 20S	Electric heater EB1	Circulation pump GP12	Reversing valve QN10	Cooling shift valve QN12
Heating Alternating mode	Switching between heating and hot water	Heating	ON/OFF	ON/OFF	ON	OFF	Closed	ON	Closed
		Hot water					Active		Closed
Heating Combined mode	Outdoor unit produces heating and electric heater supports lack of capacity	Heating	ON	ON	ON	ON	Active	ON	Closed
Cooling	Switching between cooling and hot water	Cooling	ON/OFF	ON/OFF	OFF	OFF	Closed	ON	Open
		Hot water			ON		Active		Closed
Add. Heat only	Producing heating and hot water with electric heater	Heating	OFF	OFF	ON/OFF	ON	Closed	ON	Closed
		Hot water					Active		Closed
Defrost	Defrosting outdoor unit heat exchanger	Defrost	ON	OFF	OFF	ON	Closed	ON	Closed
		Tank defrost					Active		Closed
Shutdown	Only in the event of serious alarms	Stop	OFF	OFF	ON/OFF	OFF	Closed	ON/OFF	Closed

## Operation control function by the indoor unit control

### Mode transition in Auto mode

Change-over of Heating/Cooling operation is controlled by detection with outdoor air temperature sensor (BT1) of the indoor unit. Threshold value depends on setting on Menu 4.9.2.

#### Start cooling

If outdoor air temperature is above setting value on Menu 4.9.2, cooling mode is chosen.

If outdoor air temperature is below setting value on Menu 4.9.2 it switches to heating mode.

Default of setting value is 25°C .

#### Stop heating

If outdoor air temperature is below setting value on Menu 4.9.2, heating mode is chosen.

If outdoor air temperature is above setting value on Menu 4.9.2, it switches to cooling mode.

Default of setting value is 17°C .

### Mode transition in Auto/manual mode to hot water operation

Change-over of Heating or Cooling/Hot water operation is controlled by detection with temperature sensor (BT6) of the tank unit. Threshold value depends on setting on Menu 5.1.1.

#### Setting range start temp. economy/normal/luxury

If tank temperature is below setting value on Menu 5.1.1, hot water mode is chosen.

Default of setting value is the following table.

Hot operation mode	Default value
Economy	42°C
Normal	46°C
Luxury	49°C

#### Setting range stop temp. economy/normal/luxury

If tank temperature is above setting value on Menu 5.1.1, it switches to heating or cooling mode.

Default of setting value is the following table.

Hot operation mode	Default value
Economy	48°C
Normal	50°C
Luxury	53°C

Operation control function by the indoor unit control

### Supply water temperature control in heating

Target supply water temperature can be seen in Menu 1.1.

#### Heating curve

#### Heating/cooling curve setting

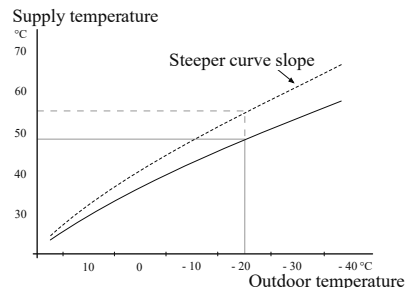
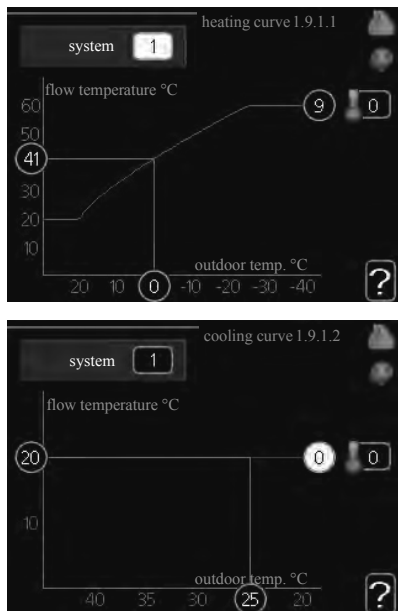

The optimum slope depends on the climate conditions in your location, the type of heating device (radiators or under floor heating) and how well insulated the house is.

The curve is set when the heating installation is installed, but may need adjusting later. Normally, the curve will not need further adjustment.

#### CAUTION

*In the event of making fine adjustments of the indoor temperature, the curve must be offset up or down instead, this is done in menu 1.1 "temperature".*

#### heating curve

Setting range: 0 – 15  
Default value: 9

#### cooling curve (accessory required)

Setting range: 0 – 9  
Default value: 0

The prescribed heating curve for your house can be viewed in the menu "heating curve". The task of the heating curve is to give an even indoor temperature, regardless of the outdoor temperature, and thereby energy efficient operation. From this heating curve, the control module determines the temperature of the water to the heating system, supply temperature, and therefore the indoor temperature. Select the heating curve and read off how the supply temperature changes at different outdoor temperatures here. If there is cooling function, the same settings can be made for the cooling curve.

#### Curve coefficient

The heating/cooling curve shows the relation between the target supply temperature and the corresponding outdoor temperature. A steep curve indicates that supply temperature becomes higher at low outdoor air temperature in heating and it becomes lower at high outdoor air temperature in cooling.

#### Curve offset

The target temperature can be offset in parallel over the entire outdoor temperature range by this function. This is offset by 5 °C by adjusting 2 steps.

The target temperature can be parallel offset in the entire outdoor temperature range with this function. It is offset by 5 °C by adjusting 2 steps.

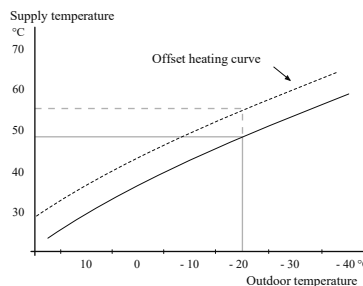

**Operation control function by the indoor unit control**

**Flow line temperature – maximum and minimum values**

This function is used in order to limit max-min supply temperature. The heating / cooling curve becomes flat beyond max / min target temperature.

**CAUTION**

*Underfloor heating systems are normally "max flow line temperature" set between 35 and 45°C. Take care not to cause low temperature burns in case it is set higher than 35°C.*

*Must be restricted with underfloor cooling min. flow line temp. to prevent condensation.*

*Check the max temperature for your floor with your installer/floor supplier.*

**TIP**

*Wait 24 hours before making a new setting, so that the room temperature has time to stabilise.*

*If it is cold outdoors and the room temperature is too low, increase the curve slope by one increment.*

*If it is cold outdoors and the room temperature is too high, lower the curve slope by one increment.*

*If it is warm outdoors and the room temperature is too low, increase the curve offset by one increment.*

*If it is warm outdoors and the room temperature is too high, lower the curve offset by one increment.*

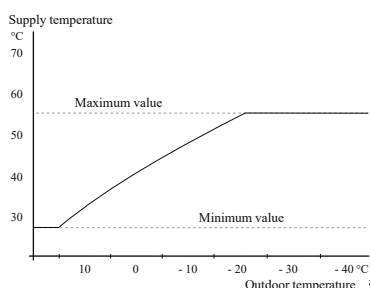

The figure at the end of the curve indicates the curve number. The figure beside the thermometer icon gives the curve offset. Use the control knob to set a new value.

Confirm the new setting by pressing the OK button.

Curve 0 is an own curve created in menu 1.9.7.

**To select another curve (slope):**

1. Press OK button to access the setting mode
2. Select a new curve. The curves are numbered from 0 to 15, and the bigger number curve has steeper slope. Curve 0 means that "own curve" (menu 1.9.7) is used.
3. Press OK button to exit the setting.

**To read off a curve:**

1. Turn the control knob so that the ring on the shaft with the outdoor temperature is marked.
2. Press OK button.
3. Follow the grey line up to the curve and out to the left to read off the value for the supply temperature at the selected outdoor temperature.
4. You can now select to take read outs for different outdoor temperatures by turning the control knob to the right or left and read off the corresponding flow temperature.
5. Press OK or Back button to exit read off mode.



**Water temperature control when deviated from the target**

When the DM value is significantly small, supply water temperature must be controlled higher than target temperature to reduce the deficit of DM value. However, too big overshoot of the supply temperature will affect comfort.

In order to control the supply water temperature to avoid fluctuation of room temperature, overshoot limit is set in Menu 5.1.3 (Max diff flow-line temp.). When the current supply temperature deviates from the set value compared to that calculated, the heat pump is forced to stop irrespective of the degree minute value.

If the current supply temperature exceeds the calculated flow temperature plus the set value, the degree minute value is set to 0. The compressor in the heat pump stops when there is only a heating demand.

**Heating thermo-ON / OFF control**

The control by DM value is the basic principle to operate/stop the outdoor unit operation.

**DM (Degree-Minutes) value**

DM value is integrated value of the gap between the target and actual supply water temperature.

Compressor required speed and electric heater ON/OFF are controlled by the DM value.

**Operation state transition according to DM value**

According to the DM value, operating state is changed.

Default of DM start heating value (Menu 4.9.3) is -60.

Default of DM start add. heat value (Menu 4.9.3) is 400.

**Supply water temperature control in cooling**

Principle such as cooling curve, cooling curve offset and upper/lower limit is the same as heating operation.

Target supply water temperature can be checked in Menu 1.9.

Cooling curve can be chosen in Menu 1.9.1.2.

**Cooling curve**

Cooling curve is the basic principle to decide the target supply water temperature for cooling.

The higher the outdoor air temperature (BT1) becomes, the lower the target supply water temperature becomes, and the characteristics can be adjusted in Menu 1.9.1.2.

**Upper/Lower limit of the supply water temperature**

Regardless of the cooling curve setting and the outdoor air temperature, target supply water temperature can not exceed the min/max supply water temperature set in Menu 1.9.3.2 and 5.1.2.

Upper and lower limit is set after various offset correction.

**Water temperature control when deviated from the target**

When the DM value is significantly big, supply water temperature must be controlled lower than target temperature to reduce the surplus of DM value. However, too big overshoot of the supply temperature will affect comfort.

In order to control the supply water temperature to avoid fluctuation of room temperature, overshoot limit is set in Menu 9.6.7 (Max diff flow-line temp.). When the current supply temperature deviates from the set value compared to that calculated, the heat pump is forced to stop irrespective of the degree minute value.

If the current supply temperature exceeds the calculated flow temperature plus the set value, the degree minute value is set to 0. The compressor in the heat pump stops when there is only a heating demand.

**Cooling thermo-ON / OFF control**

Principle of the control such as DM value is the same as heating operation.

**DM (Degree-Minutes) value**

DM value is limited in Menu 1.9.5 and does not exceed the limit.

**Operation state transition according to DM value**

According to the DM value, operating state is changed.

Default of DM start cooling value (Menu 1.9.5) is +30.

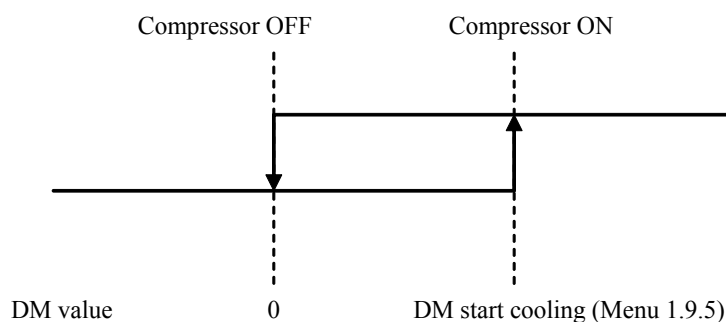
**Exceptional processing of DM value**

Forced outdoor unit operation

In cooling mode, there is no exceptional DM value processing to operate the outdoor unit according to the gap between target and actual supply water temperature.

Forced outdoor unit stop

In case the actual supply water temperature is lower than the target temperature and the gap is bigger than the value set in Menu 5.1.3 when the outdoor unit is operating, the DM value is overwritten to 0, which results in stopping the outdoor unit operation immediately.

## Operation control function by the indoor unit control

### Hot water operation control

#### **ON/OFF control**

Regardless of the DM value, hot water operation when tank water temperature (BT6) lowers below Start temp HW in Menu 5.1.1. It finishes when the tank water temperature reaches Stop temp HW in Menu 5.1.1.

#### **Compressor speed control**

During the hot water operation, compressor speed is controlled according to the map linked with the outdoor air temperature. There are two maps. One is high cap map. The other is low cap. These map automatically changed depending on the tank temperature.

#### **Charge method**

There are two kinds of hot water storage methods. The 2 methods are dt and target temperature charging. They can be chosen in Menu 5.1.1. Dt uses high capacity curve when BT12, BT3 and BT6 allow it and finish the charging with low capacity curve. Target temperature method uses high capacity curve only.

#### **Defrost operation**

When frost accumulates on the surface of the outdoor heat exchange, defrost operation starts to remove it. For detailed operation condition, see outdoor unit control

During defrost operation, indoor unit operates as follows in order to extract heat from the heating system:

- Reversing valve QN10 and QN12 are towards heating system.
- Circulation pump GP12 keeps operation based on general rule.

When at least one of the following conditions is fulfilled, Reversing valve QN12 switches towards hot water to extract heat from the tank.

- Water return temperature < tank defrost temperature level
- Water outlet temperature < 10°C
- Water return temperature – Water outlet temperature > Min Flow Threshold
- Operation of the climate system has been blocked

### Protection control

#### **Current protection**

Maximum current limit control for the outdoor unit (by indoor unit control)

When the operation current of the outdoor unit comes close to the limit, request compressor speed is retained in order to keep the current.

#### **Freeze protection of water heat exchanger**

The freeze protection function shall avoid water to freeze inside the heat exchanger during defrost and cooling operation.

##### (1) In cooling mode

Compressor speed is kept when the low pressure (BP4) reaches 0.75MPa, and stopped when it reaches 0.65MPa for 20 seconds. Operation is automatically restarted when it reaches 0.83MPa and the supply water temperature becomes 14°C or higher, but it will permanently stop if the protection is activated for 10 repeated.

##### (2) In defrosting mode

Compressor stops when the low pressure (BP4) reaches threshold value for 10 seconds depending on water temperature.

After stopping, the system automatically restarts with heating mode.

When the above action is repeated for 10 times, the system stops and error code is displayed.

#### **Low condenser out**

Compressor stops when the supply temperature (BT12) becomes below 5°C and it automatically restarts when the supply temperature (BT12) becomes above 14°C.

#### **High water out**

Compressor stops when the supply temperature (BT12) becomes above 60°C and it automatically restarts when the supply temperature (BT12) becomes below 58°C.

#### **High water in**

Compressor stops when the return temperature (BT3) becomes above 55°C and it automatically restarts when the return temperature (BT3) becomes below 53°C.

#### **High pressure**

Compressor stops when the high pressure (BP4) reaches 4.15MPa and it automatically restarts when the high pressure (BP4) becomes below 3.15MPa.

When the above action is repeated for 5 times within an hour, the system will permanently stop.

## Operation control function by the outdoor unit control

### Determination of compressor speed (frequency)

- 1) Maximum and minimum frequency under normal operating conditions

(rps)

Model	FDCW60VNX-W	
Operation mode	Cooling	Heating
Maximum frequency	106	110
Minimum frequency	12	12

- 2) Maximum required frequency under high outdoor air temperature condition

Maximum required frequency is limited according to the outdoor air temperature (Tho-A)

(rps)

Model	FDCW60VNX-W	
Cooling mode	A rps	60
	B rps	75
	C rps	90
	D rps	Please see 3)
	E rps	95
Heating mode	A rps	90
	B rps	75

<Cooling mode>

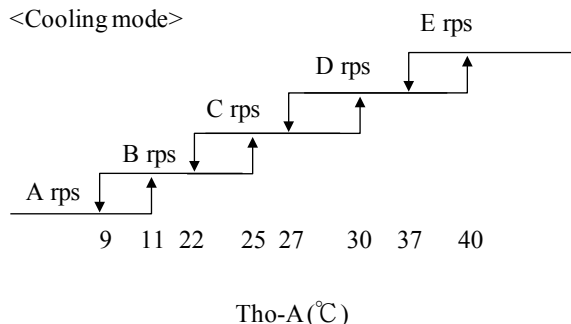

<Heating mode>

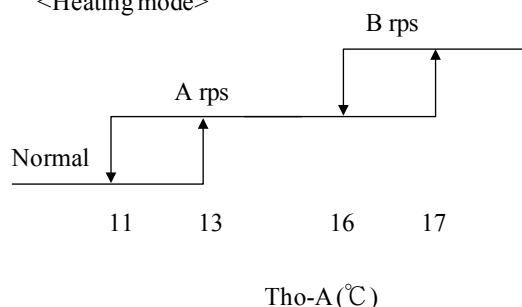

- 3) Maximum frequency under high condensing saturated temperature (CST or Thi-L whichever higher) in heating mode.

Maximum frequency is limited according to the condensing saturated temperature.

(rps)

Model	FDCW60VNX-W	
Cooling mode	Outdoor air temperature	27°C < Tho-A ≤ 40°C
	A rps	95
	B rps	-

(rps)

Model	FDCW60VNX-W			
Heating mode	Outdoor air temperature	Tho-A < 0°C	0°C ≤ Tho-A	
	A rps	95	90	
	B rps	Normal	100	

<Cooling mode>

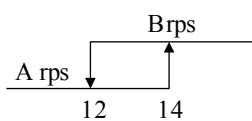

CST or Thi-L whichever higher

<Heating mode>

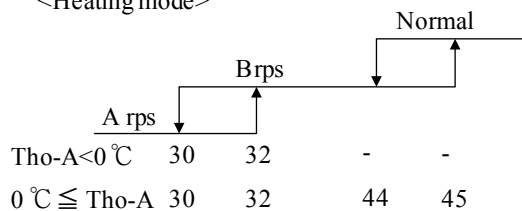

CST or Thi-L whichever higher

**Operation control function by the outdoor unit control**

- 4) Minimum required frequency under high ambient temperature condition.  
According to the outdoor air temperature (Tho-A), minimum required frequency in cooling mode is changed as per A or B in below table.

Model		FDCW60VNX-W
Cooling mode	A rps	30
	B rps	40
Heating mode	A rps	30
	B rps	40

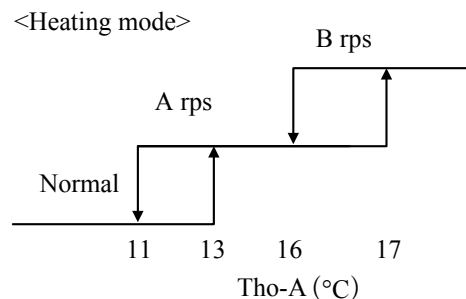
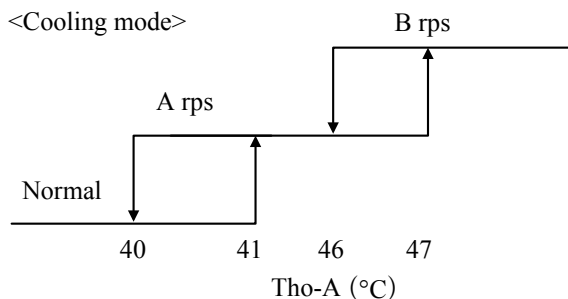

- 5) Minimum required frequency adjustment under low ambient temperature (Tho-A) condition  
According to the outdoor air temperature, minimum required frequency is offset by as per below table.

Model		FDCW60VNX-W
Cooling mode	A rps	-
	B rps	45
Heating mode	A rps	35
	B rps	45

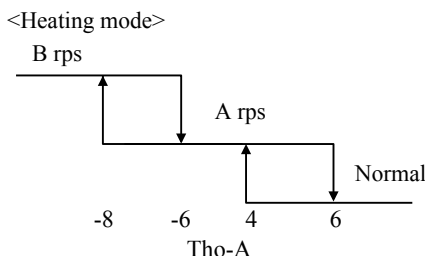
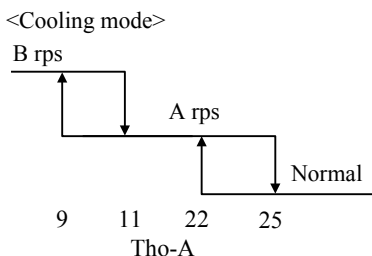

- 6) Minimum required frequency under high condensing saturated temperature (CST or Thi-L whichever higher) in heating mode.

Model		FDCW60VNX-W
Heating mode	A rps	41

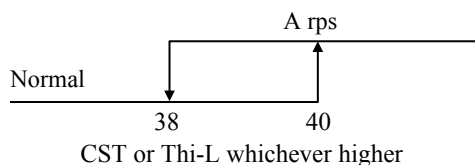

- 7) When any of the controls from 1) - 6) above may duplicate, whichever the smallest value among duplicated controls is taken as the maximum required frequency, and whichever the biggest value is taken as the minimum required frequency.

**Compressor start control**

- 1) Compressor starts upon receipt of the thermostat ON signal from the indoor unit
- 2) However, at initial start-up after turning the power circuit breaker on, the compressor may enter the standby state for maximum 30 minutes in order to prevent from dry-up of oil in the compressor.

**Operation control function by the outdoor unit control**

**Compressor soft start control**

1) The pattern 1

Normally, the outdoor unit starts a compressor with this control except the condition mentioned in (2) pattern 2.

- Firstly, compressor starts at 10rps up to the target speed "30rps", and it is accelerated by 5rps/s.
- Compressor acceleration
- The compressor upper limit speed is limited at "A", "B", and "C" rps for "T minutes after compressor starts" respectively.

		Duration from the starting compressor T (min)				
		T ≤ 5min	T ≤ 7min	T ≤ 9min	T > 9min	
		A rps	B rps	C rps		
FDCW60VNX-W	Cooling mode	120	120	120	-	
	Heating mode	Tho-A ≥ 0°C	48	120	120	-
		Tho-A < 0°C	48	56	75	-

“When the value in this table is higher than the global highest (Nmaxo) value, it follows the global highest value.”

In case the pattern 1 condition and the pattern 3 condition are fulfilled at the same time, pattern 3 start-up will be done.

2) The pattern 2

① Control condition

Operation mode is “Heating” and all below condition a) and b) are fulfilled.

But any of 1) ~3) conditions is fulfilled, pattern 1 start-up will be done.

- 1) Operation mode is changed from “stop” to “Heating”
  - 2) Restarting compressor after Defrost operation.
  - 3) Restart from “Forced-Stop”
- a) “Compressor Command” is turned from “OFF” to “ON”
- b) When “Compressor commnad” is turned “ON”, Tho-A is less than 10 degree C.

				Duration from the starting compressor T (min)		
				T ≤ 1min	T ≤ 5min	T ≤ 5min
				A rps	B rps	C rps
FDCW60VNX-W	Heating mode	TAi < 35°C	Tho-A ≥ -5°C	40	32	-
			Tho-A < -5°C	45	32	-
		TAi > 35°C	-	48	48	-

※ TAI; Inlet water temperature

3) The pattern 3

① Control condition

In case all of the following conditions are fulfilled when the operation mode is not "Stop"

- i) Inverter command changes from "STOP" to "RUN".
- ii) Target compressor speed is less than A rps.

② Control contents

Compressor lower speed limit is limited at Arps for "a" minutes.

	Mode	A rps	a min
FDCW60VNX-W	Cooling	40	3
	Heating	41	3

If the operation is duplicate the pattern 2 and the pattern 3, the pattern 2 execution is priority.

**Operation control function by the outdoor unit control**

**Outdoor fan control**

1) Relations between Fan speeds and revolutions

			Fan speed (rpm)							
			1st	2nd	3rd	4th	5th	6th	7th	8th
FDCW60VNX-W	Revolutions	Cooling	150	225	485	520	570	685	740	850
		Heating	150	225	485	520	570	685	800	850

2) Control of fan motor speed

(a) Starting fanmotor speed is fixed by the fanmotor speed excepted below case (i)

(i) Operation mode is “cooling” and Tho-A < 22°C

	Fan speed	Control duration
11°C ≤ Tho-A < 22°C	2nd	30second after “Compressor ON”
Tho-A < 11°C	1st	30second after “Compressor ON”

If Tho-A changed the condition during 30second, Fan speed does not change.

(ii) Other than case (i)

Follow the table (2).(b)

(b) Control of the fan motor speed in normal mode

		Fan speed (rpm)								
		OFF	1st	2nd	3rd	4th	5th	6th	7th	8th
Compressor speed (rps)	Cooling	0	-	-	-	0-22	22-30	30-58	58-80	80-
	Heating	0	-	-	-	0-30	30-38	38-78	78-90	90-

※ Fan motor speed down actually delays 60 second from the time that the each change command occurs.

Once the increase command is active even if it is within the above 60 seconds,the fan speed is increased promptly.

※※ When fan motor speed command “OFF” is active, fan motor speed is controlled 0 rpm promptly without delay.

3) Stop fanspeed control.

Fan stop control shows as follows.

① Fan motor stops after fan 6th speed is operated T minutes.

	T (minutes)
Cooling	1min
Heating	1min

4) Fan speed control during cooling operation

a) Ambient air temperature (Tho-A) is below 25°C .

Fan motor speed operates theUp-Down control according to heat exchanger temperature (Tho-R).

Tho-R	Fan speed
Tho-R ≤ 21°C	Decreased by 1 speed
21°C < Tho-R ≤ 38°C	Retained
38°C < Tho-R	Increased by 1speed

**Operation control function by the outdoor unit control**

b) Ambient air temperature (Tho-A) is above 41°C .

Fan motor speed operates the Up control according to ambient air temperature (Tho-A).

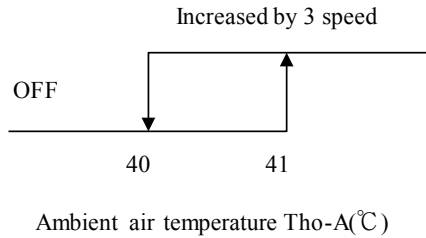

5) Fan speed control during normal heating operation

a) Ambient air temperature (Tho-A) is below 4°C .

Fan motor speed operates the Up control according to ambient air temperature (Tho-A).

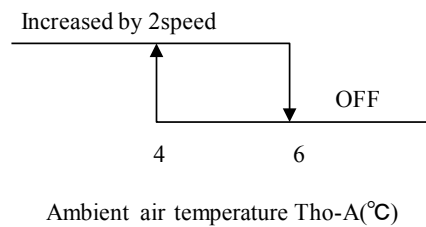

b) Heat exchanger temperature (Tho-R) is above 13°C .

Fan motor speed operates the Down control according to heat exchanger temperature (Tho-R).

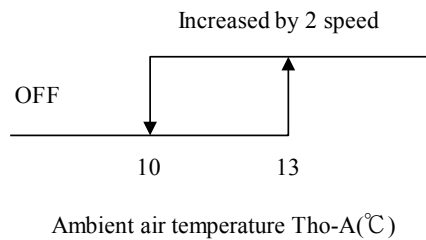



## Silent mode

When outdoor unit receives silent mode signal from indoor unit, silent mode operation starts.

[Control contents]

- a) Fan speed upper limits are restricted according to the following table.

Model	Operation mode	Max speed (rpm)
FDCW60VNX-W	Heating / Cooling	570

\* Compressor speed limits are also restricted by indoor unit control command.

\* In case of some conditions which enter protection control, the restriction of silent mode is cancelled.

**Operation control function by the outdoor unit control**

**Defrost operation**

- 1) Defrost starting conditions  
 Defrost operation can be started only when all of the following condition are satisfied.
  - a) After start of heat operation  
 When it elapsed 35 minutes.(Accumulated compressor operating time)
  - b) After end of defrost operation  
 When it elapsed 35 minutes.(Accumulated compressor operation time)
  - c) Outdoor heat exchanger sensor (Tho-R) temperature  
 When the temperature has been below -5 °C for 3 minutes continuously.
  - d) The difference between the outdoor air temperature sensor and the outdoor heat exchanger temperature sensor (Tho-A - Tho-R) fulfils the following condition.
    - Tho-A - Tho-R ≥ 7°C

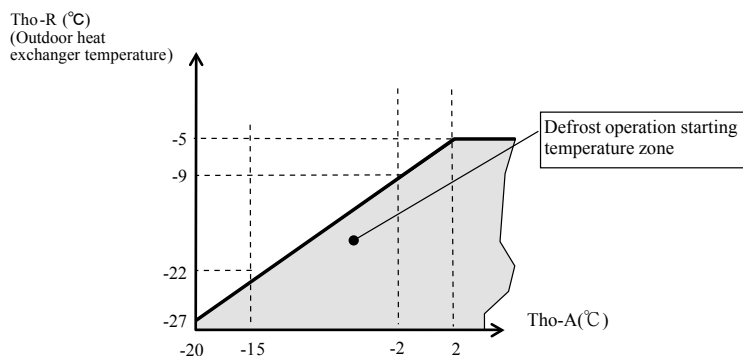

- 2) Defrost ending conditions  
 Defrost ending condition is fulfilled when either one of the following is satisfied.
  - a) Outdoor heat exchanger temperature sensor (Tho-R):10°C or higher
  - b) Control operation time of defrost operation→When 16 minutes 35 seconds has passed since 4-way valve is switched.

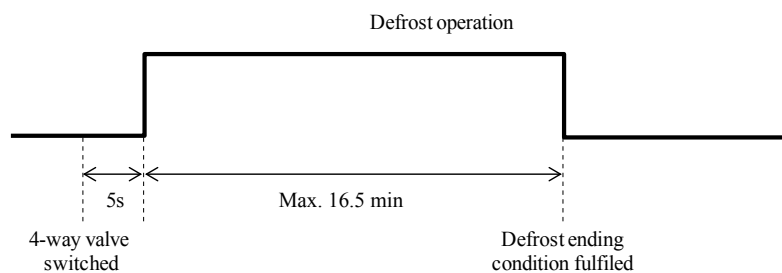

**Operation control function by the outdoor unit control**

**Protective control/ anomalous stop control by compressor speed (frequency)**

1) Compressor discharge pipe temperature protection

a) Protective control

If the discharge pipe temperature (detected with Tho-D) exceed the setting value, the compressor speed (frequency) is controlled in order to suppress the rise of discharge pipe temperature.

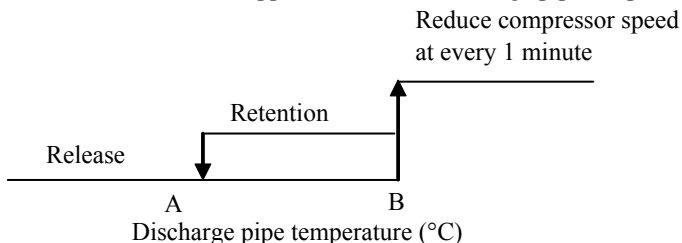

Model	A°C	B°C
FDCW60VNX-W	95	105

b) Anomalous stop control

- i) If the discharge pipe temperature (detected with Tho-D) exceed the setting value, the compressor stops.
- ii) When the discharge pipe temperature anomaly is detected 2 times within 60 minutes or 60 minutes continuously including the time of compressor stopping, discharge pipe temperature error is displayed and E36 is recorded in Error Log and it enters the anomalous stop mode.

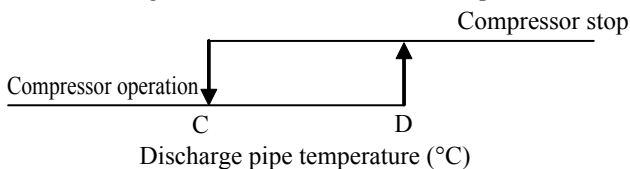

Model	C°C	D°C
FDCW60VNX-W	95	115

c) Reset of anomalous stop mode

When the discharge pipe temperature drops to the reset value of E°C or lower for F minutes continuously, it becomes possible to restart from control.

Model	FDCW60VNX-W
E °C	95
F minutes	Immediately

2) Cooling high pressure protection

a) Protective control

- i) When the outdoor heat exchanger temperature (Tho-R) exceeds setting value that be changed by outdoor air temperature, the compressor speed (frequency) is controlled in order to suppress the rise of high pressure.

Model		FDCW60VNX-W	
		A zone	B zone
Cooling mode	P1	51	53
	P2	53	58
	P3	56	63

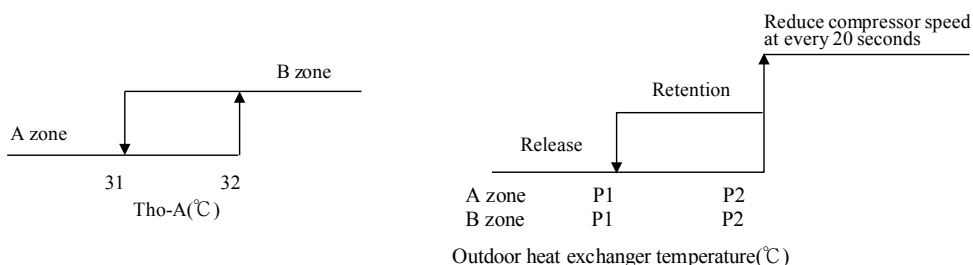

**Operation control function by the outdoor unit control**

b) Anomalous stop control

- i) If the outdoor heat exchanger temperature (Tho-R) exceeds the setting value, the compressor stop.
- ii) When the outdoor heat exchanger temperature anomaly is detected 5 times within 60 minutes, or 60 minutes continuously including the time of compressor stopping, coolinf overload error is displayed and E35 is recorded in the Error Log and it enters the anomalous stop mode.

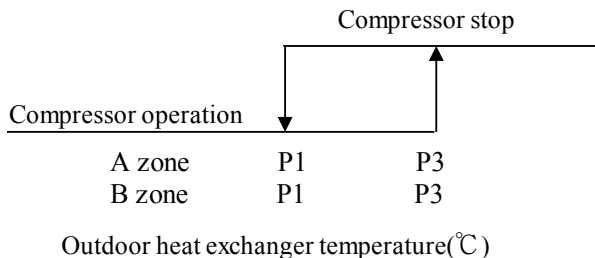

c) Reset of anomalous stop mode

When the outdoor heat exchanger temperature drops to the reset value P3 °C or lower, it becomes possible to restart from the control.

3) Heating high pressure protection

a) Protective control

If the liquid line temperature of water heat exchanger (BT15=Thi-L) or the condensing saturated temperature (CST), whichever the higher.

Exceeds the setting value, the compressor speed (frequency) is controlled at every 10 seconds to suppress the rise of high pressure.

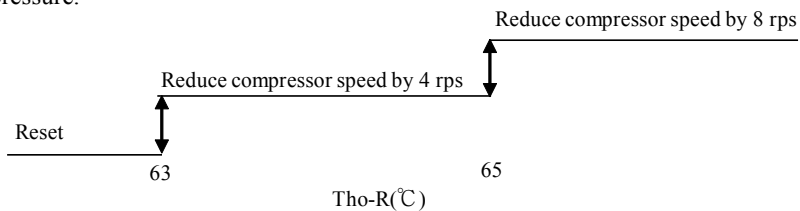

**Operation control function by the outdoor unit control**

4) Overcurrent protection

When the inverter primary current (CT current) reaches following value, the compressor speed is reduced until it gets to the cancellation value.

Operation mode	Current (A)
Cooling	11.5
Heating	13.5

5) Anomalous power transistor current

a) If the current value of power transistor exceeds the setting value, the compressor stops in order to prevent from overcurrent of inverter.

6) Anti-freeze control by the compressor frequency control

It depends on the command from indoor unit.

7) Broken wire detection on temperature sensor and low pressure sensor

a) Outdoor heat exchanger temperature sensor, outdoor air temperature sensor

If the following is detected for 5 seconds continuously within 2 minutes to 2 minutes 20 seconds after the compressor ON, the compressor stops. After a delay of 3 minutes, the compressor restarts but if the same anomaly is detected repeatedly 3 times within 40 minutes, the compressor stops with the anomalous stop mode.

- Outdoor heat exchanger temperature sensor (Tho-R): -50°C or lower
- Outdoor air temperature sensor (Tho-A): -30°C or lower

Note : During defrost operation and for 3 minutes after the end of defrost operation, this control is not performed.

b) Discharge pipe temperature sensor

If the following is detected for 5 seconds continuously within 10 minutes to 10 minutes 20 seconds after the compressor ON, the compressor stops. After a delay of 3 minutes, the compressor restarts but if the same anomaly is detected repeatedly 3 times within 40 minutes, the compressor stops with the anomalous stop mode.

- Discharge pipe temperature sensor (Tho-D): -10°C or lower

Note : During defrost operation and for 3 minutes after the end of defrost operation, this control is not performed.

8) Fan motor error

a) If the outdoor fan speed is detected A rpm or lower for 30 seconds continuously under the outdoor fan control mode, the compressor stops.

b) When the outdoor fan speed drops to A rpm or lower 3 times and the compressor stops, Fan alarm is displayed and E48 is recorded in the Error Log.

Model	FDCW60VNX-W
A rpm	75

9) Anomalous stop by the compressor start/stop

a) When it fails to shift to the rotor position detection operation of compressor DC motor during 5 seconds after establishing the compressor start condition, the compressor stops temporarily and restarts 3 minutes later.

## Operation control function by the outdoor unit control

### Pump-down control

It is possible to recover the refrigerant on the piping into the outdoor unit by this function.

Pump down operation can only be started when operation mode is set to addition heat only on menu 4.2. When this operating mode is activated pump down is available on service menu 5.11.

Menu number	Setting	Alternatives	Default	Other
5.11.X.1	Pump down	Yes/No	No	Menu only displayed in “Addition heat only” mode
5.11.X.2	Start pump down	Yes/No	No	Activates compressor operation. Above menu has to set “Yes” to display this menu.

Once the function has been activated:

- Compressor starts cooling operation with 2 minutes delay time.
- Target compressor speed will be 56 rps.
- Circulation pump runs at 100% when compressor starts.

Pump down stops automatically when one of the following conditions is fulfilled:

- Pressure at BP4 gets lower more than 0.087MPa for more than 5 seconds.
- More than 5 minutes have passed.
- An alarm stops the compressor operation.

When pump down is stopped:

- Circulation pump runs at it normal operation.
- Pump down changes to “No”.
- Start pump down changes to “No”.

## Alarm list

Alarm No.	Alarm text on the display	Description	May be due to
157	Low lp cooling	Protection against freezing in water HX during cooling operation	<ul style="list-style-type: none"> <li>■ Low/no water flow</li> </ul>
162	High condenser out temperature	Too high temperature out from the condenser. Self-resetting.	<ul style="list-style-type: none"> <li>■ Low flow during heating operation</li> <li>■ Too high set temperatures</li> </ul>
163	High condenser in temperature	Too high temperature into the condenser. Self-resetting.	<ul style="list-style-type: none"> <li>■ Temperature generated by another heat source</li> </ul>
183	Defrosting in progress	Not an alarm, but an operating status.	<ul style="list-style-type: none"> <li>■ Set when the heat pump runs the defrosting procedure</li> </ul>
220	High pressure alarm	BP4 has been above 4,15MPa 5 times within 60 minutes.	<ul style="list-style-type: none"> <li>■ Insufficient air circulation or blocked heat exchanger</li> <li>■ Expansion valve not correctly connected</li> <li>■ Service valve closed</li> <li>■ Defective control board in FDCW</li> <li>■ Low or no flow during heating operation</li> <li>■ Defective circulation pump</li> <li>■ Defective fuse, F(4A)</li> </ul>
224	Fan alarm from heat pump	Deviations in the fan speed in FDCW.	<ul style="list-style-type: none"> <li>■ The fan cannot rotate freely</li> <li>■ Defective control board in FDCW</li> <li>■ Defective fan motor</li> <li>■ Control board in FDCW dirty</li> <li>■ Fuse (F2) blown</li> </ul>
228	Failed defrosting	10 aborted defrost due to alarm: 418,419 or 343	<ul style="list-style-type: none"> <li>■ Too low water flow</li> <li>■ Too low return temperatur</li> </ul>
230	Hot gas alarm	Temperature deviation on the hot gas sensor (Tho-D) twice within 60 minutes or for 60 minutes continuously.	<ul style="list-style-type: none"> <li>■ Sensor does not work (see section "Ambient temperature sensor")</li> <li>■ Insufficient air circulation or heat exchanger</li> <li>■ Blocked</li> <li>■ If the fault persists during cooling, there may be an insufficient amount of refrigerant.</li> <li>■ Defective control board in FDCW</li> </ul>
261	High HWX temp	Temperature deviation on the heat exchanger sensor (Tho-R1/R2) five times within 60 minutes or for 60 minutes continuously.	<ul style="list-style-type: none"> <li>■ Sensor does not work (see section "Disturbances in comfort")</li> <li>■ Insufficient air circulation or blocked heat exchanger</li> <li>■ Defective control board in FDCW</li> <li>■ Too much refrigerant</li> </ul>
262	Inv. err.	When IPM (Intelligent power module) displays FO-signal (Fault Output) five times during a 60-minute period.	Can occur when 15V power supply to the inverter PCB is unstable.

Alarm No.	Alarm text on the display	Description	May be due to
263	Inv. err.	Voltage from the inverter outside the parameters four times within 30 minutes.	<ul style="list-style-type: none"> <li>■ Incoming power source interference</li> <li>■ Service valve closed</li> <li>■ Insufficient amount of refrigerant</li> <li>■ Compressor fault</li> <li>■ Defective circuit board in FDCW</li> </ul>
265	Inv. err.	Continuous deviation on power transistor for 15 minutes.	<ul style="list-style-type: none"> <li>■ Defective fan motor</li> <li>■ Defective circuit board in FDCW</li> </ul>
267	Inv. err.	Failed start for compressor	<ul style="list-style-type: none"> <li>■ Defective circuit board in FDCW</li> <li>■ Defective control board in FDCW</li> <li>■ Compressor fault</li> </ul>
268	Inv. err.	Overcurrent, Inverter A/F module	<ul style="list-style-type: none"> <li>■ Sudden power failure</li> </ul>
271	Lw otd tmp	Temperature of BT28 below the value that permits operation	<ul style="list-style-type: none"> <li>■ Cold weather conditions</li> <li>■ Sensor fault</li> </ul>
272	High otd tmp	Temperature of BT28 above the value that permits operation	<ul style="list-style-type: none"> <li>■ Warm weather conditions</li> <li>■ Sensor fault</li> </ul>
277	Sensor fault from heat pump	Sensor fault, heat exchanger in FDCW(Tho-R).	<ul style="list-style-type: none"> <li>■ Open circuit or short circuit on sensor input</li> <li>■ Sensor does not work (see section "Disturbances in comfort")</li> <li>■ Defective control board in FDCW</li> </ul>
278	Sensor fault from heat pump	Sensor fault, outdoor temperature sensor in FDCW (Tho-A).	<ul style="list-style-type: none"> <li>■ Open circuit or short circuit on sensor input</li> <li>■ Sensor does not work (see section "Disturbances in comfort")</li> <li>■ Defective control board in FDCW</li> </ul>
279	Sensor fault from heat pump	Sensor fault, hot gas in FDCW (Tho-D).	<ul style="list-style-type: none"> <li>■ Open circuit or short circuit on sensor input</li> <li>■ Sensor does not work (see section "Disturbances in comfort")</li> <li>■ Defective control board in FDCW</li> </ul>
294	Incompatible heat pump	Heat pump and indoor module do not work properly together due to technical parameters.	<ul style="list-style-type: none"> <li>■ Outdoor module and indoor module are not compatible.</li> </ul>
343	Low temp water out	Low water out temperature during cooling or tank defrost operation	<ul style="list-style-type: none"> <li>■ Too low water flow</li> <li>■ Too low return temperatur</li> </ul>
347	Temp high press	Temporary high pressure alarm	<ul style="list-style-type: none"> <li>■ No/low water flow</li> <li>■ Air in water system</li> </ul>
403	Sensor fault from PCA 154	Sensor fault, Sensor incoming water in indoor unit (BT3).	<ul style="list-style-type: none"> <li>■ Open circuit or short circuit on sensor input</li> <li>■ Sensor does not work (see section "Disturbances in comfort")</li> <li>■ Defective control board AA23 in indoor unit.</li> </ul>



Alarm No.	Alarm text on the display	Description	May be due to
404	Sensor fault from PCA 154	Sensor fault, Sensor high pressure heating/ low pressure cooling in indoor unit (BP4).	<ul style="list-style-type: none"> <li>■ Open circuit or short circuit on sensor input</li> <li>■ Sensor does not work (see section "Disturbances in comfort")</li> <li>■ Defective control board AA23 in indoor unit.</li> </ul>
412	Sensor fault from PCA 154	Sensor fault, Sensor outgoing water in indoor unit (BT12).	<ul style="list-style-type: none"> <li>■ Open circuit or short circuit on sensor input</li> <li>■ Sensor does not work (see section "Disturbances in comfort")</li> <li>■ Defective control board AA23 in indoor unit.</li> </ul>
415	Sensor fault from PCA 154	Sensor fault, Sensor fluid pipe in indoor unit (BT15).	<ul style="list-style-type: none"> <li>■ Open circuit or short circuit on sensor input</li> <li>■ Sensor does not work (see section "Disturbances in comfort")</li> <li>■ Defective control board AA23 in indoor unit.</li> </ul>
418	Low temp water out	Anti-freeze protection water heat exchanger during defrost operation.	<ul style="list-style-type: none"> <li>■ Too low water flow</li> </ul>
419	Freeze prot. exch. defr.	Anti-freeze protection water heat exchanger during defrost operation.	<ul style="list-style-type: none"> <li>■ Too low water return temperature</li> </ul>

## Outdoor unit alarm

Alarm No.	Alarm text on the display	Description	May be due to
E5	Com. flt from the heat pump	Communication between the control board and the communication board is interrupted. There must be 22 Volt direct current (DC) at the switch CNW2 on the control board (PCB1).	<ul style="list-style-type: none"> <li>- Any circuit breakers for FDCW off</li> <li>- Incorrect cable routing</li> </ul>
E35	High HWX temp	Temperature deviation on the heat exchanger sensor (Tho-R1/R2) five times within 60 minutes or for 60 minutes continuously.	<ul style="list-style-type: none"> <li>- Sensor does not work (see section "Disturbances in comfort")</li> <li>- Insufficient air circulation or blocked heat exchanger</li> <li>- Defective control board in FDCW</li> <li>- Too much refrigerant</li> </ul>
E36	Hot gas alarm	Temperature deviation on the discharge pipe temperature sensor (Tho-D) twice within 60 minutes or for 60 minutes continuously.	<ul style="list-style-type: none"> <li>- Sensor does not work (see section "Ambient temperature sensor")</li> <li>- Insufficient air circulation or heat exchanger</li> <li>- Blocked</li> <li>- If the fault persists during cooling, there may be an insufficient amount of refrigerant.</li> <li>- Defective control board in FDCW</li> </ul>
E37	Sensor fault from heat pump	Sensor fault, heat exchanger in FDCW(Tho-R).	<ul style="list-style-type: none"> <li>- Open circuit or short circuit on sensor input</li> <li>- Sensor does not work (see section "Disturbances in comfort")</li> <li>- Defective control board in FDCW</li> </ul>
E38	Sensor fault from heat pump	Sensor fault, outdoor air temperature sensor in FDCW (Tho-A).	<ul style="list-style-type: none"> <li>- Open circuit or short circuit on sensor input</li> <li>- Sensor does not work (see section "Disturbances in comfort")</li> <li>- Defective control board in FDCW</li> </ul>
E39	Sensor fault from heat pump	Sensor fault, hot gas in FDCW (Tho-D).	<ul style="list-style-type: none"> <li>- Open circuit or short circuit on sensor input</li> <li>- Sensor does not work (see section "Disturbances in comfort")</li> <li>- Defective control board in FDCW</li> </ul>
E40	High pressure alarm	BP4 has been above 4.15MPa 5 times within 60 minutes.	<ul style="list-style-type: none"> <li>- Insufficient air circulation or blocked heat exchanger</li> <li>- Expansion valve not correctly connected</li> <li>- Service valve closed</li> <li>- Defective control board in FDCW</li> <li>- Low or no flow during heating operation</li> <li>- Defective circulation pump</li> <li>- Defective fuse, F(4A)</li> </ul>
E42	Current cut	When IPM(Intelligent power module) detects abnormally high current.	<ul style="list-style-type: none"> <li>- Incoming power supply interference</li> <li>- Service valve closed</li> <li>- Insufficient amount of refrigerant</li> <li>- Compressor fault</li> <li>- Defective circuit board for inverter in FDCW</li> </ul>

<b>Alarm No.</b>	<b>Alarm text on the display</b>	<b>Description</b>	<b>May be due to</b>
E47	Inv. err.	Overcurrent, Inverter A/F module	- Sudden power failure
E48	Fan alarm from heat pump	Deviations in the fan speed in FDCW	- The fan cannot rotate freely - Defective control board in FDCW - Defective fan motor - Control board in FDCW dirty - Fuse (F2) blown
E51	Inv. err.	Continuous deviation on power transistor.	- Defective fan motor - Defective circuit board for inverter in FDCW
E59	Inv. err.	Failed start for compressor	- Defective circuit board for inverter in FDCW - Defective control board in FDCW - Compressor fault
E60	Rotor lock	If the compressor motor's magnetic pole positions cannot be correctly detected when the compressor starts	- Open phase compressor - Defective PCB in FDCW - Compressor fault

# Troubleshooting guide

## 220 - High pressure alarm

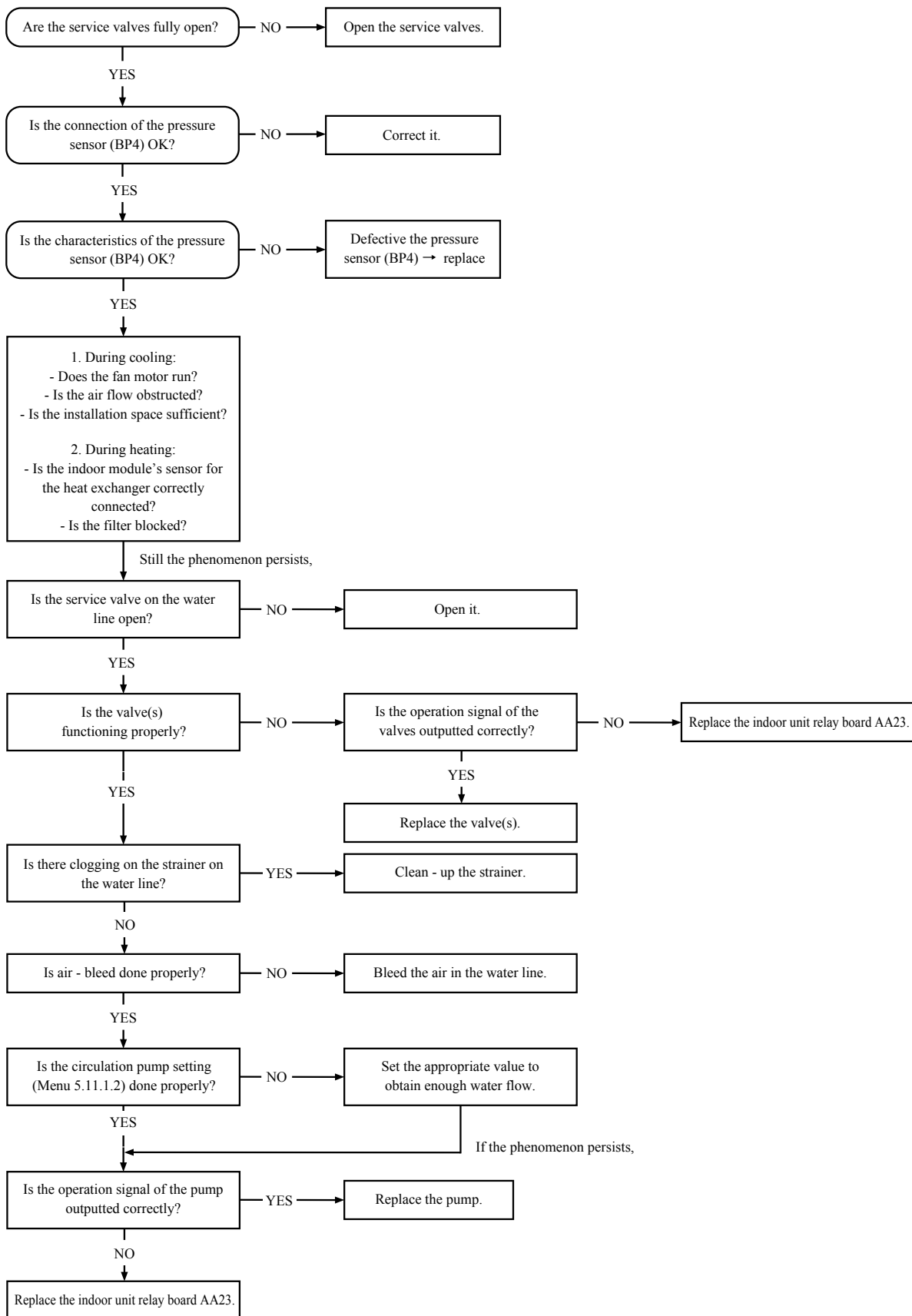

228 - Failed defrost operation

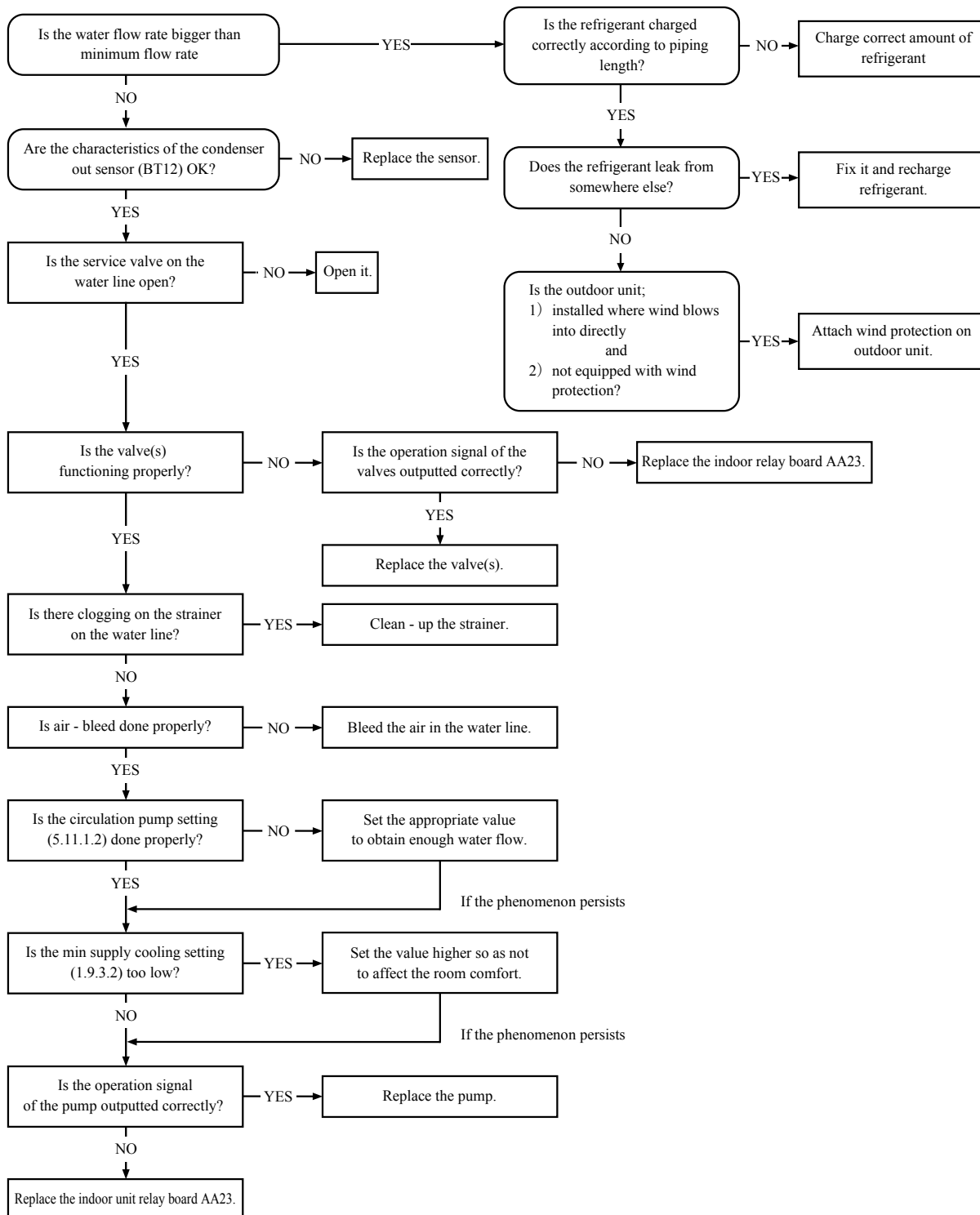

### 294 - Incompatible heat pump

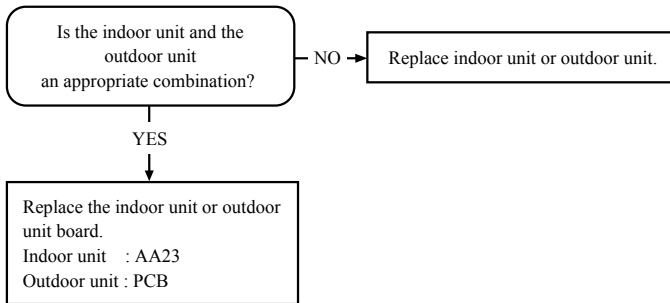

404 - S. fault HP

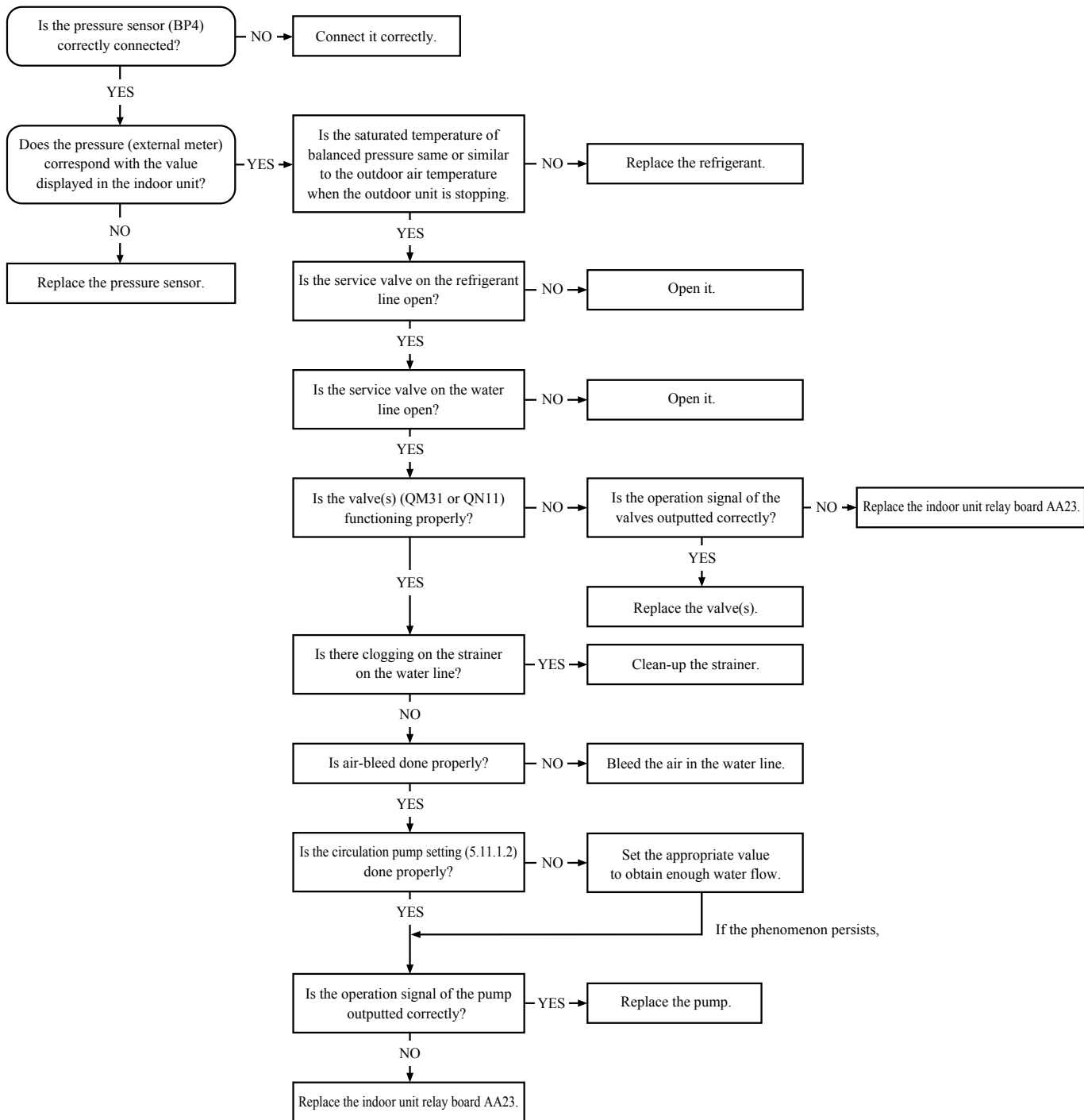

### 403, 412, 415, - Sensor fault from PCA154

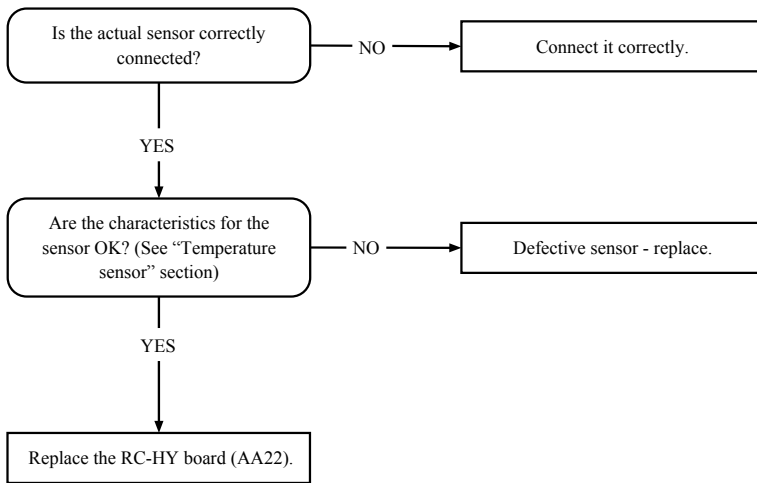



### E35 - High HX temp

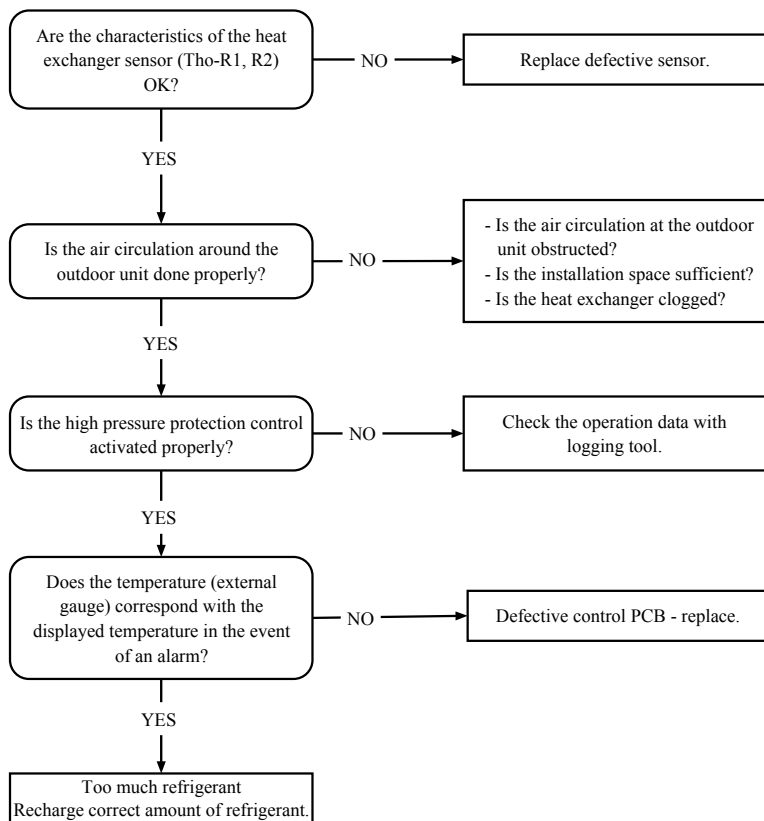

**E36 - Hot gas alarm**

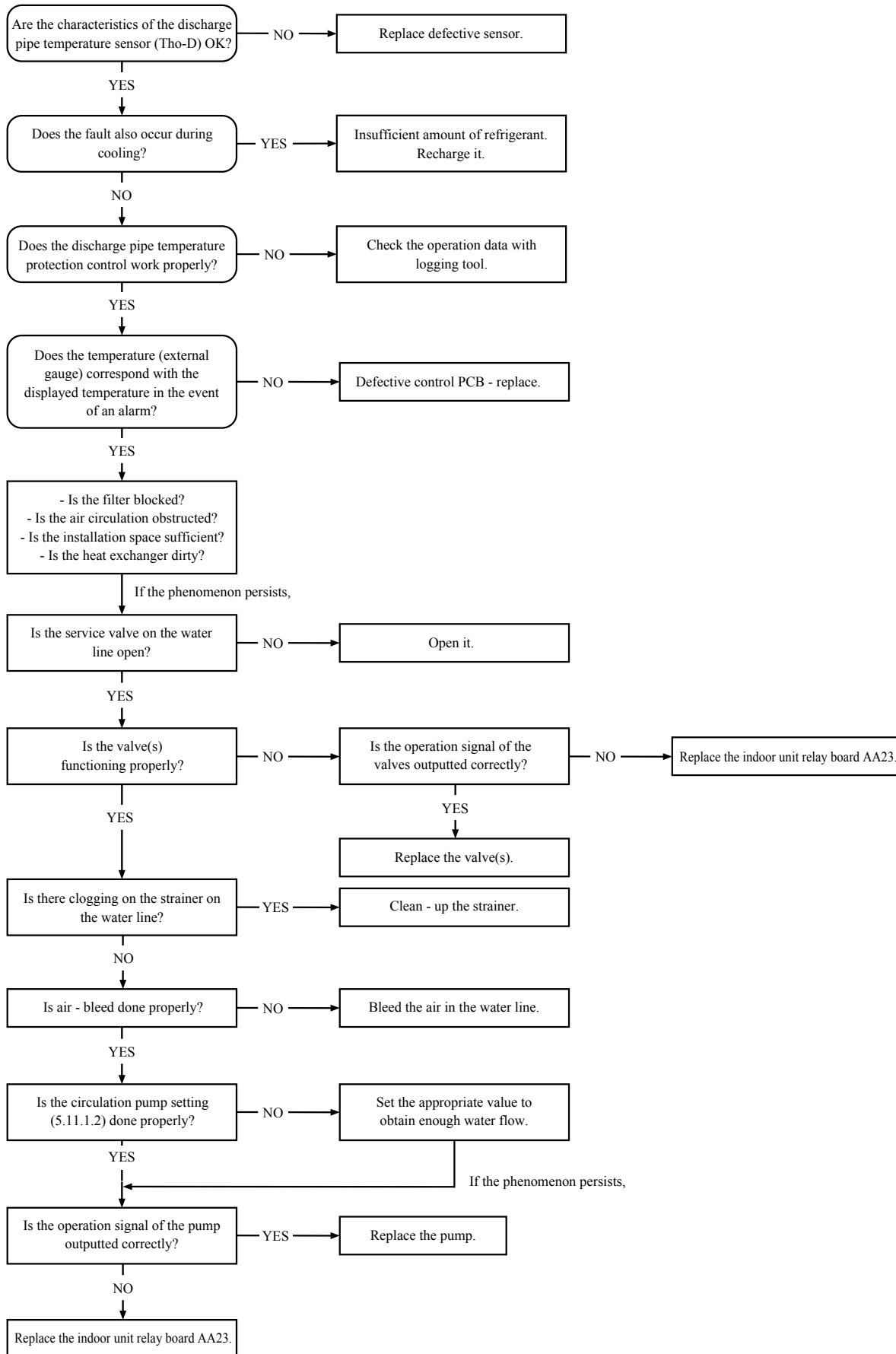

### E37 - S. fault Tho-R

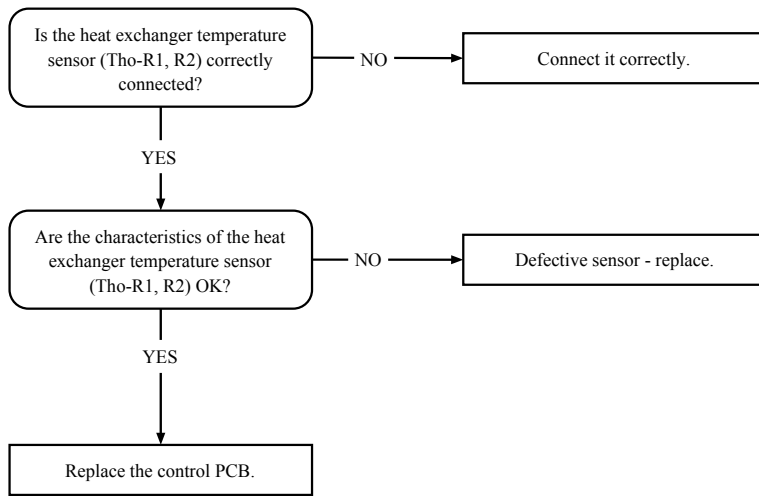

### E38 - S. fault Tho-A

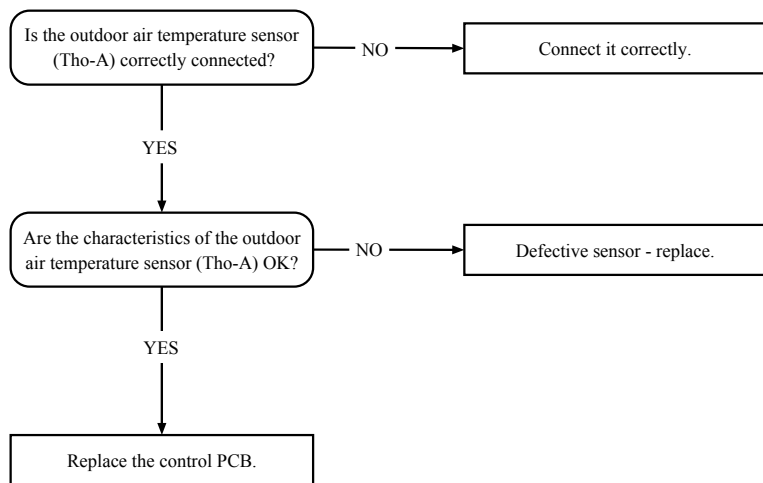

**E39 - S. fault Tho-D**

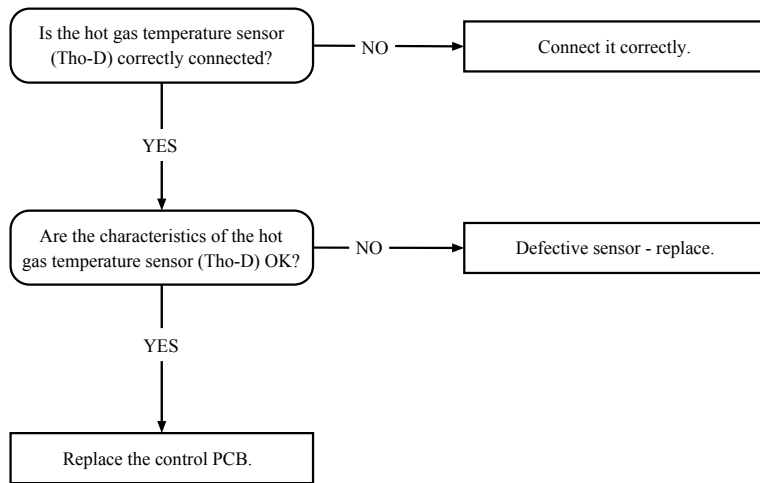

### E40 - High pressure alarm

If the power source voltage to the outdoor unit is switched off and on too quickly, E40 may be displayed. This is normal.

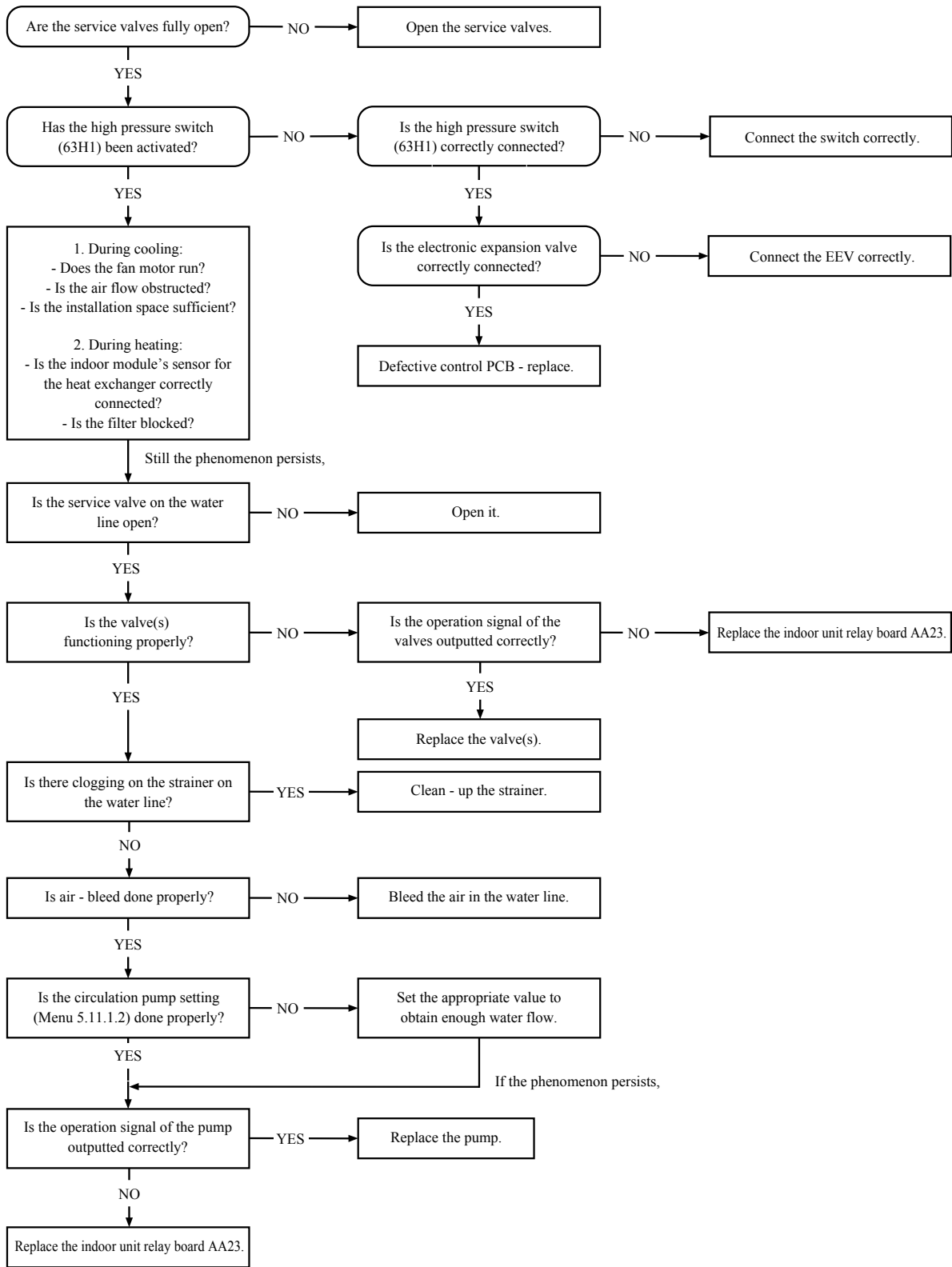

**E42 - Current cut**

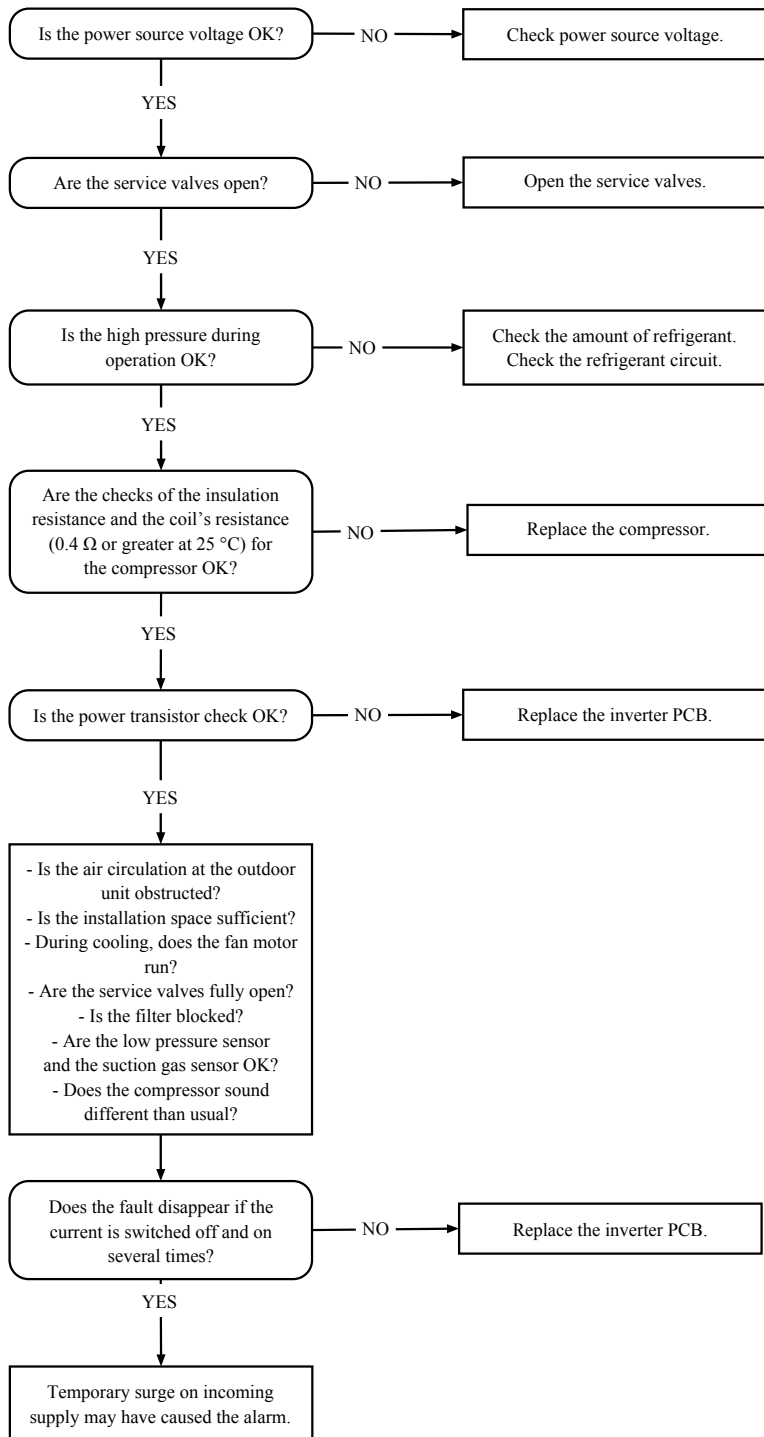

### E47 - Inverter A/F module over current

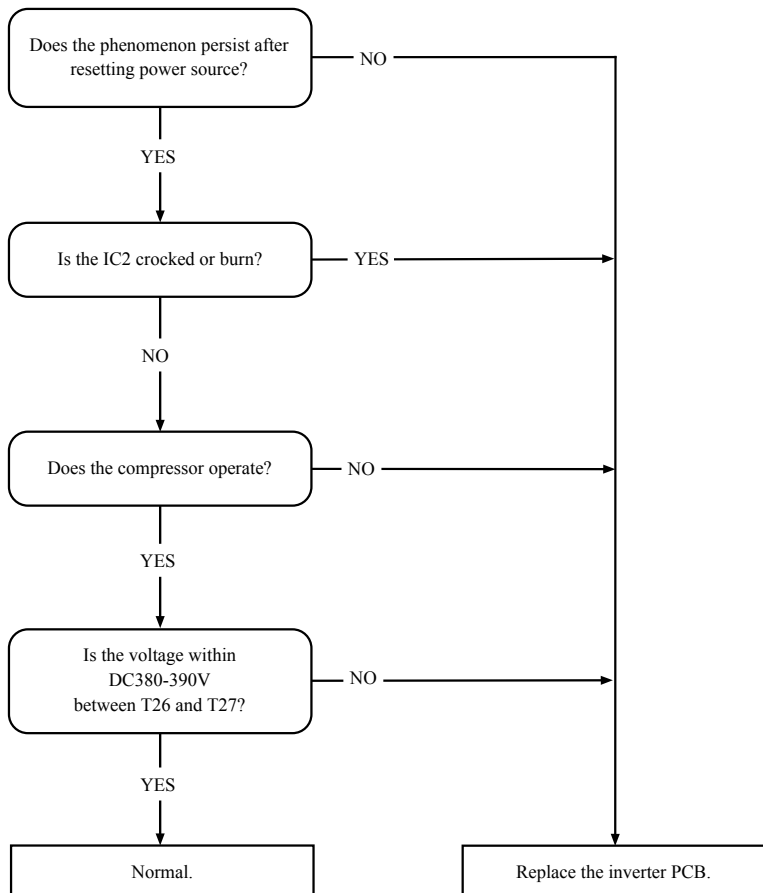



**E48 - Fan alarm**

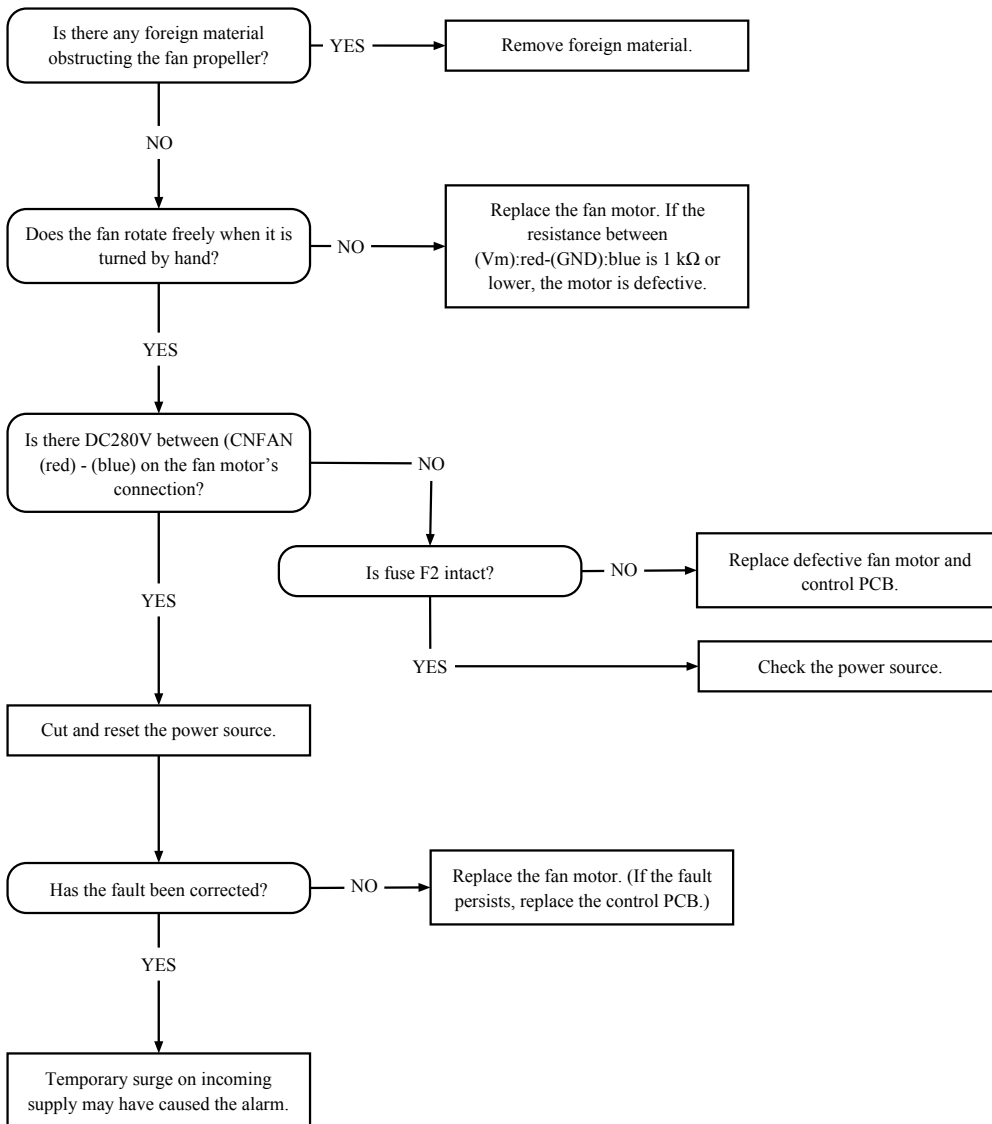

### E51 - Inverter and fan motor error

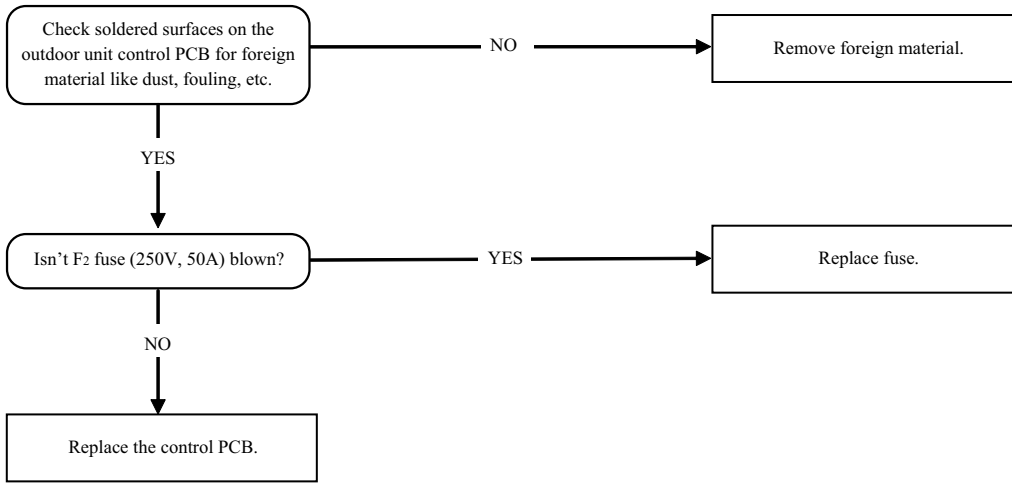

### E59 - Inverter error

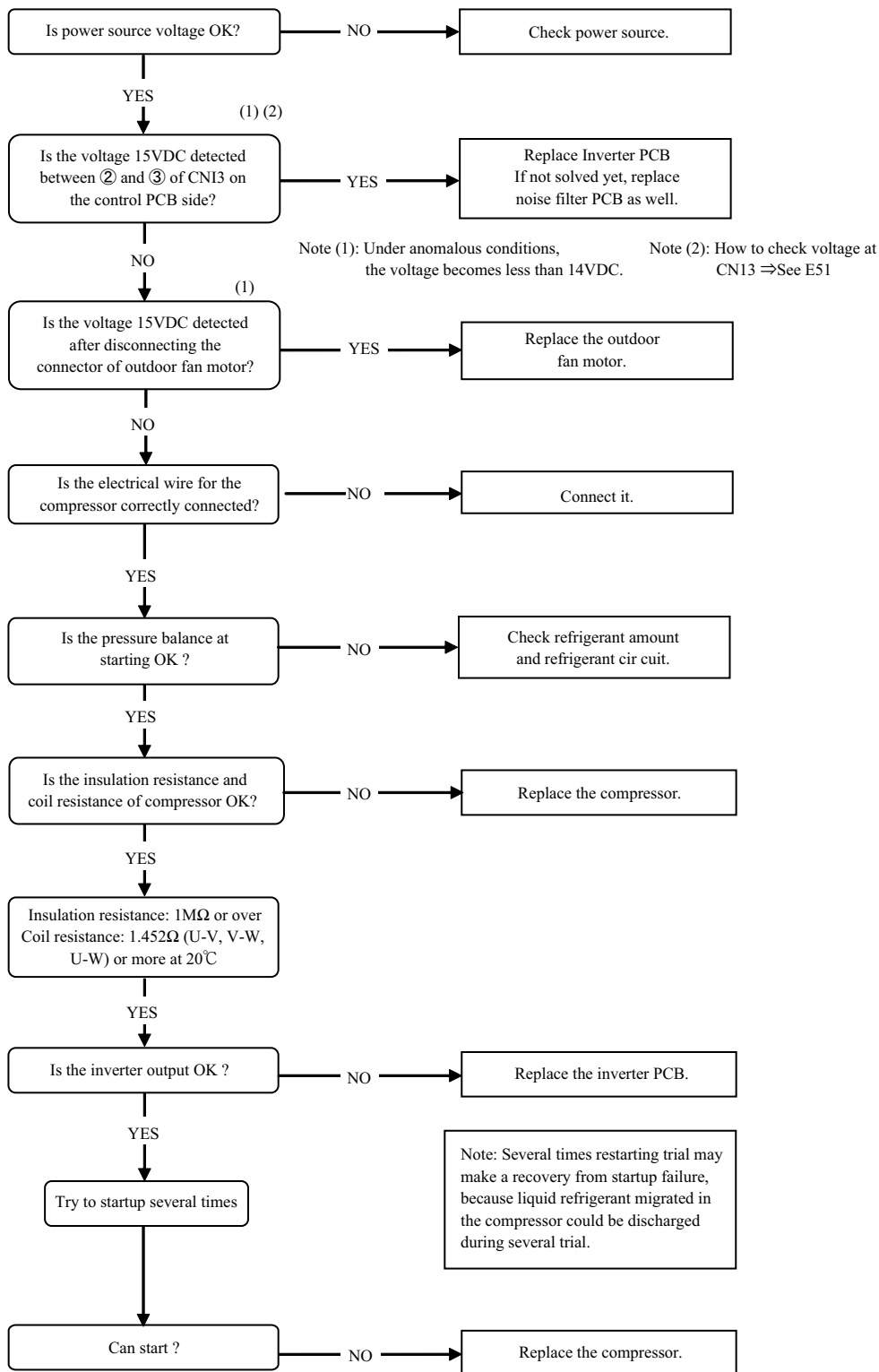

### E60 - Rotor lock

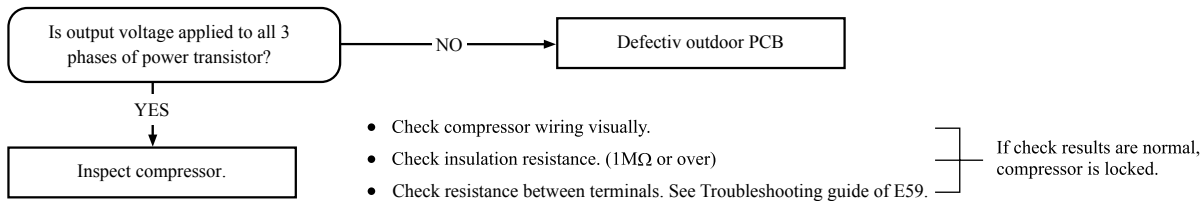

**Model FDCW60VN-X**

**◆ Check point of outdoor unit**

**⚠ CAUTION – HIGH VOLTAGE**  
 High voltage is produced in the control box. Don't touch electrical parts in the control box for 5 minutes after the unit is stopped.

**Color symbol**

Mark	Color
BK	Black
BL	Blue
RD	Red
WH	White
YE	Yellow
Y/G	Yellow/Green

**◆ Voltage check in PCB**

The normal range is as follows.

Display	Voltage range
① DC280V	DC230V – DC310V
② DC 20V	DC 18V – DC 22V
③ DC 13V	DC 12V – DC 14V
④ DC 15V	DC 14V – DC 16V
⑤ DC 5V	DC 4V – DC 6V
⑥ DC 2.5V	DC 2.3V – DC 2.5V

**◆ Inspection power transistor**

Remove the fasten terminal and test output voltage

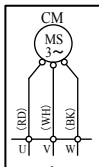

**◆ Power source and serial signal inspection**

- ① to ② : AC220/230/240V
- ① to ②/N : AC220/230/240V
- ②/N to ③ : Normal if the voltage oscillates between DC0 and approx. 20V

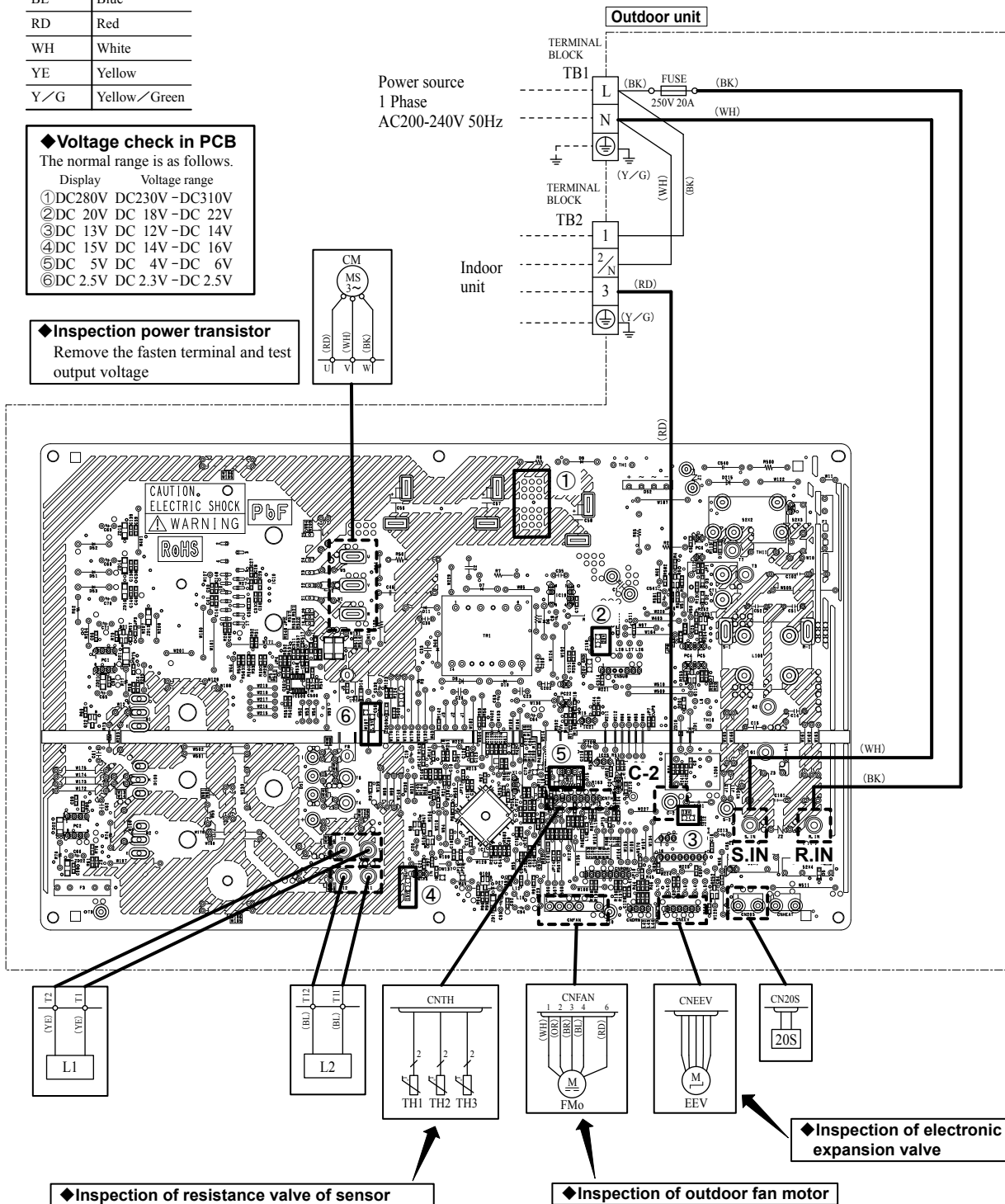

**◆ Inspection of resistance valve of sensor**

**◆ Inspection of outdoor fan motor**

**◆ Inspection of electronic expansion valve**

**(a) Inspection of electronic expansion valve**

Electronic expansion valve operates for approx. 10 seconds after the power on, in order to determine its aperture. Check the operating sound and voltage during the period of time. (Voltage cannot be checked during operation in which only the aperture change occurs.)

- (i) If it is heard the sound of operating electronic expansion valve, it is almost normal.
- (ii) If the operating sound is not heard, check the output voltage.

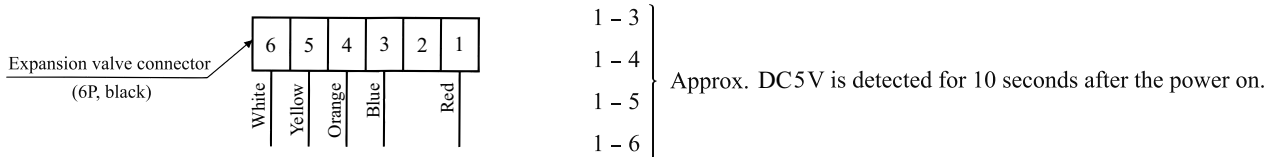

- (iii) If voltage is detected, the outdoor PCB is normal.
- (iv) If the expansion valve does not operate (no operating sound) while voltage is detected, the expansion valve is defective.

**• Inspection of electronic expansion valve as a separate unit**

Measure the resistance between terminals with an analog tester.

Measuring point	Resistance when normal
1-6	46 ± 4Ω (at 20°C)
1-5	
1-4	
1-3	

**(b) Outdoor unit fan motor check procedure**

- When the outdoor unit fan motor error is detected, diagnose which of the outdoor unit fan motor or outdoor PCB is defective.
- Diagnose this only after confirming that the indoor unit is normal.

**(i) Outdoor PCB output check**

- 1) Turn off the power.
- 2) Disconnect the outdoor unit fan motor connector CNFAN.
- 3) When the indoor unit is operated by inserting the power source plug and pressing (ON) the backup switch for more than 5 seconds, if the voltage of pin No. ② in the following figure is output for 30 seconds at 20 seconds after turning “ON” the backup switch, the outdoor PCB is normal but the fan motor is defective.

If the voltage is not detected, the outdoor PCB is defective but the fan motor is normal.

Note (1) The voltage is output 3 times repeatedly. If it is not detected, the indoor unit displays the error message.

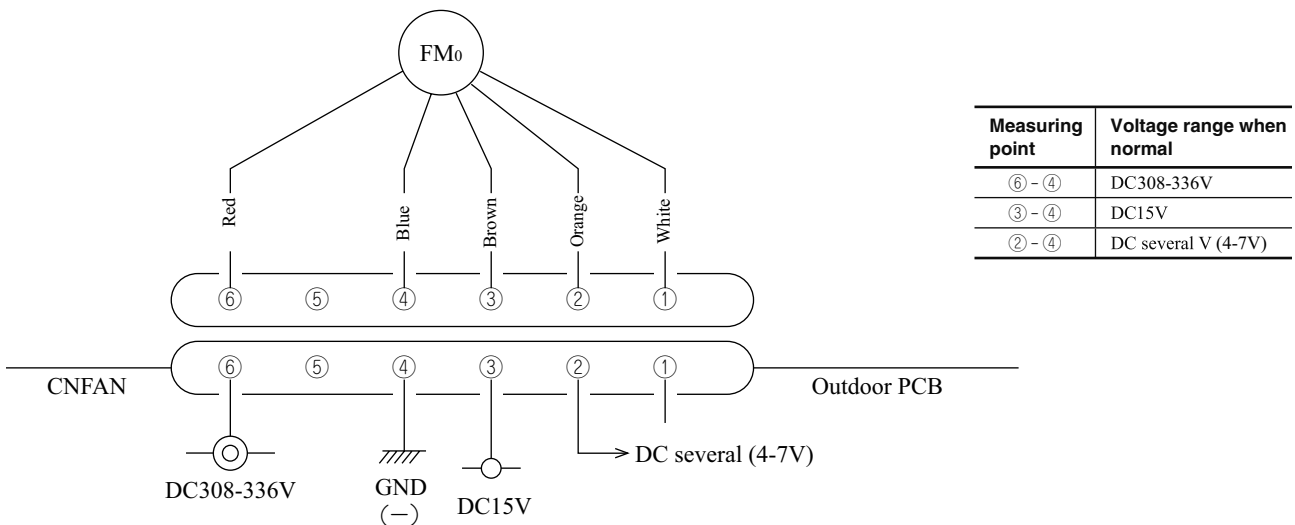

**(ii) Fan motor resistance check**

Measuring point	Resistance when normal
⑥ - ④ (Red - Blue)	20 MΩ or higher
③ - ④ (Brown - Blue)	20 kΩ or higher

- Notes (1) Remove the fan motor and measure it without power connected to it.
- (2) If the measured value is below the value when the motor is normal, it means that the fan motor is faulty.

**(c) Inspection of resistance valve of temperature sensor**

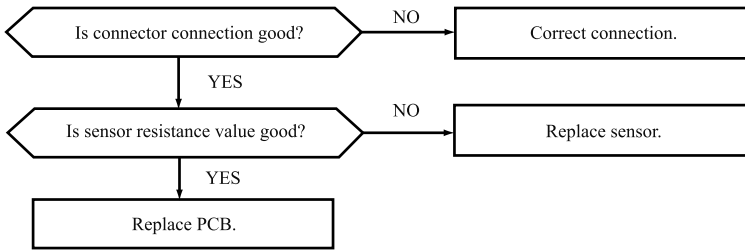

**◆ Discharge pipe temperature sensor characteristics**

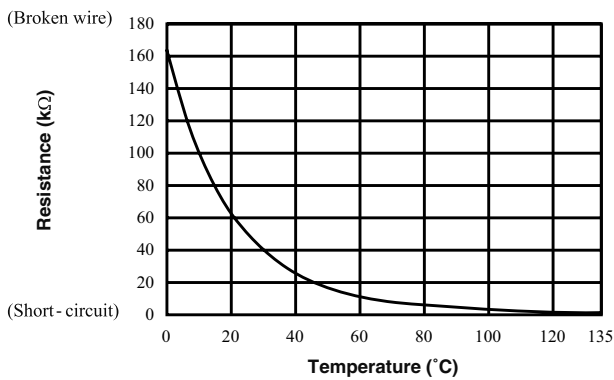

**◆ Temperature sensor characteristics [Outdoor heat exchanger temperature, outdoor air temperature]**

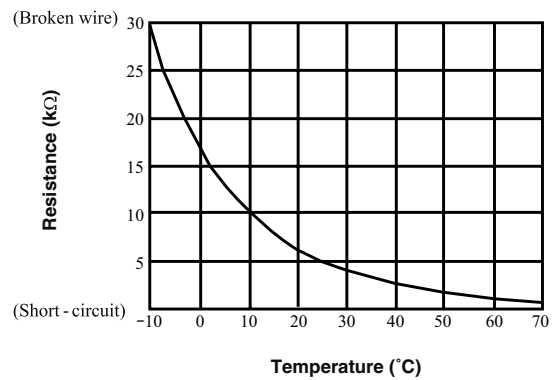

# Component replacement

## Indoor units

### HSB60-W

#### Open HSB unit

1. Remove 2 screws from the bottom part of the unit



Screws are located here (bottom)



Screws

2. Remove the lid by pulling it and pushing it up





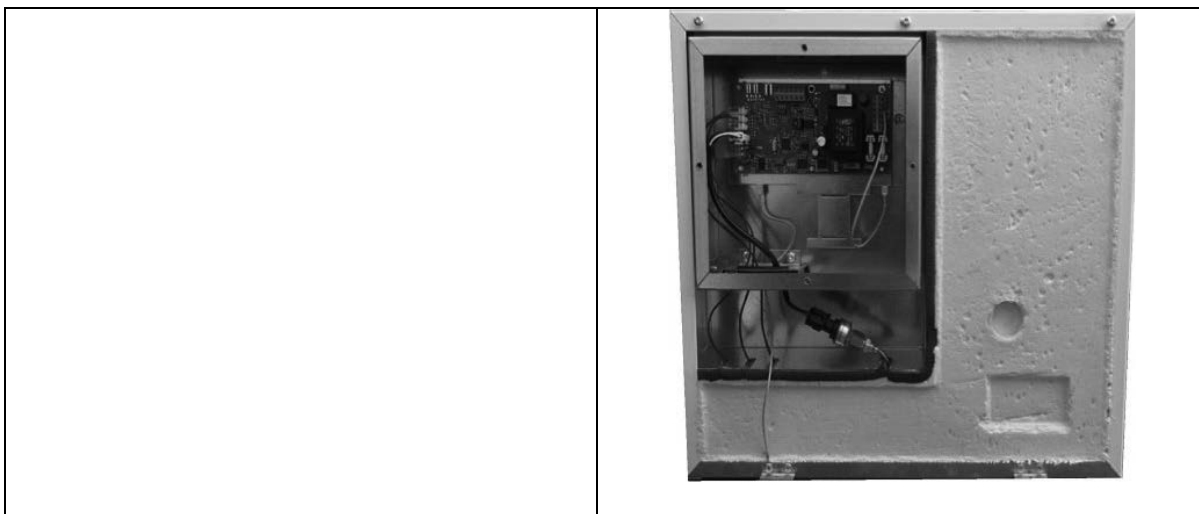

**Replace AA23 communication card**

1. Disconnect all wiring and remove AA23 card by unlocking plastic PCB holders



AA23 communication card

2. Place the new AA23 communication card, lock in on plastic holders, connect all cabling and close unit

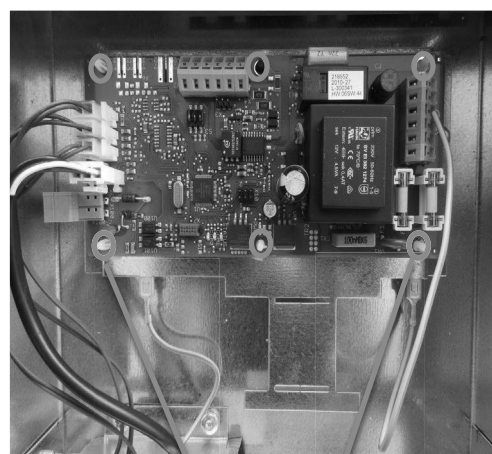

Plastic holders

**Replace pressure sensor BP4**

Before removing pressure the pressure sensor make sure that you pump down the unit and that outdoor unit valves are closed!

1. Unscrew BP4 pressure sensor, remove cabling from AA23 communication card.



BP4 connector      Pressure sensor (BP4)

2. Install the new pressure sensor, connect all the cables, pressure test the circuit for leak check and then open the outdoor unit valves.

**Replace temperature sensor BT15**

1. Cut the insulation material in the square box that is on the bottom right part of the HSB unit.



BT15 connector      Insulation  
BT15 is in the back.

2. Remove the damaged sensor and its cabling.

3. Install the new sensor and guide the sensor cable to AA23 communication card.

**Replace temperature sensor BT12 and BT3**

As temperature sensors BT12 (heating medium flow) and BT3 (heating medium return) are installed on the water pipes (back of the unit) and covered with insulation there is limitation to access, so it is not possible to remove damaged sensors. Solution is leave the sensors on the unit and install the new ones in a different position.

1. Install the new sensor (BT12 or BT3) on the external water pipes from the unit. Make sure that there is contact between the sensor and the pipe and that the sensor is insulated a long the pipe.



BT12

BT3

2. Guide the new sensor cable to AA23 communication board using one of the available cable glands



Cable glands

3. Remove cabling from the damaged temperature sensor and connect the new one.



BT12/BT3 connector

**PT300**

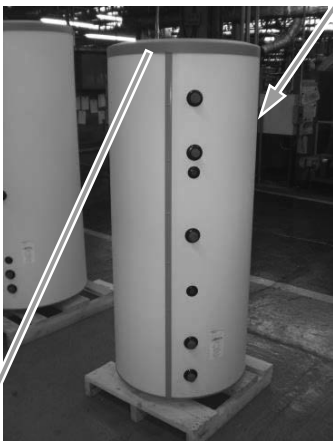
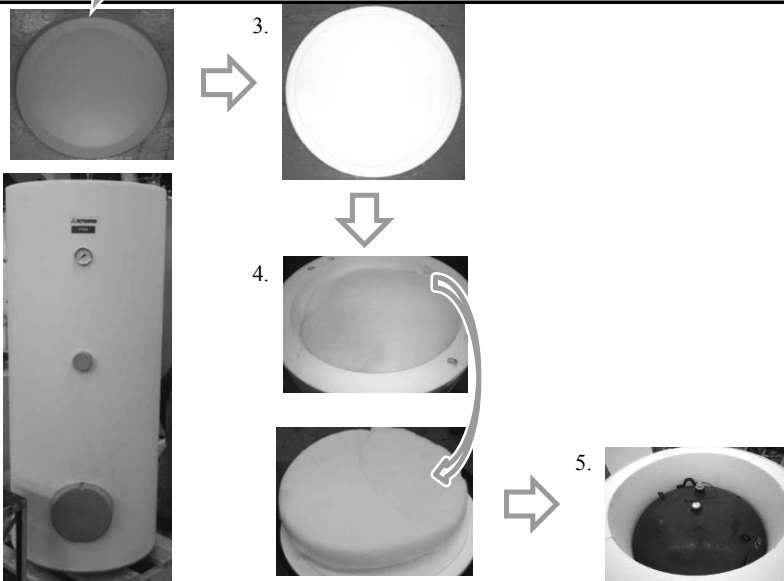
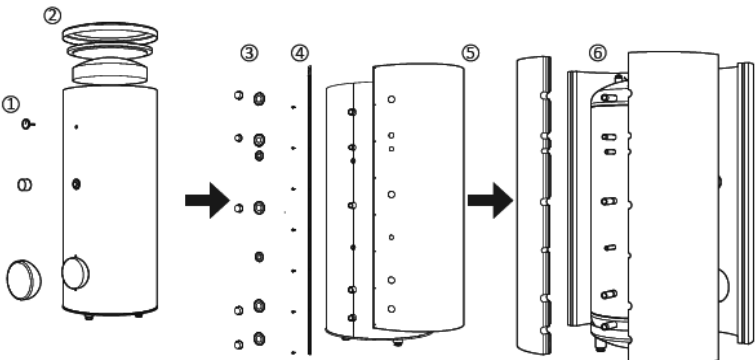
Tank of PT300	
<p><b>1.</b> Remove the top panel of the tank.</p>	
<p><b>2.</b> Remove the styrofoam. <b>3.</b> See the tank.</p>	
<p><b>4.</b> (Details)</p> <p>(1) Remove the temperature gauge, plug of the heating element connector pipe and blanking plate of the inspection opening.</p> <p>(2) Remove the upper cover of the housing together with thermal insulation.</p> <p>(3) Remove the plugs from the connector pipes and black bushings.</p> <p>(4) Remove the fixing screws and the strip connecting the housing jacket.</p> <p>(5) Remove the jacket surrounding the tank (housing jacket.)</p> <p>(6) Remove the four-piece thermal insulation.</p>	

RC-HY20/40-W

**Controller**

- 1. Loosen the screw and remove the lid and control box first.
- 2. Loosen 2 screws and remove the lid of control box.

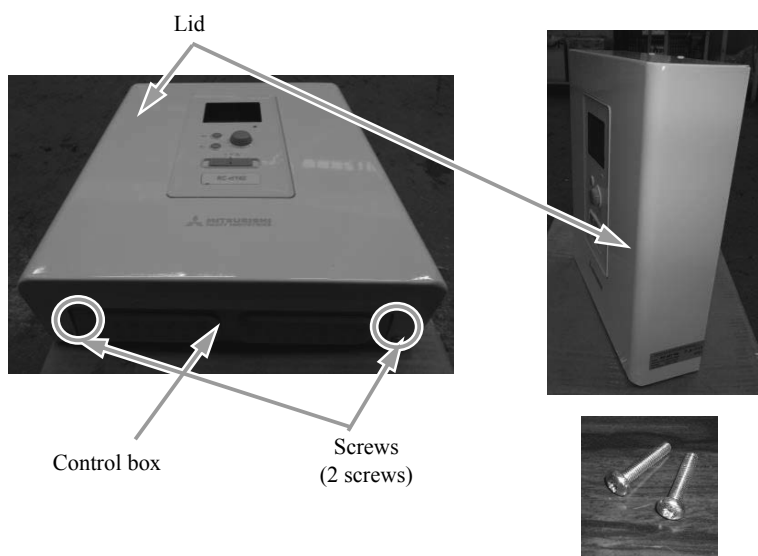

- 3. Remove the bracket of the lid from hole of the control box.

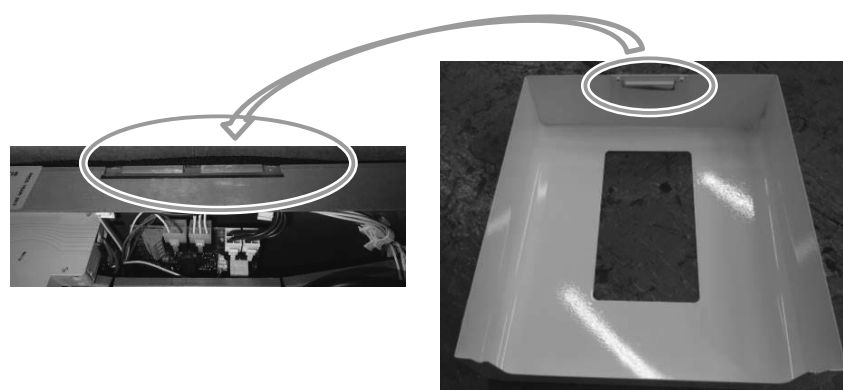

- 4. Remove the lid.
- 5. Check the inside of the control box.

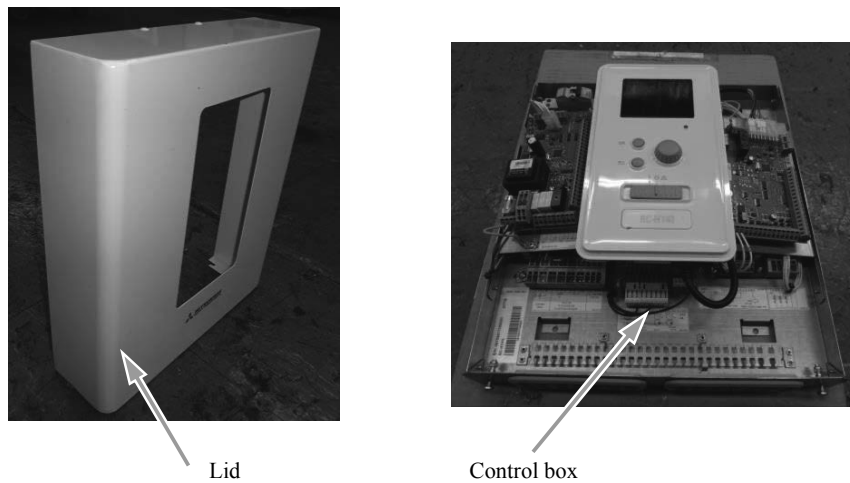

**Outdoor unit**  
**FDCW60VNX-W**

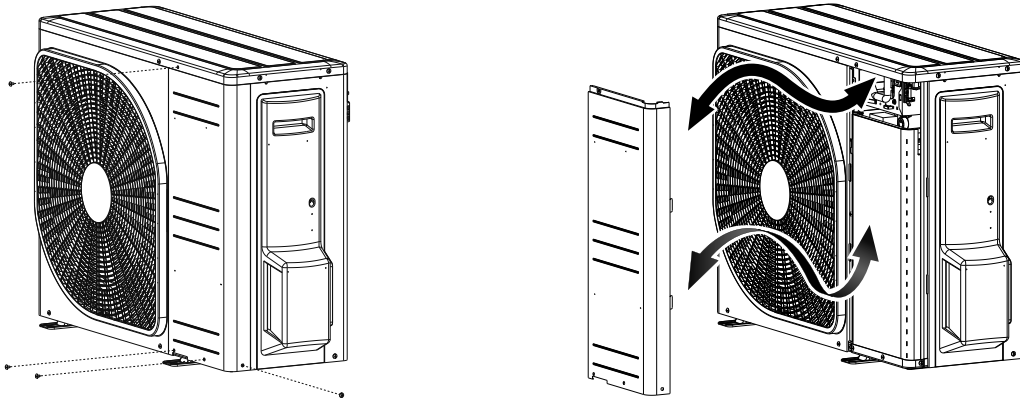

**FDCW60VNX-W**

**Fan and fan motor (FMo1)**

- 1. Loosen the screw and remove the top panel and service panel first.
- 2. Loosen 7 screws and remove the panel including fan grills.

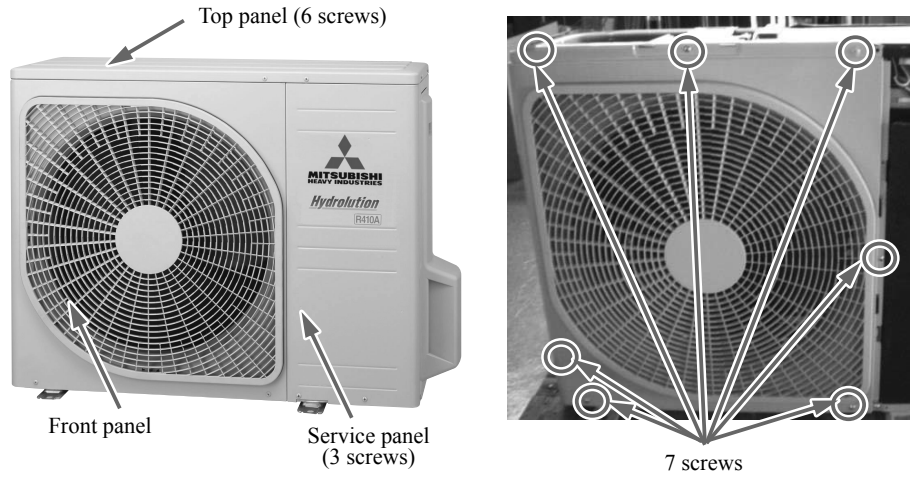

- 3. Loosen the nut and remove the fan propeller.

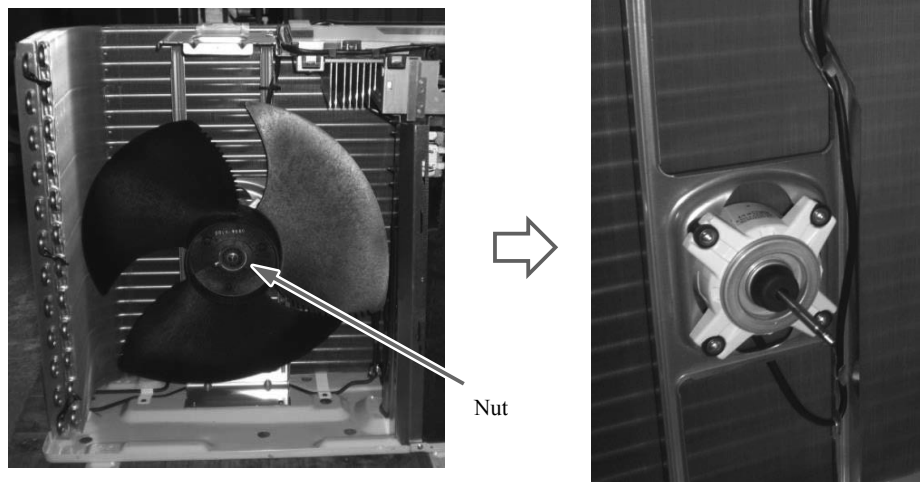

- 4. Disconnect the connector of CNFAN.

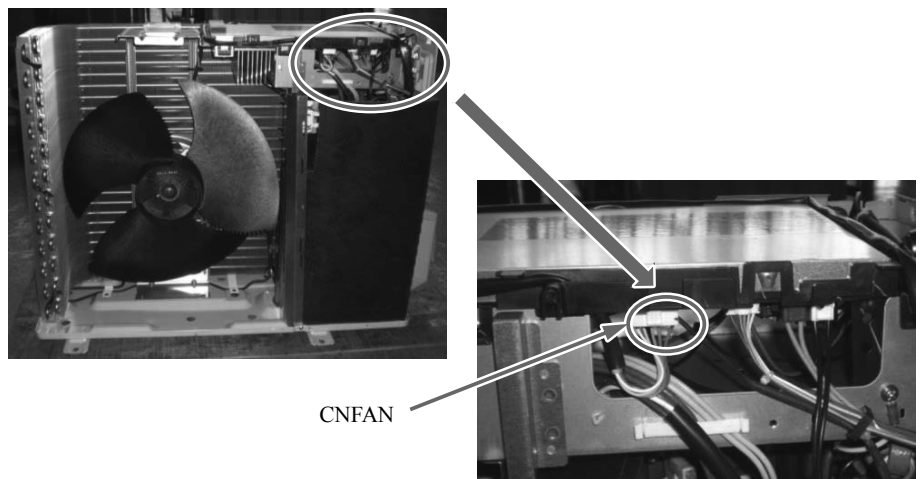

**Fan and fan motor (FMo1)**

5. Remove band and fan cable.

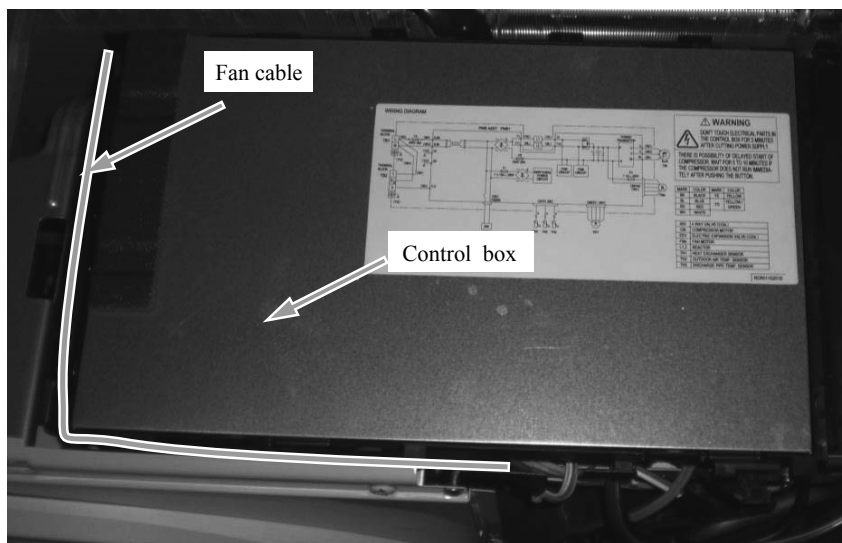

6. Release 2 metal clamps.

7. Loosen 4 screws and remove fan motor.

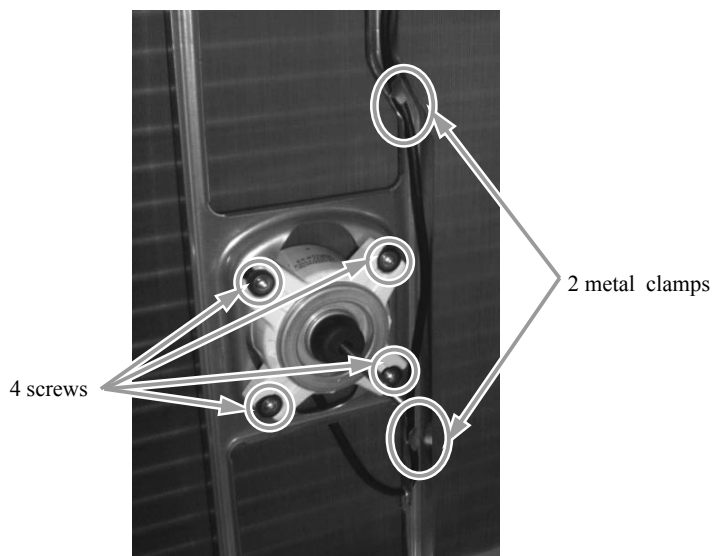

**Compressor (CM)**

1. Unit the strings and remove the outer insulation.

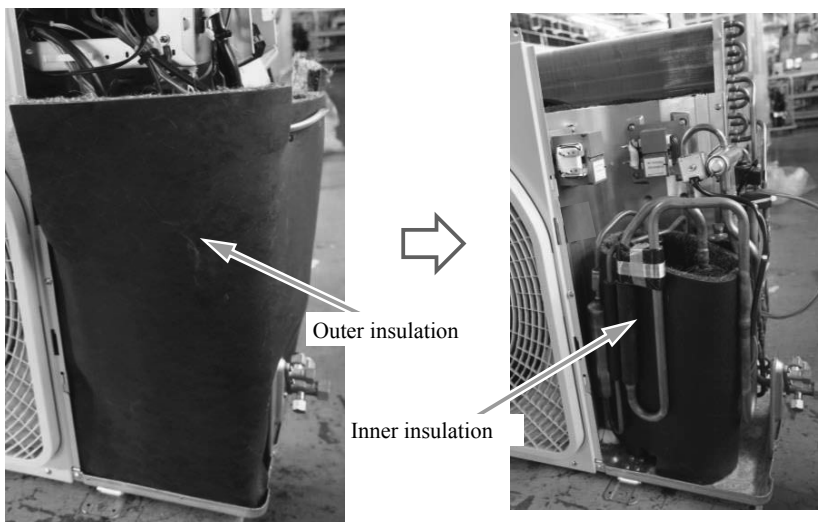



**Compressor (CM)**

- 2. Remove the top and inner insulations.
- 3. Take off sprig leaf and pull out sensor (Tho-D).

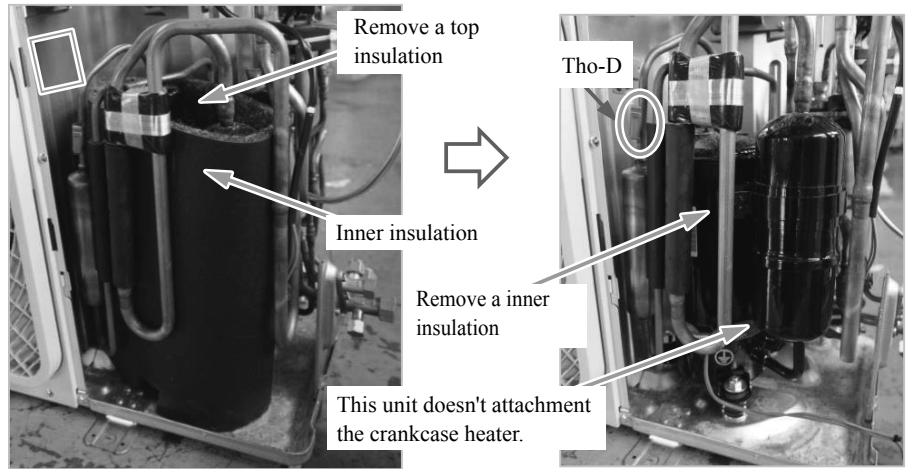

- 4. Remove the terminal cover.
  - 5. Disconnect the faston terminal connectors from compressor.
- U : Red cable  
 V : White cable  
 W : Blue cable

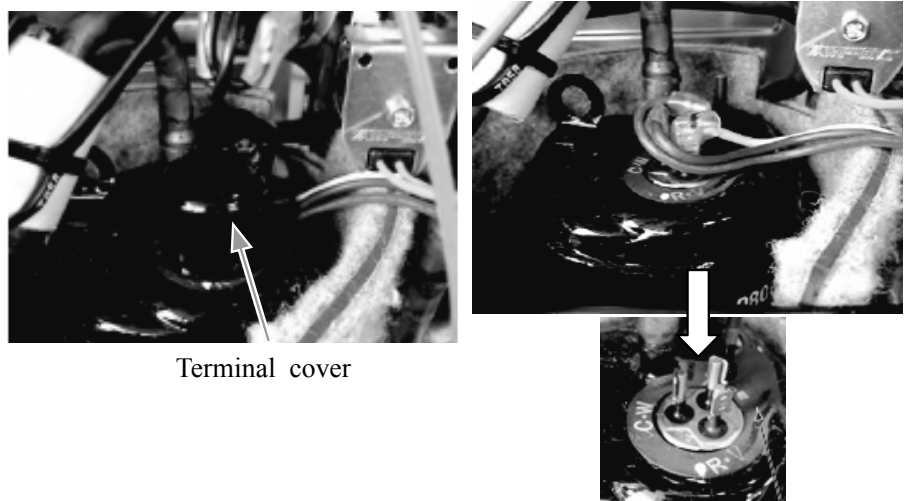

- 6. Loosen 3 units of compressor fixing bolts.

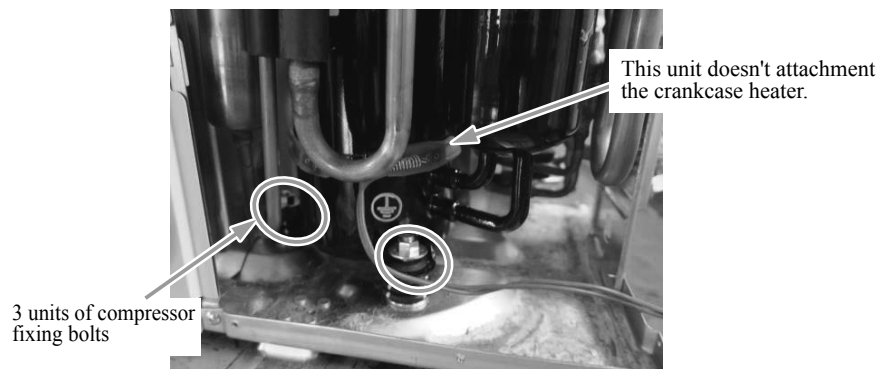

**Compressor (CM)**

7. Disconnect the pipes for suction and discharge.

8. Remove the compressor.

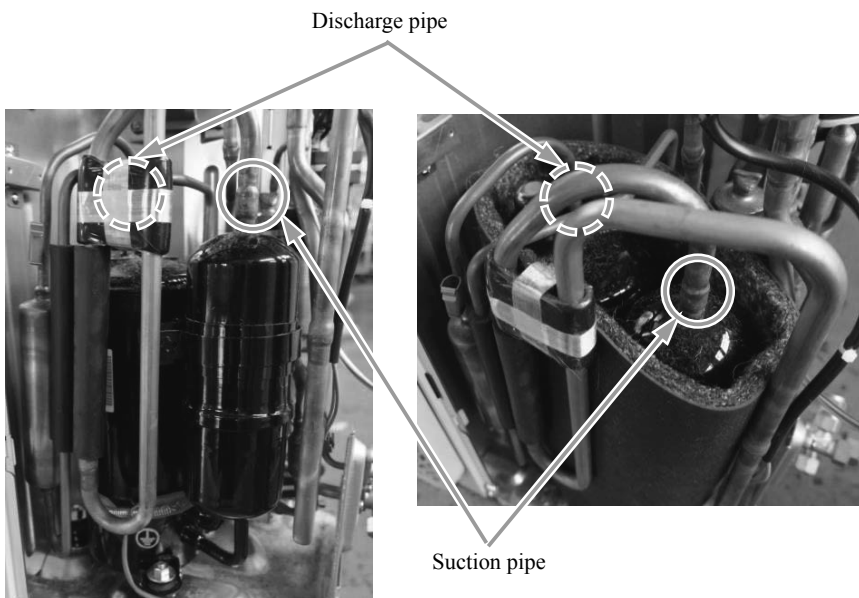

**Control PCB(PWB)**

1. Open the top panel.

2. Open the control box cover.

Note: Be sure to do this work after elapsing 3 minutes from OFF.

3. Loosen 4 screws.

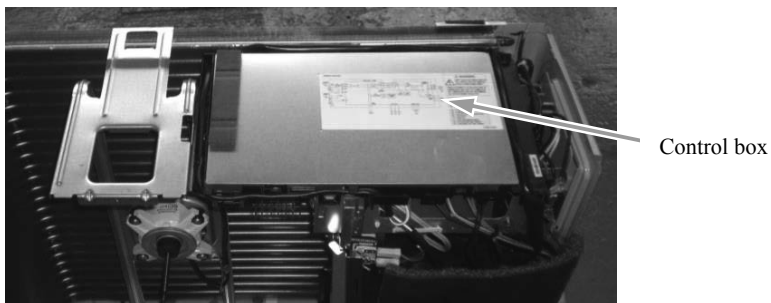

Open the control box cover.

Control PCB

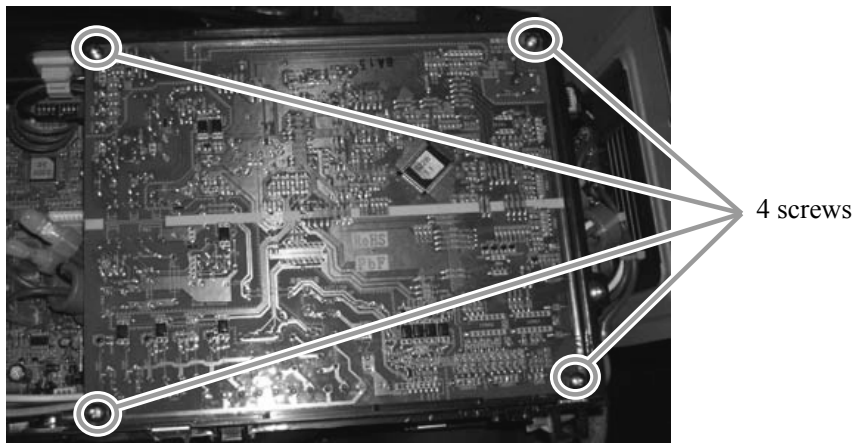

**Control PCB (PWB)**

**1. Disconnect all connectors and remove the control PCB.**

- (Connector)  
 CNHEAT  
 CN20S  
 CNEEV  
 CNROM  
 CNFAN  
 CNTH  
 L1  
 L2

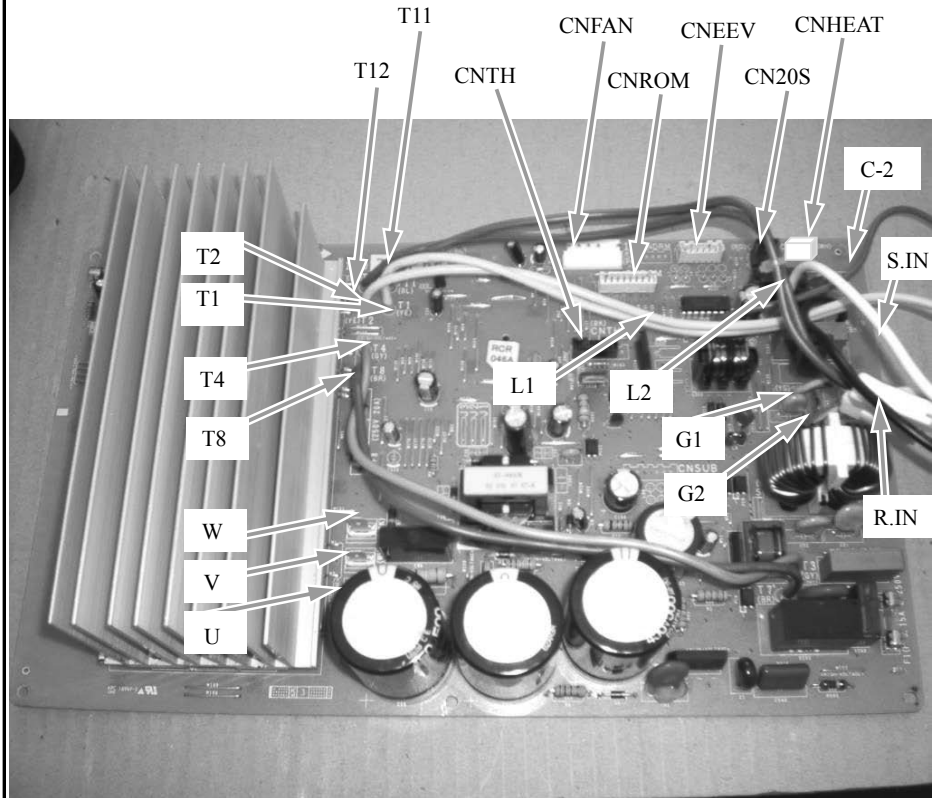

**2. Disconnect all terminals on the terminal block.**

- (Terminal block)  
 C-2(Harness color:RED)  
 S.IN(Harness color:WHITE)  
 R.IN(Harness color:BLACK)  
 G1 (Harness color:YELLOW/GREEN)  
 G2 (Harness color:YELLOW/GREEN)

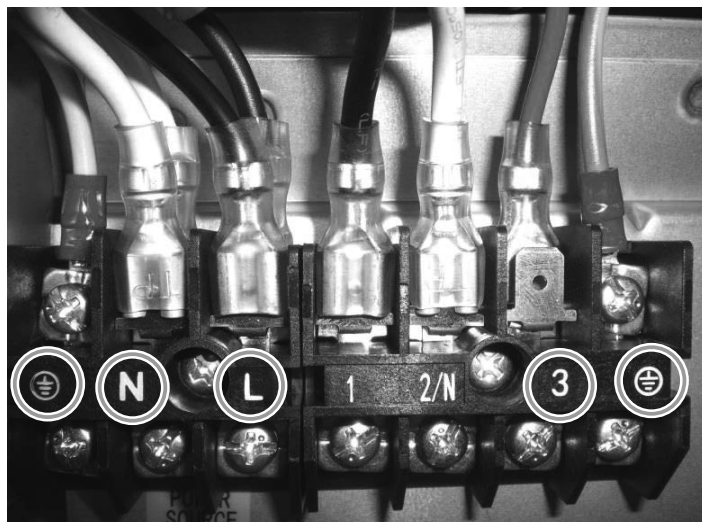

# Components

## Outdoor unit

### Compressor

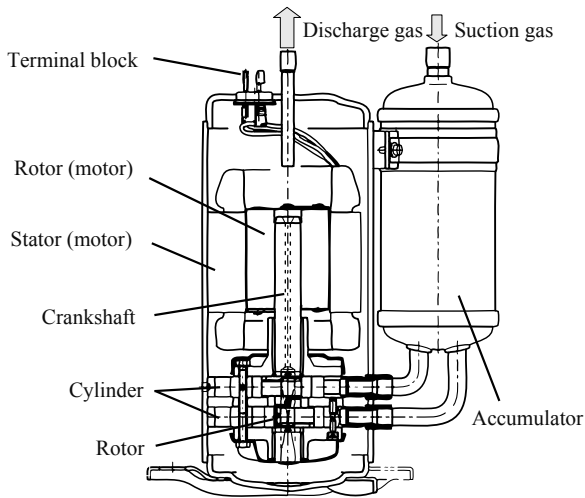

### Expansion valve

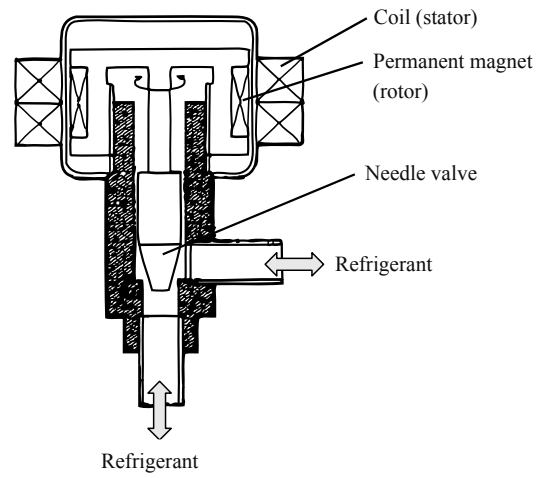

### 4-way valve

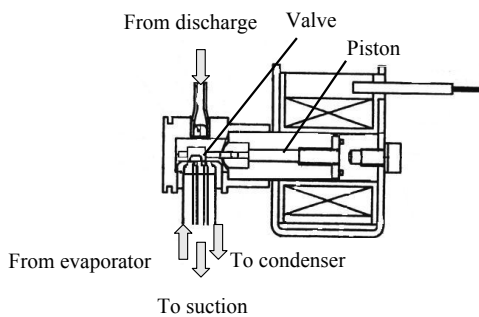
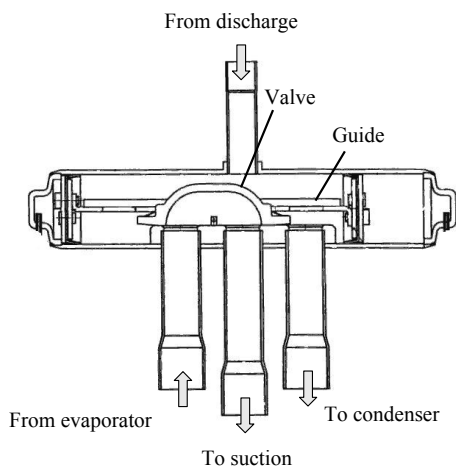

**HSB60-W**

Installation with indoor unit HSB60-W, tank PT300, controller RC-HY20/40-W with step controlled additional heat before reversing valve for hot water and cooling function (4-pipe system)

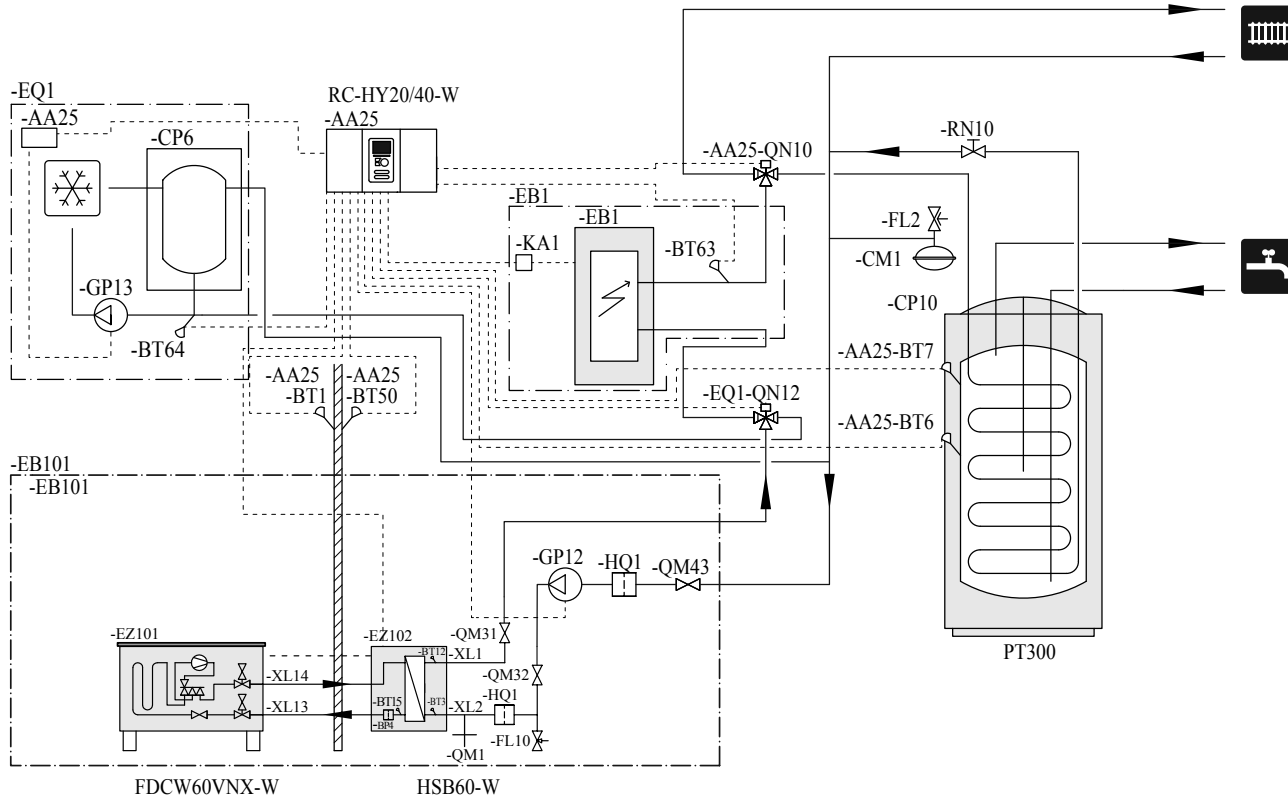

**Explanation**

**AA25 Controller**

- BT1 Outdoor sensor<sup>1)</sup>
- BT6 Temperature sensor, hotwater charging<sup>1)</sup>
- BT7 Temperature sensor, hot water top<sup>1)</sup>
- BT25 Temperature sensor, external supply line<sup>1)</sup>
- BT63 Temperature sensor, external supply line after electric heater
- BT71 Temperature sensor, external return line<sup>1)</sup>
- Tho-A Temperature sensor, Outdoor air
- Tho-D Temperature sensor, hot gas
- Tho-R Temperature sensor, heat exchanger out

# Temperature sensor

## Data for sensor in outdoor unit

Tho-D

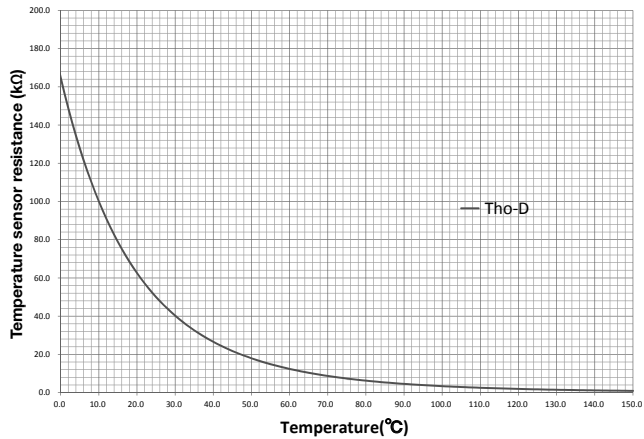

Tho-R

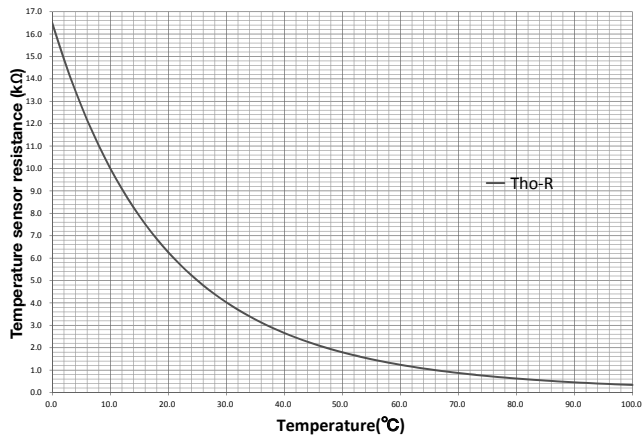

Tho-A

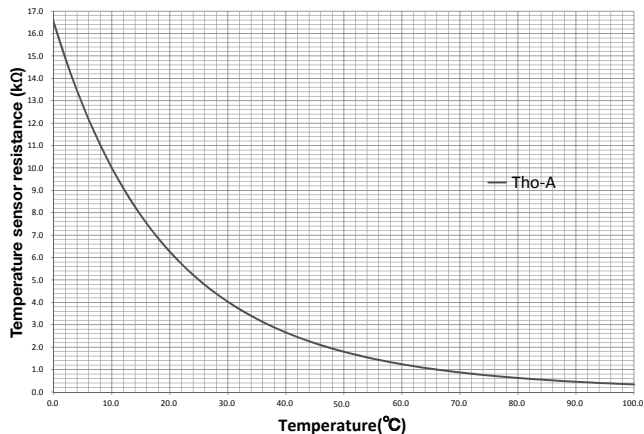

Temperature (°C)	Resistance (kΩ)	Voltage (VDC)
-40	351.0	3.256
-35	251.6	3.240
-30	182.5	3.218
-25	133.8	3.189
-20	99.22	3.150
-15	74.32	3.105
-10	56.20	3.047
-5	42.89	2.976
0	33.02	2.889
5	25.61	2.789
10	20.02	2.673
15	15.77	2.541
20	12.51	2.399
25	10.00	2.245
30	8.045	2.083
35	6.514	1.916
40	5.306	1.752
45	4.348	1.587
50	3.583	1.426
55	2.968	1.278
60	2.467	1.136
65	2.068	1.007
70	1.739	0.891
75	1.469	0.785
80	1.246	0.691
85	1.061	0.607
90	0.908	0.533
95	0.779	0.469
100	0.672	0.414

## Component positions

### Indoor units

#### Over view and design

#### HSB60-W

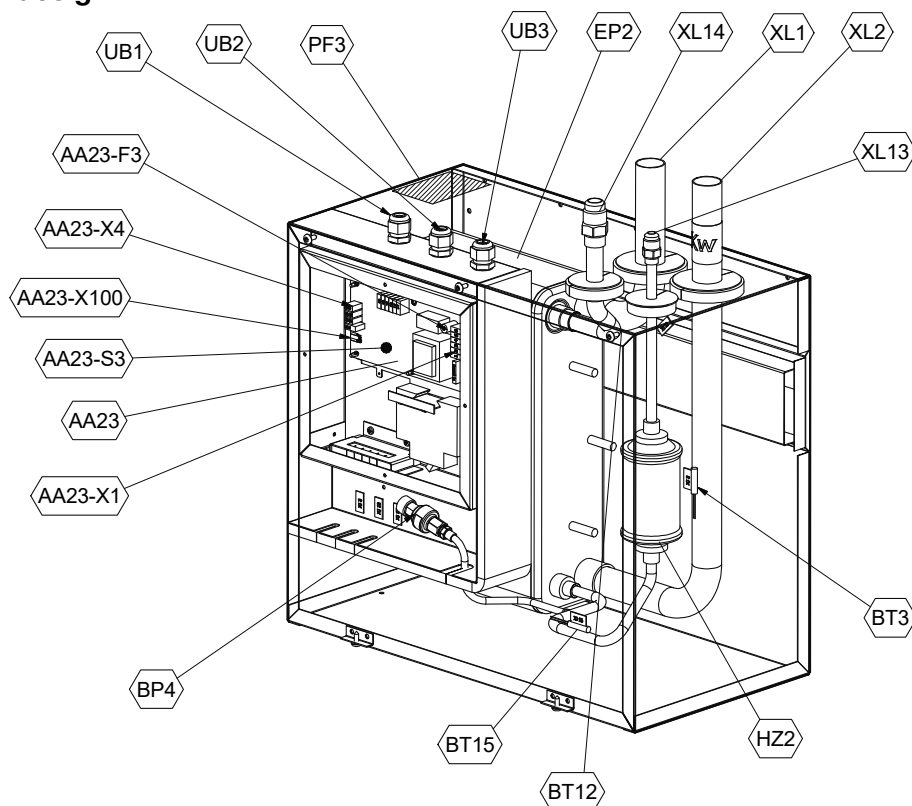

Symbol	Pipe connection
XL1 (Red mark)	Climate system supply $\phi 22$ mm
XL2 (Blue mark)	Climate system return $\phi 22$ mm
XL53	Refrigerant connection, liquid line, $\frac{1}{4}$ "
XL52	Refrigerant connection, gas line, $\frac{1}{2}$ "

Symbol	Sensor, thermostats
BP4	Pressure sensor, high pressure
BT3	Temperature sensor, heating medium, return
BT12	Temperature sensor, condenser, supply
BT15	Temperature sensor, fluid pipe

Symbol	Valves etc.
EP2	Heat exchanger
HQ1	Particle filter (supplied)
HZ2	Drying filter

Symbol	Miscellaneous
UB1	Cable gland
UB2	Cable gland
UB3	Cable gland

Symbol	Electrical components
AA23	Communication board
AA23-F3	Fuse for external heating cable
AA23-S3	DIP switch, addressing of outdoor unit
AA23-X1	Terminal block, incoming supply, connection of KVR
AA23-X4	Terminal block, communication with indoor module / control module
AA23-X100	Terminal block, communication outdoor module
X1	Terminal block, incoming component



HSB60-W

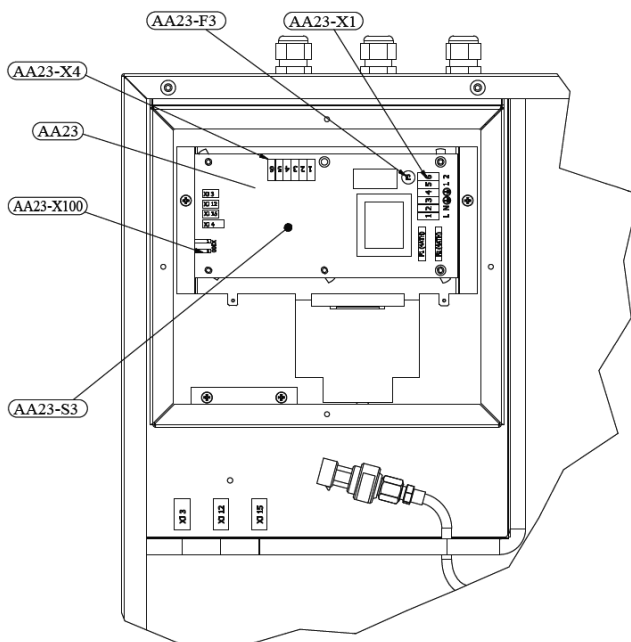

**Explanation**

- AA23            Communication board
- AA23-F3       Fuse for external heating cable
- AA23-S3       DIP switch, addressing of outdoor unit
- AA23-X1       Terminal block, incoming supply, connection of KVR
- AA23-X4       Terminal block, communication with indoor module / control module
- AA23-X100    Terminal block, communication outdoor module FDCW

PT300

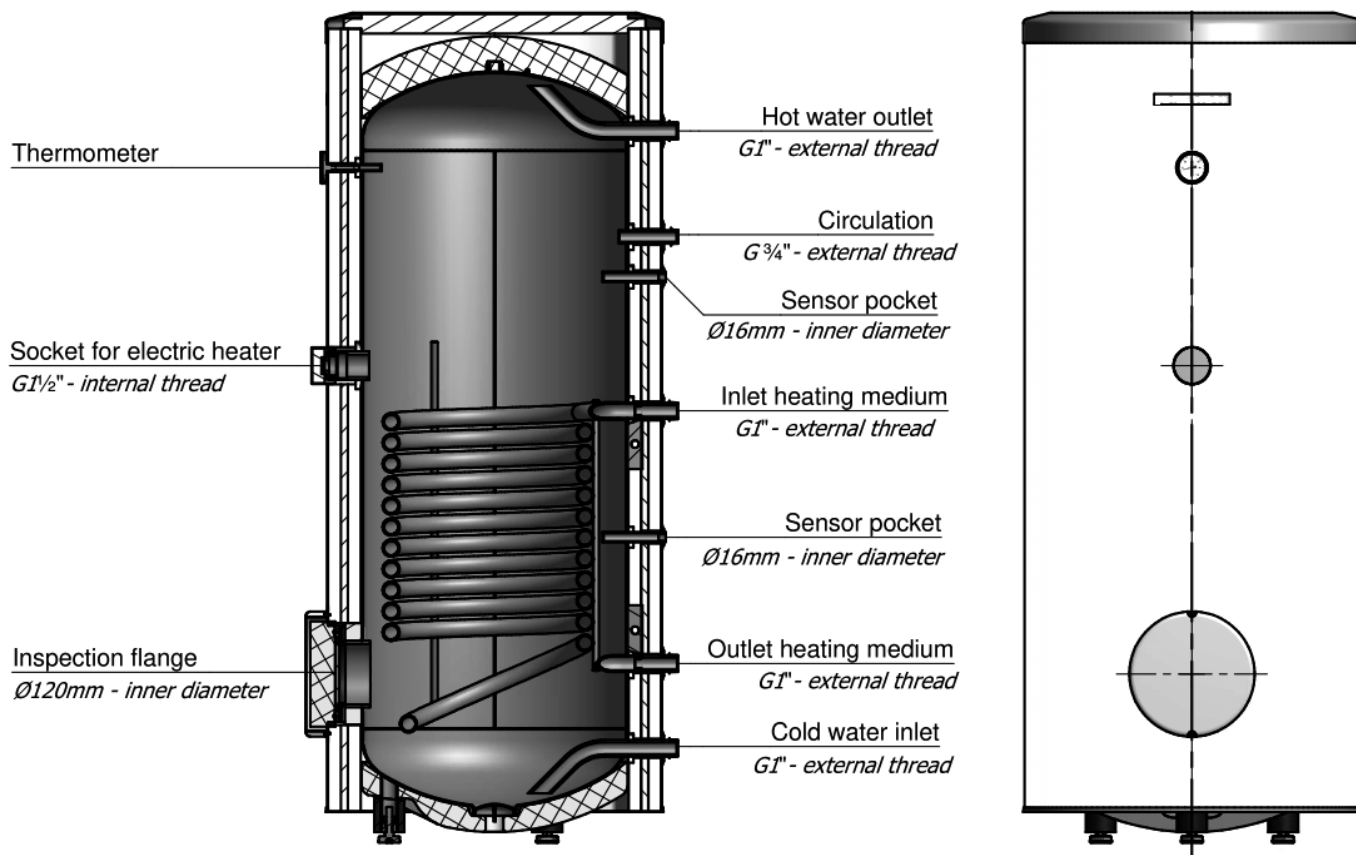

PT300

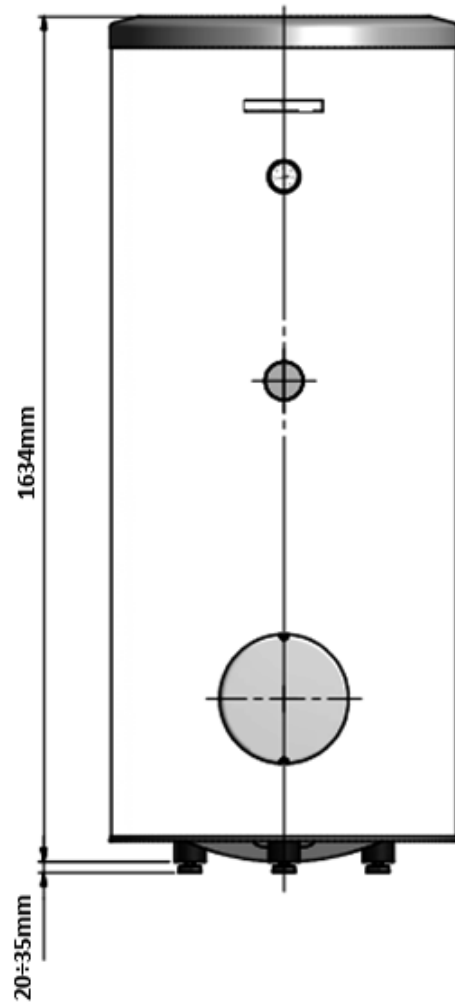

	PT300
A(mm)	1634
B(mm)	743
ØC(mm)	673

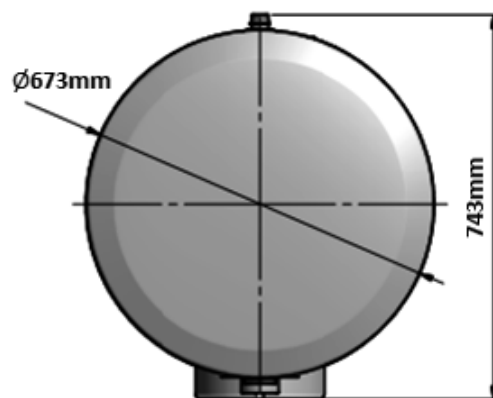

RC-HY20-W

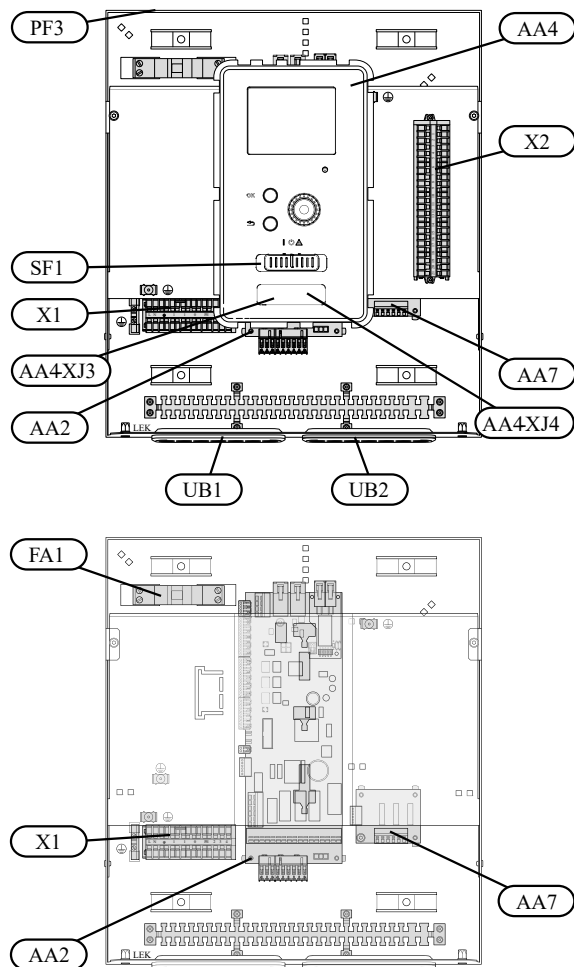

**Explanation**

- AA2 Base card
- AA4 Display unit
- AA4-XJ3 USB socket
- AA4-XJ4 Service outlet (No function)
- AA7 Extra relay circuit board
- FA1 Miniature circuit-breaker
- X1 Terminal block, incoming electrical supply
- X2 Terminal block, control signal circulation pump, sensors AUX inputs and heat pump
- SF1 Switch
- PF3 Serial number plate
- UB1 Cable grommet, incoming supply electricity, power for accessories
- UB2 Cable grommet, signal

**RC-HY40-W**

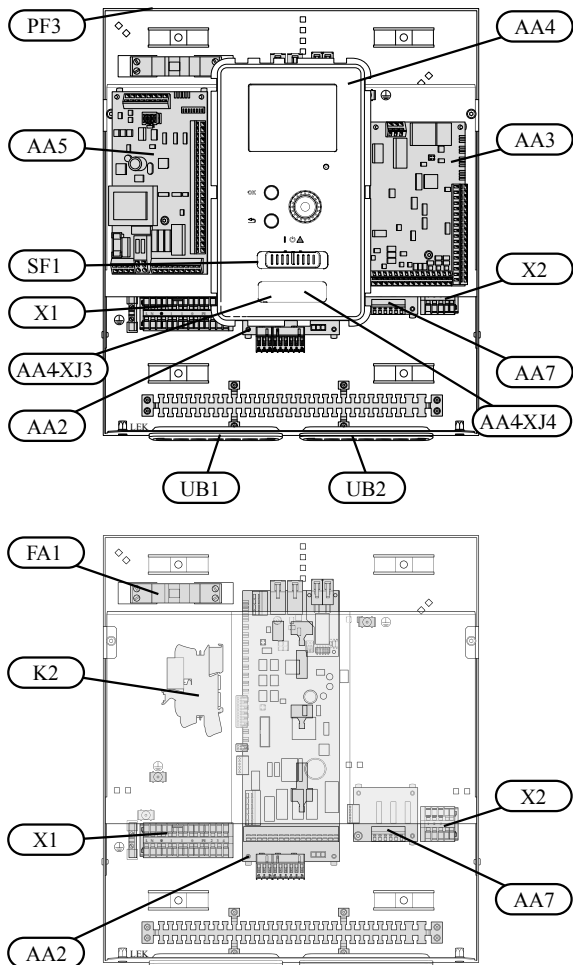

**Accessibility, electrical connection for controller**

The cover of the control module is opened using a Torx 25 screwdriver. Assembly takes place in the reverse order.

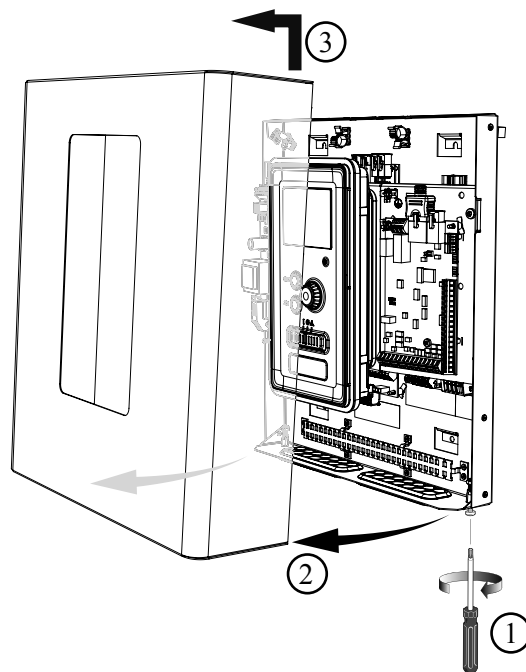

**NOTE**

*The cover to access the base board is opened using a Torx 25 screwdriver*

**Explanation**

- AA2 Base card
- AA3 Input circuit board
- AA4 Display unit
- AA4-XJ3 USB socket
- AA4-XJ4 Service outlet (No function)
- AA5 Accessory card
- AA7 Extra relay circuit board
- FA1 Miniature circuit-breaker
- K2 Emergency mode relay
- X1 Terminal block, incoming electrical supply
- X2 Terminal block, AUX4 - AUX6
- SF1 Switch
- PF3 Serial number plate
- UB1 Cable grommet, incoming supply electricity, power for accessories
- UB2 Cable grommet, signal

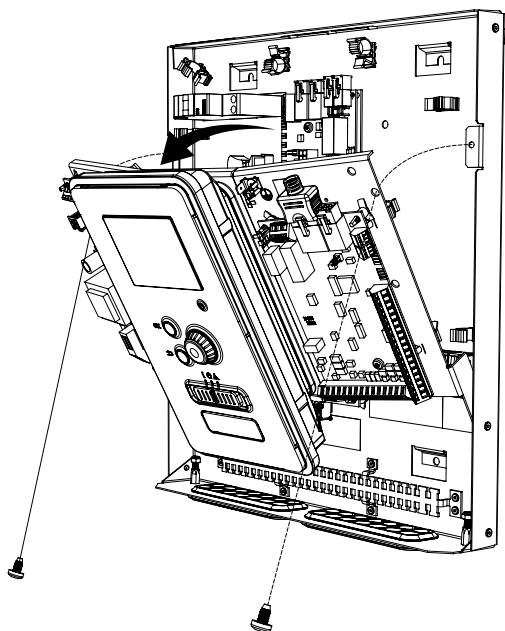

The display may need to be moved for easier access when connecting electrics. This is easily done by following these steps.

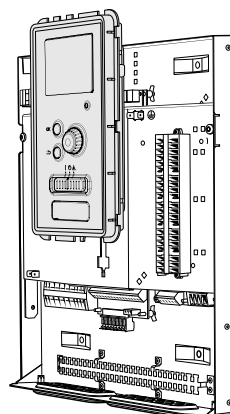
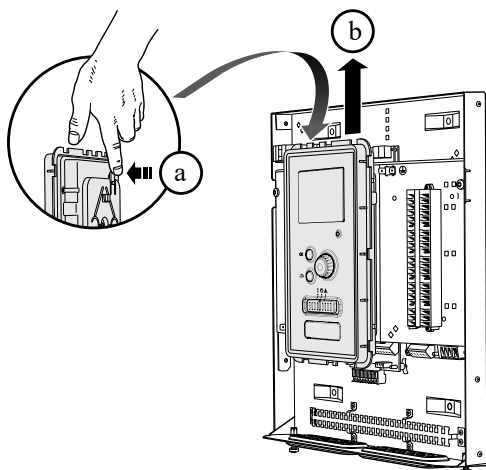

1. Press in the catch on the upper rear side of the display unit towards you (a) and move the display unit upwards (b) so that the mountings unhook from the panel.

4. Secure the display on the panel.

5. When the electrical connection is ready the display must be reinstalled with three mounting points again, otherwise the front cover cannot be installed.

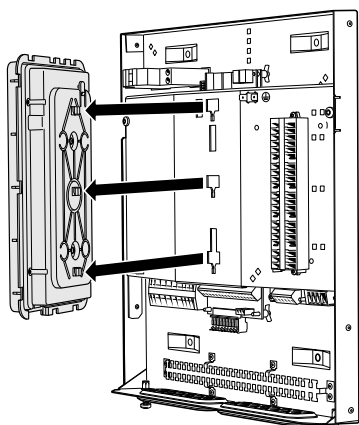

2. Lift the display unit from its mountings.

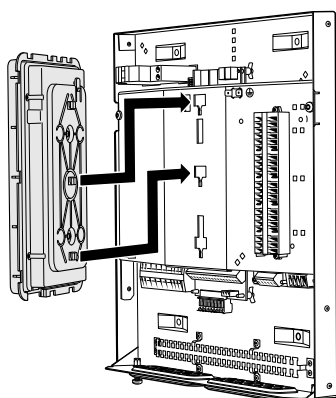

3. Align the two lower mountings on the reverse of the display unit with the two upper holes in the panel as illustrated.

## Outdoor unit

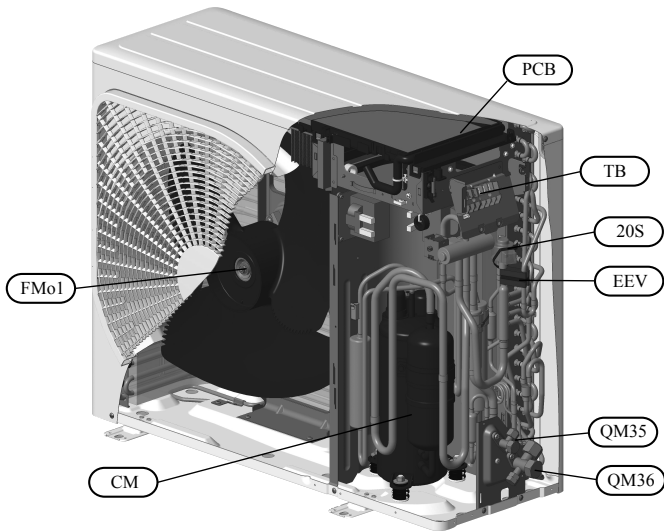

### Component image

FDCW60VNX-W

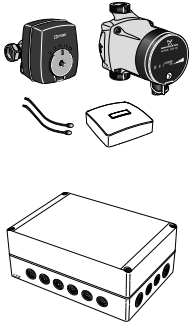
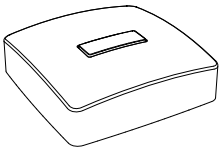
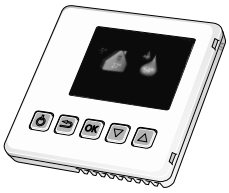
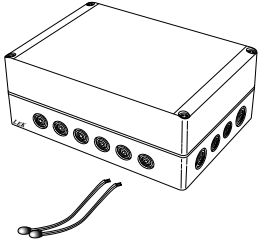

## Accessories

### Accessory parts



Model name	Designation	RC-HY20-W Connection	RC-HY40-W Connection	Part No.
ECS-40M ECS-41M	 <p>Extra climate system</p>	—	✓	MCD291A008/ MCD291A009
RTS40M	 <p>Room sensor</p>	✓	✓ (Included)	MCD291A010
RMU40M	 <p>Room unit</p>	—	✓	MCD291A011
AXC30M	 <p>Accessories</p>	—	✓	MCD291A012
EMK300M	 <p>Energy meter kit</p>	—	✓	MCD291A013
EMK500M		—	✓	MCD291A014

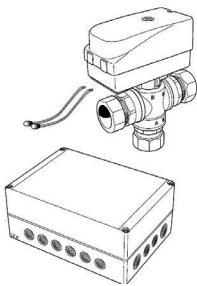
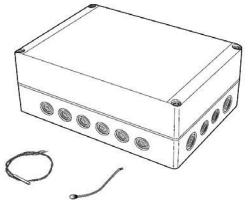
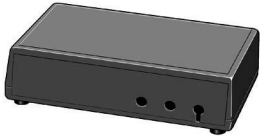
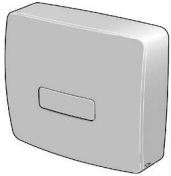

Model name	Designation		RC-HY20-W Connection	RC-HY40-W Connection	Part No.
ELK9M		Immersion heater 9kW	✓	✓	MCD291A015
CPD11-25M/65		Charging pump	✓	✓	MCD291A016
CPD11-25M/75			✓	✓	MCD291A017
VST05M		Hot water control	✓	✓	MCD291A018
VST11M			✓	✓	MCD291A019
VST20M			✓	✓	MCD291A020
VCC05M		Shuttle valve	✓	✓	MCD291A021
VCC11M			✓	✓	MCD291A022

Model name	Designation	RC-HY20-W Connection	RC-HY40-W Connection	Part No.
POOL40M		—	✓	MCD291A030
SOLAR42M		—	✓	MCD291A033
MODBUS40M		—	✓	MCD291A031
EME20M		✓	✓	MCD291A032

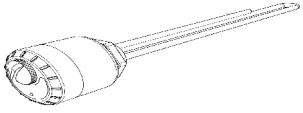
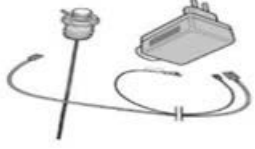
Option parts (for PT tank)

Model name	Designation	Part No.
ME1030M		MCD291A029
AnodeT300		MCD291A024
AnodeT500		MCD291A025
HR10M		MCD291A028

Model name	Designation		Part No.
Anode M300		Magnesium anode	MCD291A026
Anode M500			MCD291A027

**Wind protection** (prepared on site)

At the site where the following conditions are satisfied, wind protection for outdoor unit is required to avoid capacity drop or abnormal stop for protection.

- Natural wind directly blows into outdoor unit.
- Relation between wind speed and outdoor air temperature is in the hatched area at the coldest day.

**< FDCW60VNX-W >**

- Use wind guard in case outdoor unit is installed where ambient temperature drops below  $-10^{\circ}\text{C}$  and natural wind blows into outdoor unit directly.

<For FDCW60VNX-W>

Front wind guard

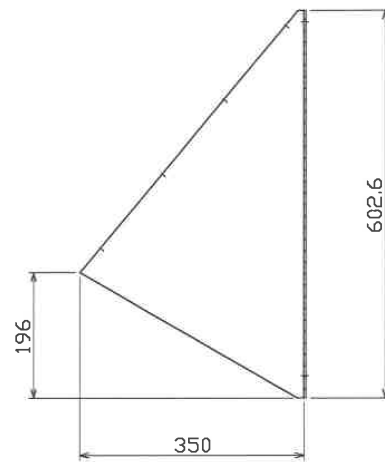
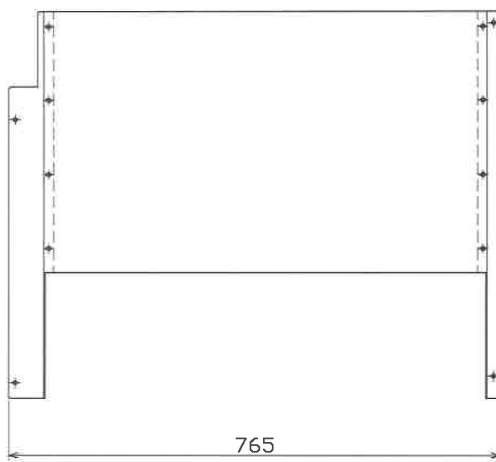

Rear wind guard

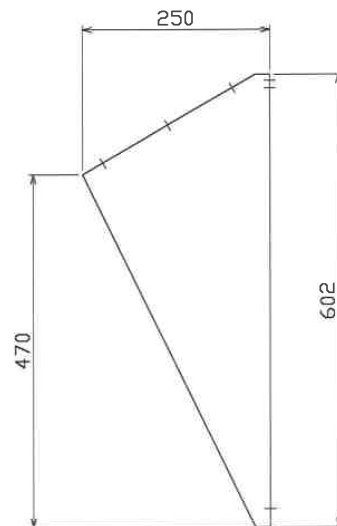
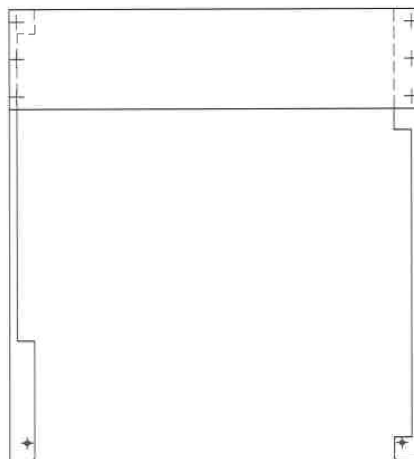
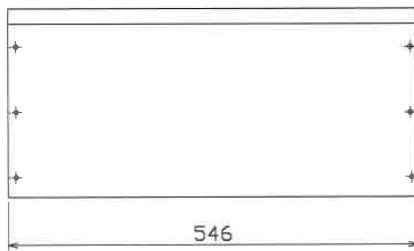

# Piping system

## Indoor unit

### Split box

#### HSB60-W

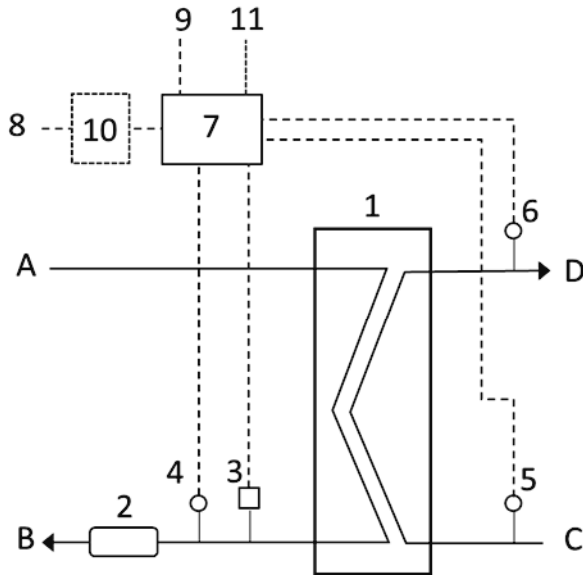

- A: Refrigerant flow
- B: Refrigerant return
- C: Space heating return
- D: Space heating flow

- 1: Condenser
- 2: Filter
- 3: Pressure sensor
- 4: Temperature sensor, refrigerant return
- 5: Temperature sensor, space heating return
- 6: Temperature sensor, space heating flow
- 7: Print control board
- 8: Power source
- 9: Signal cable to outdoor heat pump
- 10: Residual current device (RCD) (option)
- 11: Cable for heat tracing (option)

### (Components location)

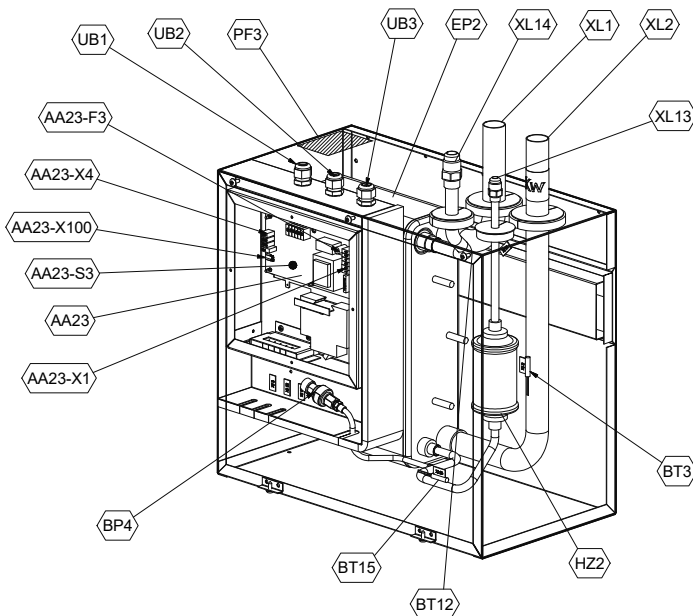

### (Parts name)

- EP2 Heat exchanger
- HZ2 Drying filter
- Electrical components
  - AA23 Communication board
  - AA23-F3 Fuse for external heating cable
  - AA23-S3 DIP switch, addressing of outdoor unit
  - AA23-X1 Terminal block, incoming supply
  - AA23-X4 Terminal block, communication with indoor module / control module
  - AA23-X100 Terminal block, communication outdoor module
- Sensor, thermostats
  - BP4 Pressure sensor, high pressure
  - BT3 Temperature sensor, heating medium, return
  - BT12 Temperature sensor, condenser, supply
  - BT15 Temperature sensor, fluid pipe
- Pipe connections
  - XL1 Connection, heating medium supply
  - XL2 Connection, heating medium return
  - XL53 Connection, liquid cooling medium
  - XL52 Connection, gas cooling medium
- Miscellaneous
  - UB1 Cable gland
  - UB2 Cable gland
  - UB3 Cable gland
  - PF3 Nameplate with serial number

Outside unit

FDCW60VNX-W

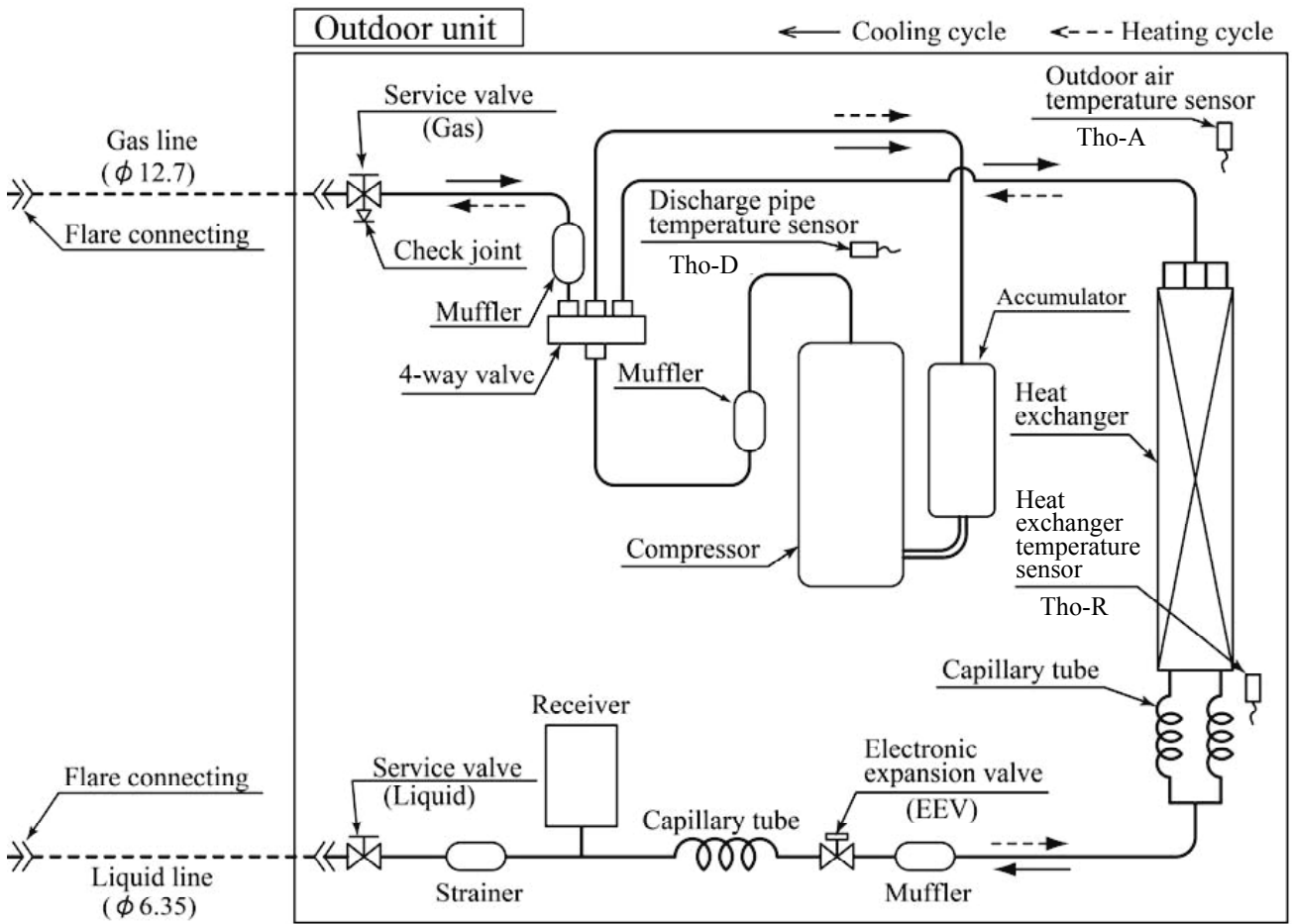

---

# **AIR TO WATER HEAT PUMP**

---



---

**MITSUBISHI HEAVY INDUSTRIES THERMAL SYSTEMS, LTD.**  
2-3, Marunouchi 3-chome, Chiyoda-ku, Tokyo, 100-8332, Japan  
<http://www.mhi-mth.co.jp/en/>

Because of our policy of continuous improvement, we reserve the right to make changes in all specifications without notice.

© Copyright MITSUBISHI HEAVY INDUSTRIES THERMAL SYSTEMS, LTD.