

PRODUCT BULLETIN

Series P78
**Dual Pressure Controls for Refrigeration,
 Air-conditioning and Heatpump Applications**

Introduction

These dual pressure controls are designed for use in a variety of applications involving refrigeration high or low pressure. Models supplied have a "whole range" design, enabling them to be used with refrigerants R22, R134A, R404A and all other non-corrosive refrigerants which are within the operating range of the control. They may also be used for other high or low pressure applications such as air, water etc. Models which can be used with ammonia are included in the program. Also models tested and approved to PED 97/23/EC Cat. IV (supersedes DIN and TUV approval) are included in the program.



P78 Dual Pressure Control for Refrigeration

Description

The P78 series pressure controls may be used for control functions or limit functions, depending on model number. All models are provided with alarm contacts (except P78ALA). All standard models have phosphor bronze bellows and brass pressure connections. Models for use with ammonia are provided with stainless steel bellows and connectors. Devices conforming to PED 97/23/EC Cat. IV (HP models) have the fail-safe function with double bellows. Their IP54 classification means that these pressure controls are suitable for almost all applications.

Feature and Benefits

- | | |
|--|--|
| <input type="checkbox"/> Generous wiring space | Easy wiring and maintenance |
| <input type="checkbox"/> Splash-proof enclosure (IP54) | Can be used for indoor/outdoor applications |
| <input type="checkbox"/> Trip-free manual reset | Override is not possible in the control function |
| <input type="checkbox"/> Patented separate alarm contacts for both low pressure and high pressure cut-out (except P78ALA) | Easy monitoring of the fault location |

Note

The controls are intended to control equipment under normal operating conditions. Where failure or malfunctioning of the controls could lead to an abnormal operating condition that could cause personal injury or damage to the equipment or other property, other devices (limit or safety controls) or systems (alarm or supervisory systems) intended to warn of or protect against failure or malfunctioning of the controls must be incorporated into and maintained as part of the control system.

Note

To facilitate order handling special ordering codes have been added to some commonly used models

Type number matrix

P78LCA	Automatic reset both sides
P78MCA	Automatic reset low side manual reset high side
P78PGA	Manual reset both sides
P78LCW	Automatic reset both sides conform PED 97/23/CE
P78MCB	Automatic reset low side manual reset high side conform PED 97/23/CE
P78MCS	Automatic reset low side manual reset high side conform PED 97/23/CE
P78PGB	Manual reset both sides conform PED 97/23/CE
P78PLM	2 x manual rest HP conform PED 97/23/CE
P78ALA	Dual fan cycling control (2 x SPST close high)

Adjustment

On most models the range scale indicates the high switch point (exception: LP side of P78PGA, P78PGB, here the range scale indicates the low switching point). To obtain low switch point deduct differential value from the high switch point.

Repair and replacement

Repair is not possible. In case of an improperly functioning control, please check with your nearest supplier. When contacting the supplier for a replacement you should state the type/model number of the control. This number can be found on the data plate or cover label.

Contact functions

(see also "Type Number Selection" table)

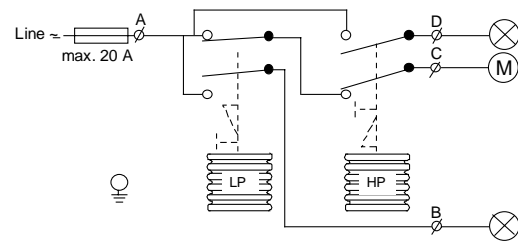

- LP.** A - C opens on pressure decrease
A - B closes simultaneously
- HP.** A - C opens on pressure increase
A - D closes simultaneously

Fig. 1

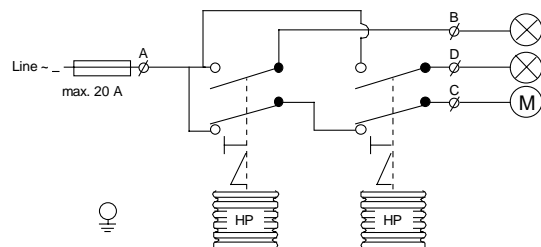

- Left side HP.** A - C opens on pressure increase
A - B closes simultaneously
- Right side HP.** A - C opens on pressure increase
A - D closes simultaneously

Fig. 2

Switching action P78ALA

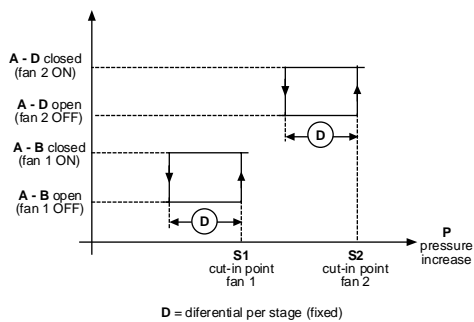

Fig.3a

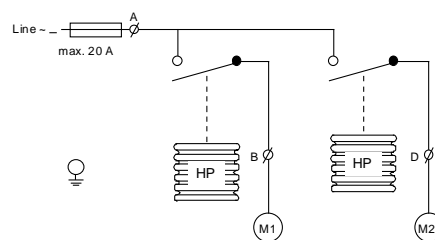

Fig. 3b

Type number selection table

Dual pressure controls for Non-corrosive refrigerants. LP Pmax.: 22bar HP Pmax.:33 bar

Family Code	Pressure Connection				Left Side		Right Side		Contact function (Figure)	Construction
	Style 5			Style 30	Range (bar)	Diff. (bar)	Range (bar)	Diff. (bar)		
	Incl. Pack.	Code***	Bulk-pack	Incl. Pack.						
P78LCA	-9300	P78L	-9320	-9400	-0.5 to 7	0.5 to 3	3 to 30	3 (fixed)	1	LP/HP
P78MCA	-9300	P78M	-9320	-9400	-0.5 to 7	0.5 to 3	3 to 30	Man. res.**	1	

- *** Wholesaler code only for individual pack
 ** Resetable at 3 bar below cut-out point
 * Resetable at 0.5 bar above cut-out point

Dual pressure controls for Ammonia and Non-corrosive refrigerants,
 LP Pmax.: 20 bar HP Pmax.:33 bar

Family Code	Pressure Connection				Left Side		Right Side		Contact function (Figure)	Construction
	Style 15			Incl. Pack.	Range (bar)	Diff. (bar)	Range (bar)	Diff. (bar)		
	Code***	Bulk-pack	****							
P78LCA	-9700		****		-0.5 to 7	0.5 to 3	3 to 30	3 (fixed)	1	LP/HP
P78MCA	-9700		****		-0.5 to 7	0.5 to 3	3 to 30	Man. res.**	1	
P78PGA	-9700		****		-0.5 to 7	Man. res.**	3 to 30	Man. res.**	1	

- **** Can be set-up for quantity orders
 *** Wholesaler code only for individual package
 ** Resetable at 3 bar below cut-out point
 * Resetable at 0.5 bar above cut-out point

Dual pressure Fan cycling controls for Air-cooled condensers (Non-corrosive refrigerants)
 HP Pmax.: 30 bar

Family Code	Pressure Connection				Left Side		Right Side		Contact function (Figure)	Construction
	Style 5			Style 30	Range (bar)	Diff. (bar)	Range (bar)	Diff. (bar)		
	Incl. Pack.	Code***	Bulk-pack	Incl. Pack.						
P78ALA	-9351	P78A	****	-9451	3.5 to 21	1.8 (fixed)	3.5 to 21	1.8 (fixed)	3	HP/HP

- **** Can be set-up for quantity orders
 *** Wholesaler code only for individual package
 Note: 100 kPa = 1 bar ≈ 14.5 psi

Dual pressure controls for Non-corrosive refrigerants,
 (Wächter, Begrenzer, Sicherheitsdruckbegrenzer including lockplate assy)
 (Except P78PGB-*. LP Pmax.: 20 bar HP Pmax.:33 bar

Family Code	Pressure Connection				Left Side		Right Side		Contact function (Figure)	Approved according to PED 97/23EC Cat. IV
	Style 5			Style 28	Range (bar)	Diff. (bar)	Range (bar)	Diff. (bar)		
	Incl. Pack.	Code***	Bulk-pack	Incl. Pack.						
P78LCW	-9300	P78W	-9320	-9800	-0.5 to 7	0.5 to 3	3 to 30	3 (fixed)	1	Yes
P78MCB	-9300	P78B	-9320	-9800	-0.5 to 7	0.5 to 3	3 to 30	Man. res.**	1	Yes
P78MCS	-9300	P78S	-9320	-9800	-0.5 to 7	0.5 to 3	3 to 30	Man. res.**	1	Yes
P78PGB	-9300	P78P	****	-9800	-0.5 to 7	Man. res.*	3 to 30	Man. res.**	1	Yes
P78PLM	-9350	P78BS	****	-9850	3 to 30	Man. res.**	3 to 30	Man. res.**	2	Yes

- **** Can be set up for quantity orders
 *** Wholesaler code only for individual pack
 ** Resetable at 3.5 bar below cut-out point
 * Resetable at 0.5 bar above cut-out point

Pressure connections

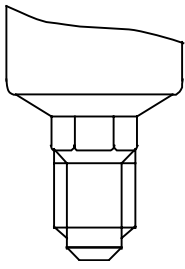

**Fig. 4
Style 5**
Male connector
7/16"-20 UNF for 1/4"
6 mm flare nut.

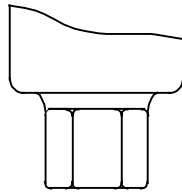

**Fig. 5
Style 15**
Female connector
1/4"-18 NPT

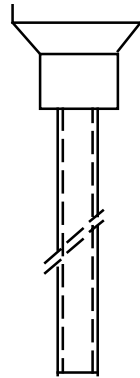

**Fig. 6
Style 28**
Braze connection
6 mm ODM

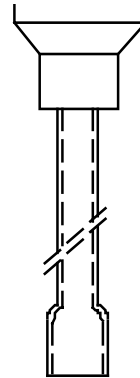

**Fig. 7
Style 30**
Braze connection
1/4" ODF

Accessories (optional)

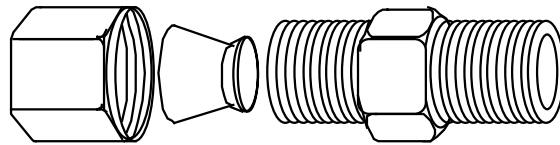

Fig. 8

Description	Application	Order number
Fits into style 15 pressure connectors	For 6 mm copper or steel tubing	CNR003N001R
	For 8 mm copper or steel tubing	CNR003N002R

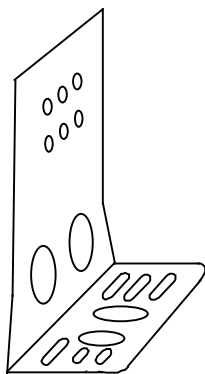

Fig. 9
Mounting bracket
Order number **271-51L**

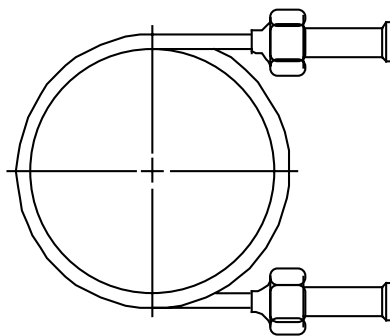

Fig. 10
90 cm Capillary with (2) flare
nuts (1/4" SAE)
Order number **SEC002N600**

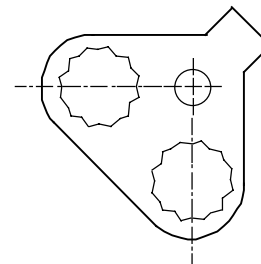
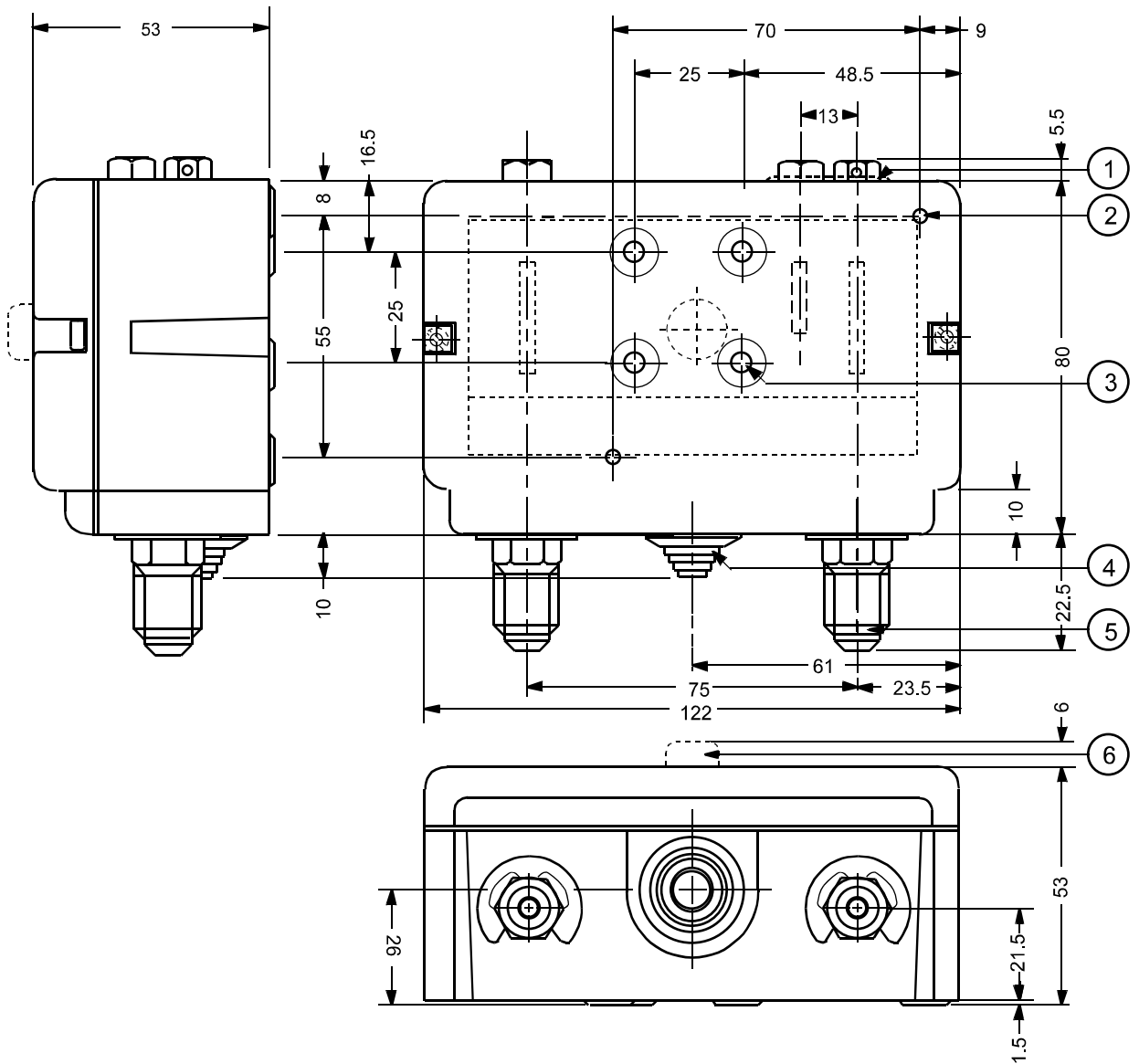

Fig. 11
Locking kit
Order number **KIT023N600**

Dimensions (mm)



1. lock plate (if applied)
2. two mounting holes Ø 4.5 mm (knock out)
3. four mounting holes Ø M4 (back side)
4. cable inlet grommet (cable range Ø 5 to Ø 13 mm)
5. power element:
Style 5: 7/16"-20 UNF male (shown)
Style 15: 1/4"-18 NPT female
6. reset button

Fig. 12

Dimensions (mm)

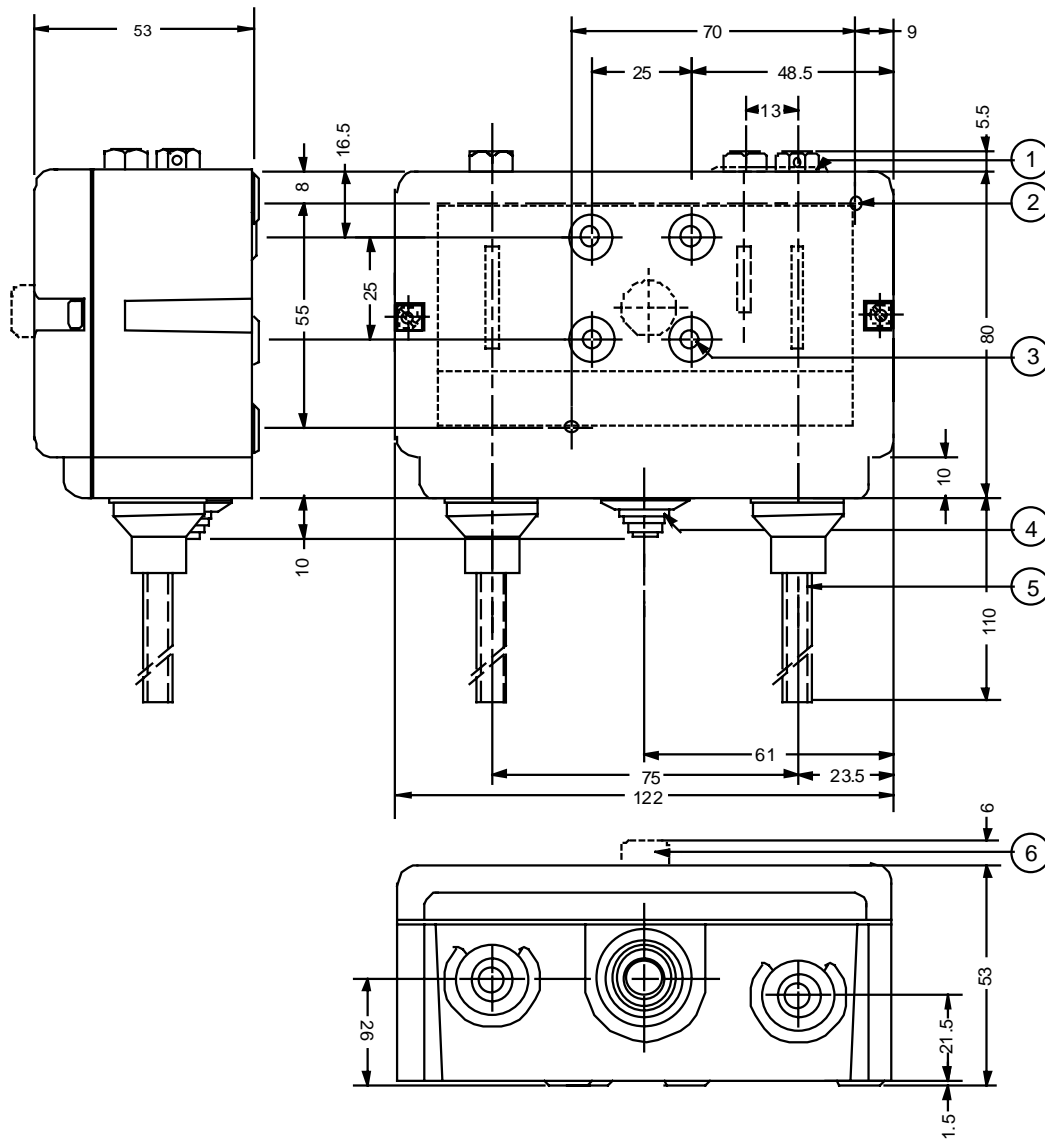

1. lock plate (if applied)
2. two mounting holes \varnothing 4.5 mm (knock out)
3. four mounting holes \varnothing M4 (back side)
4. cable inlet grommet (cable range \varnothing 5 to \varnothing 13 mm)
5. power element:
 Style 28: Braze connection 6 mm ODM (shown)
 Style 30: Braze connection 1/4" ODF
6. reset button

Fig. 13

Notes

Technical Specifications

Pressure connections	Style 5, 15, 28, 30 (see drawings)		
Operating ranges and diff.	See type number selection		
Adjustments	See type number selection		
Ambient temp. limit	-50 to +55 °C (+70 °C max. duration two hours) -20 to +55 °C for PED approved models		
Electrical ratings	400 Vac	contact A-C	16(10) A
		contact A-B	8(5) A
		contact A-D	8(5) A
	220 Vdc 12 W (pilot duty only)		
Pulsation plug	Fitted into all HP bellows		
Locking plate and screw	To lock and seal range and/or differential screw. Standard on types P78LCW, MCB, MCS, PGB and PLM. Optional on all other types (quantity orders only)		
Protection Class	IP54		
Material	Case and cover	Weatherproof aluminium (die-cast)	
	Contact unit	Large copper-backed silver cadmium contacts (AgCdO) on conductor leaves	
Accessories (see pag. 4)	Mounting bracket Compression coupling 90 cm capillary with two flare nuts		
Shipping weight	ind. pack	0.8 kg	
	-93xx	}	Ind. overpack 30 pcs. (24.5 kg)
	-97xx		Bulk pack 24 pcs. (19.5 kg)
	-94xx	}	Ind. overpack 13 pcs. (11 kg)
	-98xx		

The performance specifications are nominal and conform to acceptable industry standards. For applications at conditions beyond these specifications, consult the local Johnson Controls office or representative. Johnson Controls shall not be liable for damages resulting from misapplication or misuse of its products.

**JOHNSON
CONTROLS**

Johnson Controls International, Inc.

Headquarters: Milwaukee, Wisconsin, USA
Branch Offices: Principal Cities World-wide

This document is subject to change

www.johnsoncontrols.com
Printed in Europe